

BCL348i
Bar code reader



Sales and Service

Germany

Sales Region North

Phone 07021/573-306
Tel. Int. + 34 93 4097900
Fax 07021/9850950

Postal code areas
20000-38999
40000-65999
97000-97999

Sales Region South

Phone 07021/573-307
Tel. Int. + 34 93 94935820
Fax 07021/9850911

Postal code areas
66000-96999

Sales Region East

Phone 035027/629-106
Tel. Int. + 49 35027/629-107
Fax 035027/629-107

Postal code areas
01000-19999
39000-39999
98000-99999

Worldwide

AR (Argentina)

Condelectric S.A.
Tel. Int. + 54 1148 361053
Fax Int. + 54 1148 361053

AT (Austria)

Schmachtl GmbH
Tel. Int. + 43 732 7646-0
Fax Int. + 43 732 7646-785

AU + NZ (Australia + New Zealand)

Balluff/Leuze Pty. Ltd.
Tel. Int. + 61 3 9720 4100
Fax Int. + 61 3 9738 2677

BE (Belgium)

Leuze electronic nv/sa
Tel. Int. + 32 2253 16-00
Fax Int. + 32 2253 15-36

BG (Bulgaria)

ATICS
Tel. Int. + 359 2 847 6244
Fax Int. + 359 2 847 6244

BR (Brazil)

Leuze electronic Ltda.
Tel. Int. + 55 11 5180-6130
Fax Int. + 55 11 5180-6141

CH (Switzerland)

Leuze electronic AG
Tel. Int. + 41 41 784 5656
Fax Int. + 41 41 784 5657

CL (Chile)

Imp. Tec. Vignola S.A.I.C.
Tel. Int. + 56 3235 11-11
Fax Int. + 56 3235 11-28

CN (China)

Leuze electronic Trading
(Shenzhen) Co. Ltd.
Tel. Int. + 86 755 862 64909
Fax Int. + 86 755 862 64901

CO (Colombia)

Componentes Electronicas Ltda.
Tel. Int. + 57 4 3511049
Fax Int. + 57 4 3511019

CZ (Czech Republic)

Schmachtl CZ s.r.o.
Tel. Int. + 420 244 0015-00
Fax Int. + 420 244 9107-00

DK (Denmark)

Leuze electronic Scandinavia ApS
Tel. Int. + 45 48 173200

ES (Spain)

Leuze electronic S.A.
Tel. Int. + 34 93 4097900
Fax Int. + 34 93 94935820

FI (Finland)

SKS-automatio Oy
Tel. Int. + 358 20 764-61
Fax Int. + 358 20 764-6820

FR (France)

Leuze electronic Sarl.
Tel. Int. + 33 160 0512-20
Fax Int. + 33 160 0503-65

GB (United Kingdom)

Leuze electronic Ltd.
Tel. Int. + 44 14 8040 85-00
Fax Int. + 44 14 8040 38-08

GR (Greece)

UTECO A.B.E.E.
Tel. Int. + 30 211 1206 900
Fax Int. + 30 211 1206 999

HK (Hong Kong)

Sensortech Company
Tel. Int. + 852 26510188
Fax Int. + 852 26510388

HR (Croatia)

Tipteh Zagreb d.o.o.
Tel. Int. + 385 1 381 6574
Fax Int. + 385 1 381 6577

HU (Hungary)

Kvaik Automatika Kft.
Tel. Int. + 36 1 272 2242
Fax Int. + 36 1 272 2244

ID (Indonesia)

P.T. Yabestindo Mitra Utama
Tel. Int. + 62 21 92861859
Fax Int. + 62 21 6451044

IL (Israel)

Galoz electronics Ltd.
Tel. Int. + 972 3 9023456
Fax Int. + 972 3 9021990

IN (India)

M + V Marketing Sales Pvt Ltd.
Tel. Int. + 91 124 4121623
Fax Int. + 91 124 434223

IT (Italy)

Leuze electronic S.r.l.
Tel. Int. + 39 02 26 1106-43
Fax Int. + 39 02 26 1106-40

JP (Japan)

C. Illies & Co., Ltd.
Tel. Int. + 81 3 3443 4143
Fax Int. + 81 3 3443 4118

KE (Kenia)

Profa-Tech Ltd.
Tel. Int. + 254 20 828095/6
Fax Int. + 254 20 828129

KR (South Korea)

Leuze electronic Co., Ltd.
Tel. Int. + 82 31 3828228
Fax Int. + 82 31 3828252

MK (Macedonia)

Tipteh d.o.o. Skopje
Tel. Int. + 389 70 399 474
Fax Int. + 389 23 174 197

MX (Mexico)

Movitren S.A.
Tel. Int. + 52 81 8371 8616
Fax Int. + 52 81 8371 8588

MY (Malaysia)

Ingermark (M) SDN.BHD
Tel. Int. + 60 360 3427-88
Fax Int. + 60 360 3421-88

NG (Nigeria)

SABROW HI-TECH E. & A. LTD.
Tel. Int. + 234 80333 86366
Fax Int. + 234 80333 84463518

NL (Netherlands)

Leuze electronic BV
Tel. Int. + 31 418 65 35-44
Fax Int. + 31 418 65 38-08

NO (Norway)

Elteco A/S
Tel. Int. + 47 35 56 20-70
Fax Int. + 47 35 56 20-99

PL (Poland)

Balluff Sp. z o. o.
Tel. Int. + 48 71 338 49 29
Fax Int. + 48 71 338 49 30

PT (Portugal)

LA2P, Lda.
Tel. Int. + 351 21 4 447070
Fax Int. + 351 21 4 447075

RO (Romania)

O BOYLE s.r.l.
Tel. Int. + 40 2 56201346
Fax Int. + 40 2 56221036

RS (Republic of Serbia)

Tipteh d.o.o. Beograd
Tel. Int. + 381 11 3131 057
Fax Int. + 381 11 3018 326

RU (Russian Federation)

ALL IMPEX 2001
Tel. Int. + 7 495 9213012
Fax Int. + 7 495 6462092

SE (Sweden)

Leuze electronic Scandinavia ApS
Tel. Int. +46 380-490951

SG + PH (Singapore + Philippines)

Balluff Asia Pte Ltd
Tel. Int. + 65 6252 43-84
Fax Int. + 65 6252 90-60

SI (Slovenia)

Tipteh d.o.o.
Tel. Int. + 386 1200 51-50
Fax Int. + 386 1200 51-51

SK (Slovakia)

Schmachtl SK s.r.o.
Tel. Int. + 421 2 58275600
Fax Int. + 421 2 58275601

TH (Thailand)

Industrial Electrical Co. Ltd.
Tel. Int. + 66 2 642 6700
Fax Int. + 66 2 642 4250

TR (Turkey)

Leuze electronic San ve Tic.Ltd.Siti.
Tel. Int. + 90 216 456 6704
Fax Int. + 90 216 456 3650

TW (Taiwan)

Great Colvue Technology Co., Ltd.
Tel. Int. + 886 2 2983 80-77
Fax Int. + 886 2 2985 33-73

UA (Ukraine)

SV Altera OOO
Tel. Int. + 38 044 4961888
Fax Int. + 38 044 4961818

US + CA (United States + Canada)

Leuze electronic, Inc.
Tel. Int. + 1 248 486-4466
Fax Int. + 1 248 486-6699

ZA (South Africa)

Countapulse Controls (PTY).Ltd.
Tel. Int. + 27 116 1575-56
Fax Int. + 27 116 1575-13

1	General information.....	11
1.1	Explanation of symbols.....	11
1.2	Declaration of conformity	11
2	Safety notices	12
2.1	General safety notices.....	12
2.2	Safety standards	12
2.3	Approved purpose	12
2.4	Working safely	13
3	Fast commissioning / operating principle.....	15
3.1	Mounting the BCL 348 <i>i</i>	15
3.2	Device arrangement and selection of the mounting location.....	15
3.3	Electrical connection BCL 348 <i>i</i>	16
3.4	Preparatory PROFINET-IO settings	18
3.4.1	Commissioning the BCL 348 <i>i</i> on the PROFINET-IO	18
3.4.2	Preparing the control system.....	19
3.4.3	Installing the GSD file	19
3.4.4	Configuration	19
3.4.5	Transfer of the configuration to the IO Controller	20
3.4.6	Configuration of the device name - device naming.....	21
3.4.7	Check device name	22
3.5	Further settings.....	22
3.6	Starting the device.....	23
3.7	Bar code reading.....	25
4	Device description	26
4.1	About the bar code readers of the BCL 300 <i>i</i> series.....	26
4.2	Characteristics of the bar code readers of the BCL 300 <i>i</i> series.....	27
4.3	Device construction.....	29
4.4	Reading techniques.....	32
4.4.1	Line scanner (single line).....	32
4.4.2	Line scanner with oscillating mirror.....	33
4.4.3	Raster scanner (Raster Line).....	34
4.5	Fieldbus systems	35
4.5.1	PROFINET-IO.....	35
4.5.2	PROFINET-IO – star topology	37
4.5.3	PROFINET-IO – linear topology	38
4.6	Heater	38
4.7	External parameter memory in the MS 348 / MK 348	38

4.8	autoReflAct	39
4.9	Reference codes	39
4.10	autoConfig	40
5	Specifications	41
5.1	General specifications of the bar code readers	41
5.1.1	Line scanner / raster scanner.....	41
5.1.2	Oscillating-mirror scanner	43
5.1.3	Line scanner / raster scanner with deflection mirror.....	43
5.2	Heating models of the bar code readers	44
5.2.1	Line scanner / raster scanner with heater	45
5.2.2	Oscillating-mirror scanner with heating	45
5.2.3	Line scanner / raster scanner with deflection mirror and heating.....	46
5.3	Dimensioned drawings	47
5.3.1	Dimensioned drawing of complete overview of the BCL 348 <i>i</i> with MS 3xx / MK 3xx.....	47
5.3.2	Dimensioned drawing of line scanner with / without heating.....	48
5.3.3	Dimensioned drawing of deflection mirror scanner with / without heating.....	49
5.3.4	Dimensioned drawing of oscillating-mirror scanner with / without heating	50
5.3.5	Dimensioned drawing of MS 3xx hood with integrated connectors / MK 3xx terminal hood.....	51
5.4	Reading field curves / optical data	52
5.4.1	Bar code characteristics	52
5.4.2	Raster scanner	53
5.5	Reading field curves	54
5.5.1	High Density (N) - optics: BCL 348 <i>i</i> S/R1 N 102 (H).....	55
5.5.2	High Density (N) - optics: BCL 348 <i>i</i> S/R1 N 100 (H).....	55
5.5.3	High Density (N) - optics: BCL 348 <i>i</i> ON 100 (H).....	56
5.5.4	Medium Density (M) - optics: BCL 348 <i>i</i> S/R1 M 102 (H).....	57
5.5.5	Medium Density (M) - optics: BCL 348 <i>i</i> S/R1 M 100 (H).....	57
5.5.6	Medium Density (M) - optics: BCL 348 <i>i</i> OM 100 (H).....	58
5.5.7	Low Density (F) - optics: BCL 348 <i>i</i> S/R1 F 102 (H)	59
5.5.8	Low Density (F) - optics: BCL 348 <i>i</i> S/R1 F 100 (H)	59
5.5.9	Low Density (F) - optics: BCL 348 <i>i</i> OF 100 (H).....	60
5.5.10	Ultra Low Density (L) - optics: BCL 348 <i>i</i> S/R1 L 102 (H)	61
5.5.11	Ultra Low Density (L) - optics: BCL 348 <i>i</i> S/R1 L 100 (H)	61
5.5.12	Ultra Low Density (L) - optics: BCL 348 <i>i</i> OL 100 (H)	62
6	Installation and mounting	63
6.1	Storage, transportation	63
6.2	Mounting the BCL 348<i>i</i>	64
6.2.1	Fastening with M4 x 5 screws	64
6.2.2	BT 56 mounting device	65
6.2.3	BT 59 mounting device	67

6.3	Device arrangement.....	68
6.3.1	Selecting a mounting location	68
6.3.2	Avoiding total reflection – Line scanner	69
6.3.3	Avoiding total reflection – deflection mirror scanner	69
6.3.4	Avoiding total reflection – oscillating-mirror scanner	70
6.3.5	Mounting location.....	70
6.3.6	Devices with integrated heating.....	71
6.3.7	Possible reading angles between BCL 348 <i>i</i> and bar code	71
6.4	Cleaning.....	72
7	Electrical connection.....	73
7.1	Safety notices for the electrical connection.....	74
7.2	Electrical connection BCL 348<i>i</i>	75
7.2.1	MS 348 hood with 3 integrated M12 connectors	75
7.2.2	MK 348 terminal hood with spring-loaded terminals.....	76
7.3	Detailed description of the connections.....	78
7.3.1	PWR / SW IN/OUT - Voltage supply and switching input/outputs 1 and 2	78
7.3.2	SERVICE – USB interface (Mini-B type)	81
7.3.3	HOST / BUS IN for BCL 348 <i>i</i>	82
7.3.4	BUS OUT for the BCL 348 <i>i</i>	83
7.4	PROFINET-IO topologies.....	84
7.4.1	PROFINET-IO wiring	85
7.5	Cable lengths and shielding	86
8	Display elements and display.....	87
8.1	LED indicators BCL 348<i>i</i>	87
8.2	MS 348/MK 348 LED indicators.....	89
8.3	Display BCL 348<i>i</i>.....	90
9	Leuze webConfig tool.....	92
9.1	Connecting the SERVICE USB interface.....	92
9.2	Installing the required software.....	93
9.2.1	System requirements.....	93
9.2.2	Installing the USB driver	93
9.3	Starting the webConfig tool	94
9.4	Short description of the webConfig tool.....	95
9.4.1	Module overview in the Configuration menu.....	95
10	Commissioning and configuration.....	97
10.1	General information on the PROFINET-IO implementation of the BCL 348<i>i</i>.....	97
10.1.1	PROFINET-IO communication profile.....	97
10.1.2	Conformance Classes	98

10.2	Measures to be performed prior to the initial commissioning	98
10.3	Starting the device.....	100
10.4	Configuration steps for a Siemens Simatic S7 control	100
10.4.1	Step 1 – Preparing the control system (S7 PLC)	100
10.4.2	Step 2 – Installation of the GSD file	100
10.4.3	Step 3 – Hardware configuration of the S7 PLC: Configuration.....	102
10.4.4	Step 4 – Transfer of the configuration to the IO Controller (S7 PLC).....	102
10.4.5	Step 5 – Configuration of the device name - naming the device.....	103
10.4.6	Step 6 – Check device names	104
10.4.7	Manually setting the IP address	105
10.4.8	Ethernet host communication.....	106
10.4.9	TCP/IP.....	106
10.4.10	UDP.....	107
10.5	Commissioning via the PROFINET-IO	108
10.5.1	General information.....	108
10.5.2	Permanently defined parameters / device parameters.....	109
10.6	Overview of the project modules	113
10.7	Decoder modules.....	116
10.7.1	Modules 1-4 – Code table extensions 1 to 4.....	116
10.7.2	Module 5 – Code type features (sympology).....	118
10.7.3	Module 7 – Code fragment technology	119
10.8	Control modules	120
10.8.1	Module 10 – Activations	120
10.8.2	Module 11 – Reading gate control	122
10.8.3	Module 12 – Multi-label	124
10.8.4	Module 13 – Fragmented read result	125
10.8.5	Module 14 – Interlinked read result.....	126
10.9	Result Format.....	127
10.9.1	Module 20 – Decoder state	127
10.9.2	Modules 21-27 – Decoding result	129
10.9.3	Module 30 – Data formatting	131
10.9.4	Module 31 – Reading gate number.....	132
10.9.5	Module 32 – Reading gate time	133
10.9.6	Module 33 – Code position	133
10.9.7	Module 34 – Reading reliability (equal scans).....	134
10.9.8	Module 35 – Bar code length	134
10.9.9	Module 36 – Scans with information	135
10.9.10	Module 37 – Decoding quality	135
10.9.11	Module 38 – Code direction	136
10.9.12	Module 39 – Number of digits	136
10.9.13	Module 40 – Code type (sympology).....	137
10.9.14	Module 41 – Code position in the swivel range.....	138
10.10	Data Processing.....	139
10.10.1	Module 50 – Characteristics filter.....	139
10.10.2	Module 51 – Data filtering	141

10.11	Identifier	142
10.11.1	Module 52 – Segmentation according to the EAN process	142
10.11.2	Module 53 – Segmentation via fixed positions	143
10.11.3	Module 54 – Segmentation according to identifier and separator	145
10.11.4	Module 55 – String handling parameters	148
10.12	Device Functions	149
10.12.1	Module 60 – Device status	149
10.12.2	Module 61 – Laser control	150
10.12.3	Module 63 – Alignment	151
10.12.4	Module 64 – Oscillating mirror	152
10.13	Switching inputs / outputs SWIO 1 ... 2	153
10.13.1	Parameters for operating as an output	153
10.13.2	Parameters for operating as an input	155
10.13.3	Switch-on and switch-off functions for operation as an output	156
10.13.4	Input functions for operation as an input	157
10.13.5	Module 70 – Switching input/output SWIO1	157
10.13.6	Module 71 – Switching input/output SWIO2	159
10.13.7	Module 74 – SWIO status and control	161
10.14	Data output	163
10.14.1	Module 80 – Sorting	163
10.15	Reference code comparison	164
10.15.1	Module 81 – Reference code comparator 1	164
10.15.2	Module 82 – Reference code comparator 2	166
10.15.3	Module 83 – Reference code comparison pattern 1	168
10.15.4	Module 84 – Reference code comparison pattern 2	169
10.16	Special Functions	171
10.16.1	Module 90 – Status and control	171
10.16.2	Module 91 – AutoReflAct (automatic reflector activation)	172
10.16.3	Module 92 – AutoControl	173
10.17	Example configuration: Indirect activation via the PLC	174
10.17.1	Task	174
10.17.2	Procedure	174
10.18	Sample configuration: Direct activation via the switching input	176
10.18.1	Task	176
10.18.2	Procedure	176
10.19	Sample configuration: Indirect activation via the switching input	178
10.19.1	Task	178
10.19.2	Procedure	178
11	Online commands	180
11.1	Overview of commands and parameters	180
11.1.1	General 'online' commands	181
11.1.2	'Online' commands for system control	188
11.1.3	'Online' commands for configuration of switching inputs/outputs	189
11.1.4	'Online' commands for the parameter set operations	192

12	Diagnostics and troubleshooting	199
12.1	General causes of errors.....	199
12.2	Interface errors.....	200
13	Type overview and accessories	201
13.1	Part number code	201
13.2	Type overview BCL 348 <i>i</i>	202
13.3	Connection hood accessories.....	203
13.4	Accessory connectors	203
13.5	Accessory USB cable	203
13.6	Accessory mounting device	203
13.7	Reflector accessories for autoReflAct.....	203
13.8	Accessory ready-made cables for voltage supply	204
13.8.1	Contact assignment of PWR connection cable	204
13.8.2	Specifications of the cables for voltage supply.....	204
13.8.3	Order codes of the cables for voltage supply	204
13.9	Accessory ready-made cables for bus connection	204
13.9.1	General information.....	204
13.9.2	Contact assignments M12 PROFINET-IO connection cable KB ET.....	205
13.9.3	Specifications M12 PROFINET-IO connection cable KB ET.....	205
13.9.4	Order codes M12 PROFINET-IO connection cable KB ET.....	206
14	Maintenance	207
14.1	General maintenance information.....	207
14.2	Repairs, servicing	207
14.3	Disassembling, packing, disposing	207
15	Appendix	208
15.1	Declaration of Conformity.....	208
15.2	ASCII character set	210
15.3	Bar code samples	214
15.3.1	Module 0.3	214
15.3.2	Module 0.5	215

Figure 2.1:	Attachment of the stick-on labels with warning notices at the BCL 348 <i>i</i>	14
Figure 3.1:	BCL 348 <i>i</i> - MS 348 hood with integrated M12 connectors	16
Figure 3.2:	BCL 348 <i>i</i> - MK 348 terminal hood with spring-loaded terminals.....	17
Figure 3.3:	Cable fabrication for MK 308 terminal hood.....	17
Figure 3.4:	Assignment of the device names to IP addresses	19
Figure 3.5:	Assigning the device names to the configured IO devices.....	21
Figure 3.6:	MAC address - IP address -individual device name	22
Figure 4.1:	Line scanner, line scanner with deflection mirror and oscillating-mirror scanner.....	26
Figure 4.2:	Possible bar code orientation.....	28
Figure 4.3:	BCL 348 <i>i</i> device construction - line scanner.....	29
Figure 4.4:	BCL 348 <i>i</i> device construction -line scanner with deflection mirror.....	29
Figure 4.5:	BCL 348 <i>i</i> device construction - oscillating-mirror scanner	30
Figure 4.6:	Device construction MS 348 hood with integrated connectors	31
Figure 4.7:	Device construction MK 348 hood with integrated connectors	31
Figure 4.8:	Deflection principle for the line scanner	32
Figure 4.9:	Deflection principle for the line scanner with oscillating mirror add-on	33
Figure 4.10:	Deflection principle for the raster scanner.....	34
Table 4.1:	Base record I&M0	36
Figure 4.11:	PROFINET-IO in a star topology.....	37
Figure 4.12:	PROFINET-IO in a linear topology.....	38
Figure 4.13:	Reflector arrangement for autoReflAct.....	39
Table 5.1:	Specifications of the BCL 348 <i>i</i> oscillating-mirror scanners without heating.....	43
Table 5.2:	Specifications of the BCL 348 <i>i</i> deflection-mirror scanners without heating	43
Table 5.3:	Specifications of the BCL 348 <i>i</i> line/raster scanners with heating	45
Table 5.4:	Specifications of the BCL 348 <i>i</i> oscillating-mirror scanners with heating.....	45
Table 5.5:	Specifications of the BCL 348 <i>i</i> deflection mirror scanners with heating	46
Figure 5.1:	Dimensioned drawing of complete overview of the BCL 348 <i>i</i> with MS 3xx / MK 3xx	47
Figure 5.2:	Dimensioned drawing BCL 348 <i>i</i> line scanner S...102	48
Figure 5.3:	Dimensioned drawing BCL 348 <i>i</i> deflection mirror scanner S...100	49
Figure 5.4:	Dimensioned drawing BCL 348 <i>i</i> oscillating mirror scanner O...100	50
Figure 5.5:	Dimensioned drawing of MS 3xx hood with integrated connectors / MK 3xx terminal hood.....	51
Figure 5.6:	The most important characteristics of a bar code	52
Table 5.6:	Raster line cover as a function of the distance	53
Figure 5.7:	Zero position of the reading distance.....	54
Table 5.7:	Reading conditions	54
Figure 5.8:	"High Density" reading field curve for line scanner without deflection mirror	55
Figure 5.9:	"High Density" reading field curve for line scanner with deflection mirror	55
Figure 5.10:	"High Density" reading field curve for oscillating-mirror scanners.....	56
Figure 5.11:	Lateral "High Density" reading field curve for oscillating-mirror scanners.....	56
Figure 5.12:	"Medium Density" reading field curve for line scanner without deflection mirror.....	57
Figure 5.13:	"Medium Density" reading field curve for line scanner with deflection mirror.....	57
Figure 5.14:	"Medium Density" reading field curve for oscillating-mirror scanners	58
Figure 5.15:	Lateral "Medium Density" reading field curve for oscillating-mirror scanners	58

Figure 5.16:	"Low Density" reading field curve for line scanner without deflection mirror	59
Figure 5.17:	"Low Density" reading field curve for line scanner with deflection mirror	59
Figure 5.18:	"Low Density" reading field curve for oscillating-mirror scanners	60
Figure 5.19:	Lateral "Low Density" reading field curve for oscillating-mirror scanners	60
Figure 5.20:	"Ultra Low Density" reading field curve for line scanner without deflection mirror	61
Figure 5.21:	"Ultra Low Density" reading field curve for line scanner with deflection mirror	61
Figure 5.22:	"Ultra Low Density" reading field curve for oscillating-mirror scanners	62
Figure 5.23:	Lateral "Ultra Low Density" reading field curve for oscillating-mirror scanners	62
Figure 6.1:	Device name plate BCL 348 <i>i</i>	63
Figure 6.2:	Fastening options using M4x5 threaded holes	64
Figure 6.3:	BT 56 mounting device	65
Figure 6.4:	Mounting example of BCL 348 <i>i</i> with BT 56	66
Figure 6.5:	BT 59 mounting device	67
Figure 6.6:	Total reflection – line scanner	69
Figure 6.7:	Total reflection – line scanner	69
Figure 6.8:	Total reflection – BCL 348 <i>i</i> with oscillating mirror	70
Figure 6.9:	Reading angle for the line scanner	71
Figure 7.1:	Location of the electrical connections	73
Figure 7.2:	BCL 348 <i>i</i> - MS 348 hood with integrated M12 connectors	75
Figure 7.3:	BCL 348 <i>i</i> - MK 348 terminal hood with spring-loaded terminals	76
Figure 7.4:	Cable fabrication for MK 348 terminal hood	77
Table 7.1:	Pin assignment PWR / SW IN/OUT	78
Figure 7.1:	Switching input connection diagram SWIO_1 and SWIO_2	79
Figure 7.2:	Switching output connection diagram SWIO_1 / SWIO_2	80
Table 7.2:	Pin assignment SERVICE – Mini-B type USB interface	81
Table 7.3:	Pin assignment HOST / BUS IN BCL 348 <i>i</i>	82
Figure 7.3:	HOST / BUS IN cable assignments on RJ-45	82
Table 7.4:	Pin assignment BUS OUT BCL 348 <i>i</i>	83
Figure 7.4:	PROFINET-IO in a star topology	84
Figure 7.5:	PROFINET-IO in a line topology	85
Table 7.5:	Cable lengths and shielding	86
Figure 8.1:	BCL 348 <i>i</i> - LED indicators	87
Figure 8.2:	MS 348/MK 348 - LED indicators	89
Figure 8.3:	BCL 348 <i>i</i> - Display	90
Figure 9.1:	Connecting the SERVICE USB interface	92
Figure 9.2:	The start page of the webConfig tool	94
Figure 9.3:	Module overview in the webConfig tool	95
Figure 10.1:	BCL 348 <i>i</i> - MS 348 hood with integrated M12 connectors	98
Figure 10.2:	BCL 348 <i>i</i> - MK 348 terminal hood with spring-loaded terminals	99
Figure 10.3:	Assignment of the device names to IP addresses	102
Figure 10.4:	Assigning the device names to the configured IO devices	103
Figure 10.5:	MAC address - IP address - individual device name	104
Table 10.1:	Device parameters	109

Table 10.2:	Module overview	114
Table 10.3:	Parameters for modules 1-4.....	116
Table 10.4:	Parameters for module 5.....	118
Table 10.5:	Parameters for module 7.....	119
Table 10.6:	Parameters for module 10.....	120
Table 10.7:	Output data for module 10	120
Table 10.8:	Parameters for module 11.....	122
Table 10.9:	Parameters for module 12.....	124
Table 10.10:	Input data for module 12.....	124
Table 10.11:	Parameters for module 13.....	125
Table 10.12:	Input data for module 13	125
Table 10.13:	Parameters for module 13.....	126
Table 10.14:	Input data for module 20	127
Table 10.15:	Input data for modules 21 ... 27.....	129
Table 10.16:	Parameters for module 30.....	131
Table 10.17:	Input data for module 31	132
Table 10.18:	Input data for module 32	133
Table 10.19:	Input data for module 33	133
Table 10.20:	Input data for module 34	134
Table 10.21:	Input data for module 35	134
Table 10.22:	Input data for module 36	135
Table 10.23:	Input data for module 37.....	135
Table 10.24:	Input data for module 38	136
Table 10.25:	Input data for module 39	137
Table 10.26:	Input data for module 40	137
Table 10.27:	Input data for module 41	138
Table 10.28:	Parameters for module 50.....	139
Table 10.29:	Parameters for module 51.....	141
Table 10.30:	Parameters for module 52.....	142
Table 10.31:	Parameters for module 53.....	143
Table 10.32:	Parameters for module 54.....	146
Table 10.33:	Parameters for module 55.....	148
Table 10.34:	Input data for module 60	149
Table 10.35:	Output data for module 60	149
Table 10.36:	Parameters for module 61.....	150
Table 10.37:	Input data for module 63	151
Table 10.38:	Output data for module 63	151
Table 10.39:	Parameters for module 64.....	152
Figure 10.6:	Example 1: Start-up delay > 0 and switch-on time = 0.....	153
Figure 10.7:	Example 2: Start-up delay > 0 and switch-on time > 0.....	153
Figure 10.8:	Example 3: start-up delay > 0 switch-off signal prior to lapsing of the start-up delay	154
Figure 10.9:	Start-up delay in input mode	155
Figure 10.10:	Switch-on time in input mode	155

Figure 10.11:	Switch-off delay in input mode.....	156
Table 10.40:	Switch-on/switch-off functions	156
Table 10.41:	Input functions	157
Table 10.42:	Parameters for module 70 – Input/Output 1	157
Table 10.43:	Parameters for module 71 – Input/Output 2	159
Table 10.44:	Input data for module 74 Input/output status and control	161
Table 10.45:	Output data for module 74 Input/output status and control.....	162
Table 10.46:	Parameters for module 80	163
Table 10.47:	Parameters for module 81 – Reference code comparison	164
Table 10.48:	Parameters for module 82 – Reference code comparison	166
Table 10.49:	Parameter module 83 – Reference code comparison pattern	168
Table 10.50:	Parameter module 84 – Reference code comparison pattern	169
Table 10.51:	Input data for module 90 – Status and control.....	171
Table 10.52:	Parameters for module 91 – AutoreflAct.....	172
Table 10.53:	Parameters for module 92 – AutoControl	173
Table 10.54:	Input data for module 92 – AutoControl.....	173
Table 10.55:	Device parameters for example configuration 2	176
Table 10.56:	Device parameters for example configuration 3	178
Table 10.57:	Module parameters for example configuration 3	179
Table 12.1:	General causes of errors	199
Table 12.2:	Interface error	200
Table 13.2:	Connection hoods for the BCL 348 <i>i</i>	203
Table 13.3:	Connectors for the BCL 348 <i>i</i>	203
Table 13.4:	Service cable for the BCL 348 <i>i</i>	203
Table 13.5:	Mounting devices for the BCL 348 <i>i</i>	203
Table 13.6:	Reflector for autoReflAct operation.....	203
Table 13.7:	PWR cables for the BCL 348 <i>i</i>	204
Figure 13.8:	Cable configuration PROFINET-IO connection cable.....	205
Table 13.9:	Bus connection cable for the BCL 348 <i>i</i>	206
Figure 15.1:	Declaration of conformity BCL 308 <i>i</i>	208
Figure 15.2:	Connection hood / connector unit declaration of conformity.....	209
Figure 15.3:	Bar code sample labels (module 0.3)	214
Figure 15.4:	Bar code sample labels (module 0.5)	215

1 General information

1.1 Explanation of symbols

The symbols used in this technical description are explained below.



Attention!

This symbol precedes text messages which must strictly be observed. Failure to comply with this information results in injuries to personnel or damage to the equipment.



Attention Laser!

This symbol warns of possible danger caused by hazardous laser radiation.



Notice!

This symbol indicates text passages containing important information.

1.2 Declaration of conformity

The bar code readers of the BCL 300*i* series have been developed and manufactured in accordance with the applicable European standards and directives.



Notice!

You can find the Declaration of Conformity of the devices in the appendix of the manual on page 145.

The manufacturer of the product, Leuze electronic GmbH & Co KG in D-73277 Owen, possesses a certified quality assurance system in accordance with ISO 9001.



2 Safety notices

2.1 General safety notices

Documentation

All entries in this technical description must be heeded, in particular the present chapter "Safety notices". Keep this technical description in a safe place. It should be available at all times.

Safety regulations

Observe the locally applicable regulations and the rules of the employer's liability insurance association.

Repair

Repairs must only be carried out by the manufacturer or an authorized representative.

2.2 Safety standards

The bar code readers of the BCL 300*i* series were developed, manufactured and tested in accordance with the applicable safety standards. They correspond to the state of the art.

2.3 Approved purpose



Attention!

The protection of personnel and the device cannot be guaranteed if the device is operated in a manner not corresponding to its intended use.

Bar code readers of the BCL 300*i* series are conceived as stationary, high-speed scanners with integrated decoders for all current bar codes used for automatic object detection.

In particular, unauthorized uses include:

- in rooms with explosive atmospheres
- operation for medical purposes

Areas of application

The bar code readers of the BCL 300*i* series are especially designed for the following areas of application:

- Storage technology and materials handling, in particular for object identification on fast-moving transport systems
- Pallet transport systems
- Automobile sector
- Omnidirectional reading

2.4 Working safely



Attention!

Access and changes to the device, except where expressly described in this operating manual, are not authorized.

Safety regulations

Observe the locally applicable legal regulations and the rules of the employer's liability insurance association.

Qualified personnel

Mounting, commissioning and maintenance of the device must only be carried out by qualified personnel.

Electrical work must be carried out by a certified electrician.



Attention, laser radiation!

If you look into the beam path over a longer time period, the retina of your eye may be damaged!

Never look directly into the beam path!

Do not point the laser beam of the BCL 348i at persons!

When mounting and aligning the BCL 348i, avoid reflections of the laser beam off reflective surfaces!

The BCL 348i bar code readers correspond to the EN 60825-1 safety standard for a class 2 laser systems. They also comply with the U.S. 21 CFR 1040.10 regulations for a class II laser product except for deviations pursuant to Laser Notice No. 50, dated July 26, 2001.

Radiant Energy: The BCL 348i uses a low power visible laser diode. The emitted wavelength is 655nm. The average laser power is less than 1 mW in accordance with the definition of laser class 2.

Adjustments: Do not attempt any adjustments to or alterations of this product.

Do not remove the protective housing of the bar code reader. There are no user-serviceable parts inside.

The glass optics cover is the only aperture through which laser radiation may be observed on this product. A failure of the scanner motor, while the laser diode continues to emit a laser beam, may cause emission levels to exceed those for safe operation. The bar code reader has protective devices to prevent this occurrence. If, however, a stationary beam is emitted, the failing bar code reader should be disconnected from the voltage supply immediately.

CAUTION: Use of controls or adjustments or performance of procedures other than specified herein may result in hazardous light exposure.

The use of optical instruments or devices in combination with the device increases the danger of eye damage!

The housing of the BCL 348*i* is provided with warning notices A and B above and next to the reading window as shown in the following figure:

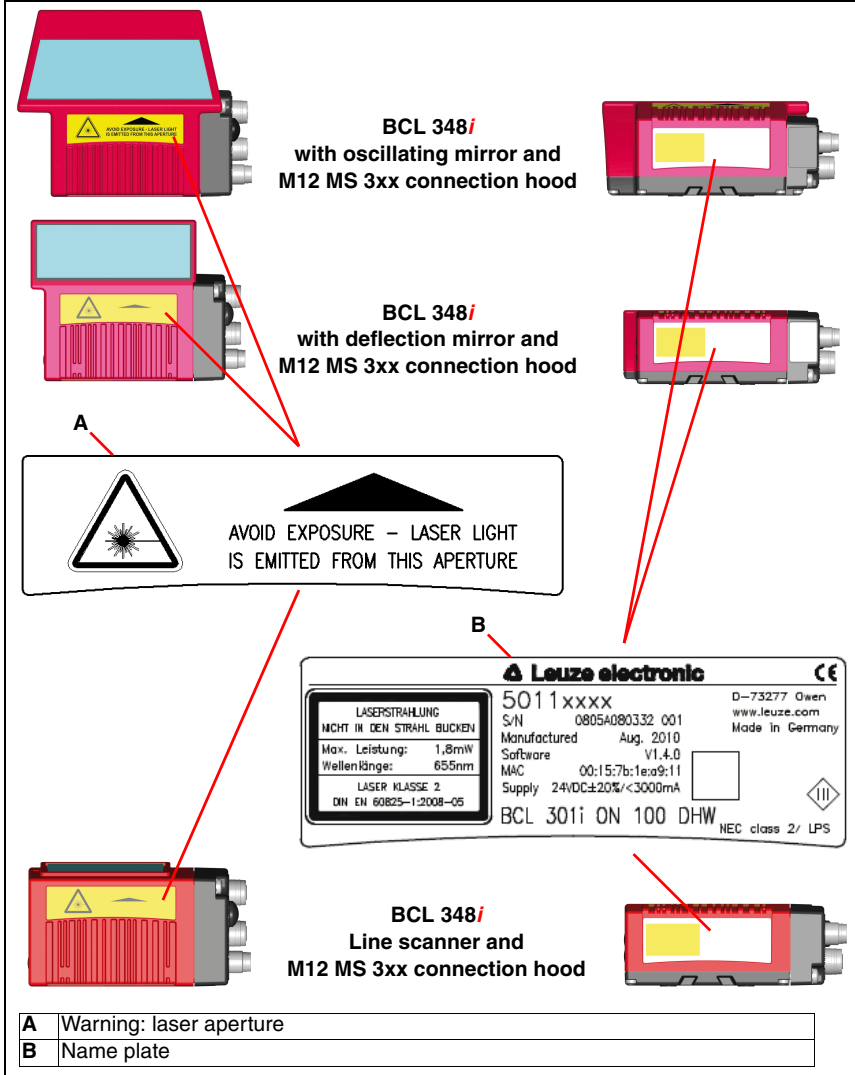

Figure 2.1: Attachment of the stick-on labels with warning notices at the BCL 348*i*

3 Fast commissioning / operating principle

Below you will find a short description for the initial commissioning of the BCL 348*i*. Detailed explanations for all listed points can be found throughout this technical description.

3.1 Mounting the BCL 348*i*

The BCL 348*i* bar code readers can be mounted in two different ways:

- Via four M4x6 screws on the bottom of the device.
- Via a BT 56 mounting device in the fastening groove on the bottom of the housing.

3.2 Device arrangement and selection of the mounting location

In order to select the right mounting location, several factors must be considered:

- Size, orientation, and position tolerance of the bar codes on the objects to be scanned.
- The reading field of the BCL 348*i* in relation to the bar code module width.
- The resulting minimum and maximum reading distance from the respective reading field.
- The permissible cable lengths between the BCL 348*i* and the host system depending on which interface is used.
- The correct time for data output. The BCL 348*i* should be positioned in such a way that, taking into consideration the time required for data processing and the conveyor belt speed, there is sufficient time to e.g. initiate sorting operations on the basis of the read data.
- The display and control panel should be very visible and accessible.
- For configuring and commissioning with the webConfig tool, the USB interface should be easily accessible.

For specific information, please refer to chapter 6 and chapter 7.



Notice!

*The beam exits the BCL 348*i* as follows for the respective devices:*

- line scanner **parallel** to the **housing base**
- deflection mirror **105 degrees** to the **housing base**
- oscillating mirror **perpendicular** to the **housing base**.

The black areas in figure 6.2 are the housing base. The best read results are obtained when:

- *The BCL 348*i* is mounted in such a way that the scanning beam is incident on the bar code at an angle of inclination greater than $\pm 10^\circ$... 15° to vertical.*
- *The reading distance lies in the middle area of the reading field.*
- *The bar code labels are of good print quality and have good contrast ratios.*
- *You do not use high-gloss labels.*
- *There is no direct sunlight.*

3.3 Electrical connection BCL 348*i*

For the electrical connection of the BCL 348*i*, 2 connection variants are available.

The **voltage supply** (18 ... 30VDC) is connected acc. to the connection type selected.

2 freely programmable switching inputs/outputs for individual adaptation to the respective application are also available here. Detailed information on this topic can be found in chapter 7.4.1 and chapter 7.4.3.

MS 348 hood with 2 integrated M12 connectors

Hood with integrated connectors
MS 348

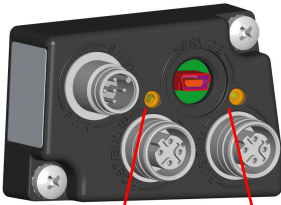

M12 plug
(A-coded)

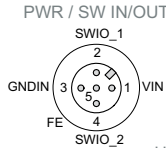

Mini-B USB socket
(behind protective cap)

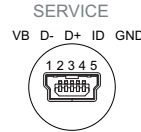

HOST / BUS IN

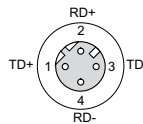

M12 socket
(D-coded)
Ethernet 0

BUS OUT

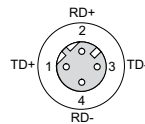

M12 socket
(D-coded)
Ethernet 1

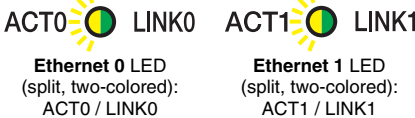

Figure 3.1: BCL 348*i* - MS 348 hood with integrated M12 connectors



Notice!

The shielding connection is done via the M12 connector housing.



Notice!

The integrated parameter memory for the simple replacement of the BCL 348*i* is located in the MS 348. In the integrated parameter memory, both the settings and the PROFINET name are saved and transmitted to a new device.



Notice!

In the case of PROFINET line topology, the network is interrupted when the BCL 348*i* is removed from the MS 348.

MK 348 terminal hood with spring-loaded terminals

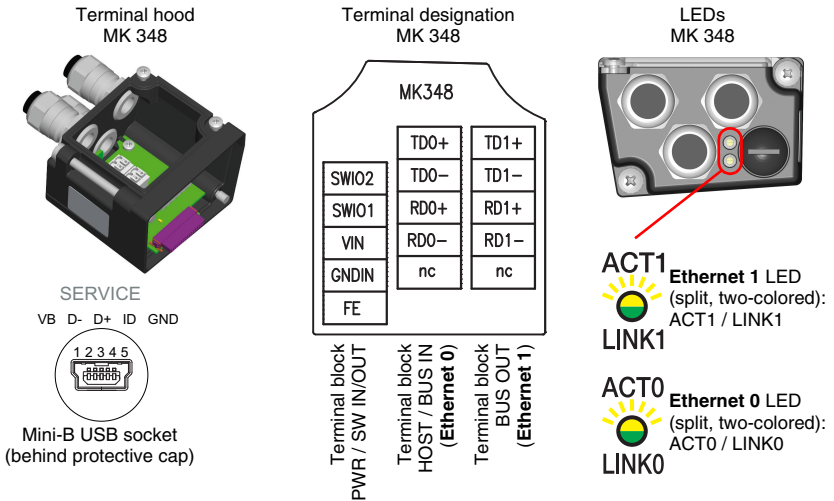

Figure 3.2: BCL 348*i* - MK 348 terminal hood with spring-loaded terminals



Notice!

The integrated parameter memory for simple exchange of the BCL 348*i* is located in the MK 348. In the integrated parameter memory, both the settings and the PROFINET name are saved and transmitted to a new device.



Notice!

In the case of PROFINET line topology, the network is interrupted when the BCL 348*i* is removed from the MK 348.

Cable fabrication and shielding connection

Remove approx. 78mm of the connection cable sheathing. 15mm of sheath of the shielded line must be freely accessible.

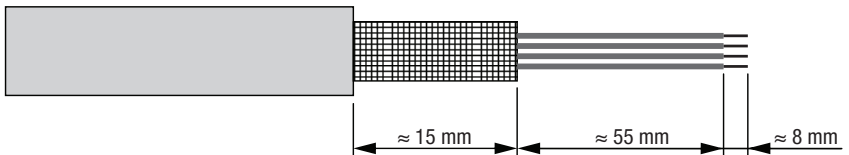

Figure 3.3: Cable fabrication for MK 308 terminal hood

The shield is automatically contacted when the cable is lead into the metal screw fitting and fastened when the cord grip is closed. Then lead the individual wires into the terminals according to the diagram. Wire end sleeves are not necessary.

3.4 Preparatory PROFINET-IO settings

- ↳ *Connect the supply voltage +18 ... 30VDC (typ. +24VDC); the BCL 348*i* starts up and the bar code reading window appears on the display:*

First, you need to assign its individual device name to the BCL 348*i*. The PLC must communicate this device name to the participant during the "device naming". Further information may be found below and in chapter "Step 5 – Configuration of the device name - naming the device" on page 103.

3.4.1 Commissioning the BCL 348*i* on the PROFINET-IO

- ↳ *Complete the necessary steps for commissioning a Siemens-S7 control as described below.*

Further information regarding the individual commissioning steps is provided in see chapter 10.4 "Configuration steps for a Siemens Simatic S7 control".

3.4.2 Preparing the control system

↳ In the first step, assign an IP address to the IO Controller (S7 PLC) and prepare the control for a consistent data transmission.

Notice!

If an S7 control is used, you need to ensure that Simatic-Manager Version 5.4 + service pack 5 (V5.4+SP5) or higher is used.

3.4.3 Installing the GSD file

For the subsequent configuration of the IO devices, e.g., BCL 348*i*, the corresponding GSD file must be loaded first. All data in modules required for operating the BCL 348*i* is described in this file. These are input and output data and device parameters for the functioning of the BCL 348*i* and the definition of the control and status bits.

↳ Install the GSD file associated with the BCL 348*i* in the PROFINET-IO Manager of your control.

3.4.4 Configuration

↳ Configure the PROFINET-IO system with the HW Config of the SIMATIC Manager by inserting the BCL 348*i* into your project.

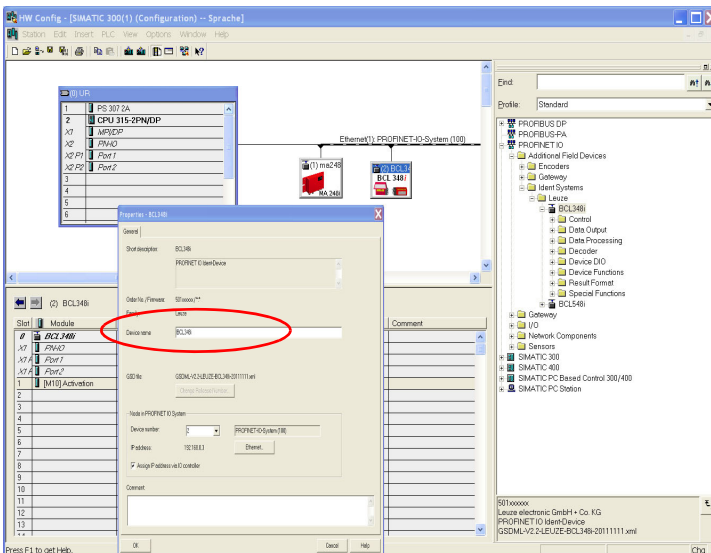

Figure 3.4: Assignment of the device names to IP addresses

Here, an IP address is assigned to a unique "device name".

3.4.5 Transfer of the configuration to the IO Controller

↳ *Transfer the PROFINET-IO configuration to the IO Controller (S7 PLC).*

After the correct transfer to the IO Controller (S7 PLC), the PLC automatically carries out the following activities:

- Check device names
- Assignment of the IP addresses that were configured in the HW Config to the IO devices
- Establishment of a connection between the IO Controller and configured IO devices
- Cyclical data exchange

Notice!

Participants that have not been "named" cannot be contacted yet at this point in time!

3.4.6 Configuration of the device name - device naming

PROFINET-IO defines the "naming of the device" as the creation of a name-based relationship for a PROFINET-IO device.

Assigning the device names to the configured IO devices

Select the respective bar code scanner BCL 348*i* for the "device naming" based on its MAC address.

The unique "device name" (which must match the participant in the HW Config) is then assigned to this participant.



Notice!

Multiple BCL 348*i* can be distinguished by the MAC addresses displayed. The MAC address may be found on the name plate of the respective bar code scanner.

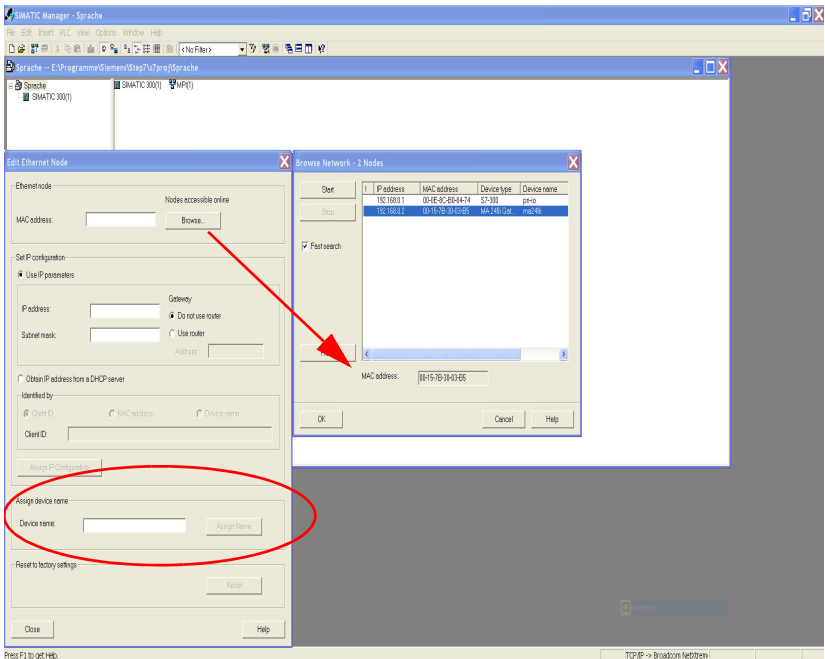

Figure 3.5: Assigning the device names to the configured IO devices

Assignment of MAC address - IP address -individual device name

- ✎ At this point, assign an IP address (suggested by the PLC), a subnet mask and, if required, a router address, and assign this data to the named participant ("device name").

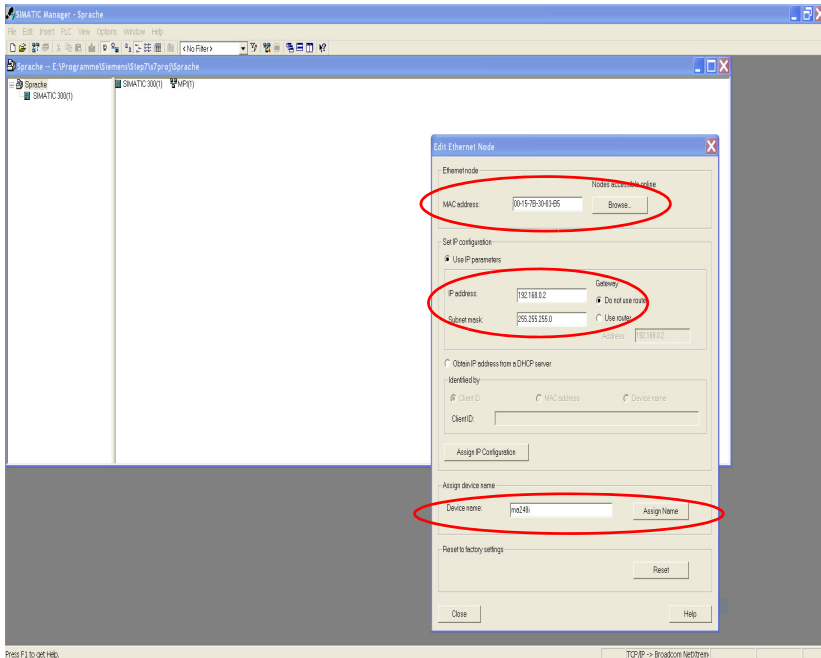

Figure 3.6: MAC address - IP address -individual device name

From now on, and when programming, only the unique "device name" (max. 255 characters) is used.

3.4.7 Check device name

- ✎ After completing the configuration phase, recheck the "device names" that have been assigned. Please ensure that these names are unique and that all participants are located in the same subnet.

3.5 Further settings

Carry out further settings via the PROFINET-IO Controller, such as the control of the decoding and processing of the read data and the configuration of the connected switching inputs and outputs, using the parameters provided by the GSD file.







- ✎ Activate the desired modules (at least module 10 and one of the modules 21 ... 27).

3.6 Starting the device

↳ Connect the +18 ... 30VDC supply voltage (typ. +24VDC).

The BCL 348*i* starts up, the **PWR** and **BUS** LEDs display the operating state. If there is a display, the bar code reading window appears in it.

PWR LED

	flashes green	Device ok, initialization phase
	green continuous light	Power On, device OK
	green, briefly off - on	Good read, successful reading
	green, briefly off - briefly red - on	No read, reading not successful
	yellow continuous light	Service mode
	flashes red	Warning set
	red continuous light	Error, device error

BUS LED

flashes green

Initialization



green continuous light

Network operation OK



flashes red

Communication error



red continuous light

Network error

LED ACT0 / LINK0 (on the MS 308/MK308)green continuous light
yellow flickering lightEthernet connected (LINK)
Data communication (ACT)**LED ACT1 / LINK1 (on the MS 308/MK308)**green continuous light
yellow flickering lightEthernet connected (LINK)
Data communication (ACT)

If a display is available, the following information appears successively during startup:

- Startup
- Device designation e.g. BCL 348i SM 102 D
- Reading Result

If Reading Result is displayed, the device is ready.

Operation of BCL 348i

After voltage (18 ... 30VDC) has been connected to the switching input, a read process is activated. In the standard setting, all common code types for decoding are released; only the **2/5 Interleaved** code type is limited to 10 digits of code content.

If a code is moved through the reading field, the code content is decoded and forwarded to the superior system (PLC/PC) via the PROFINET-IO.

3.7 Bar code reading

To test, you can use the following bar code in the 2/5 Interleaved format. The bar code module here is 0.5:



Provided your BCL 348*i* model has a display, the read information appears on this display. The **PWR** LED goes off briefly and then turns green again. Simultaneously, the read information is forwarded to the superior system (PLC/PC) via the PROFINET-IO.

Please check the incoming data of the bar code information there.

Alternatively, you can use a switching input for read activation (switching signal of a photoelectric sensor or 24VDC switching signal).

4 Device description

4.1 About the bar code readers of the BCL 300*i* series

Bar code readers of the BCL 300*i* series are high-speed scanners with integrated decoder for all commonly used bar codes, e.g. 2/5 Interleaved, Code 39, Code 128, EAN 8/13 etc., as well as codes from the GS1 DataBar family.

Bar code readers of the BCL 300*i* series are available in various optics models as well as line scanners, line scanners with deflection mirrors, oscillating mirrors and also optionally as heated models.

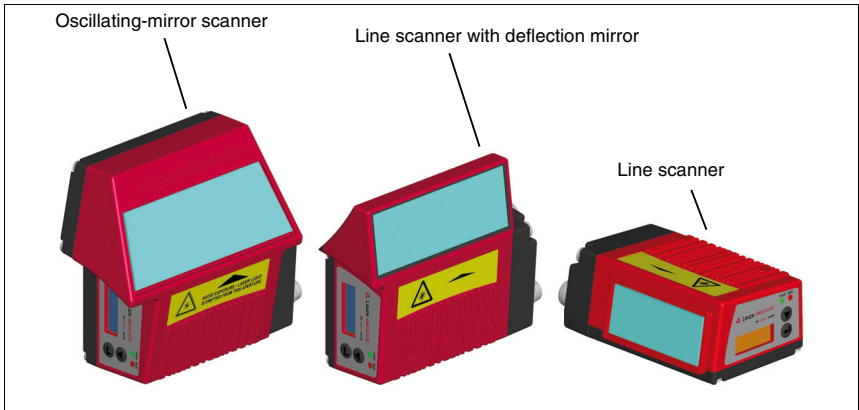

Figure 4.1: Line scanner, line scanner with deflection mirror and oscillating-mirror scanner

The extensive options for device configuration enable adaptation to a multitude of reading tasks. Due to the large reading distance combined with the great depth of field, a large opening angle and a very compact construction, the device is ideally suited for the conveyor and storage technology market.

The interfaces (**RS 232**, **RS 485** and **RS 422**) integrated in the various device models and the fieldbus systems (**PROFIBUS DP**, **PROFINET-IO** and **Ethernet**) offer optimum connection to the superior host system.

4.2 Characteristics of the bar code readers of the BCL 300*i* series

Performance characteristics:

- Integrated fieldbus connectivity = *i* -> Plug-and-Play fieldbus coupling and easy networking
- Numerous interface variants facilitate connection to the superior systems
 - RS 232, RS 422
 - RS 485 and multiNet plus slavealternatively, various fieldbus systems, such as
 - PROFIBUS DP
 - PROFINET-IO
 - EtherNet
- Integrated code fragment technology (**CRT**) enables the identification of soiled or damaged bar codes
- Maximum depth of field and reading distances from 30mm to 700mm
- Large optical opening angle and, thus, large reading field width
- High scanning rate of 1000 scans/s for fast reading tasks
- On request with display to easily detect and activate functions and status messages.
- Integrated USB service interface, Mini-B type
- Adjustment of all device parameters with a web browser
- Easy alignment- and diagnostics functions
- Up to four possible connection technologies
- Two freely programmable switching inputs/outputs for the activation or signaling of states
- Automatic monitoring of the read quality with **autoControl**
- Automatic recognition and setting of the bar code type using **autoConfig**
- Reference code comparison
- Optional heating models to -35°C
- Heavy-duty housing of protection class IP 65



Notice!

Information on technical data and characteristics can be found in Kapitel 5.

General information

The integrated fieldbus connectivity = *i* contained in the bar code readers of the BCL 300*i* series facilitates the use of identification systems which function without connector unit or gateways. The integrated fieldbus interface considerably simplifies handling. The Plug-and-Play concept enables easy networking and very simple commissioning: Directly connect the respective fieldbus and all configuration is performed with no additional software.

For decoding bar codes, the bar code readers of the BCL 300*i* series make available the proven **CRT decoder** with code fragment technology:

The proven code fragment technology (**CRT**) enables bar code readers of the BCL 300*i* series to read bar codes with a small bar height, as well as bar codes with a damaged or soiled print image.

With the aid of the **CRT decoder**, bar codes can also be read without problem in other demanding situations, such as with a large tilt angle (azimuth angle or even twist angle).

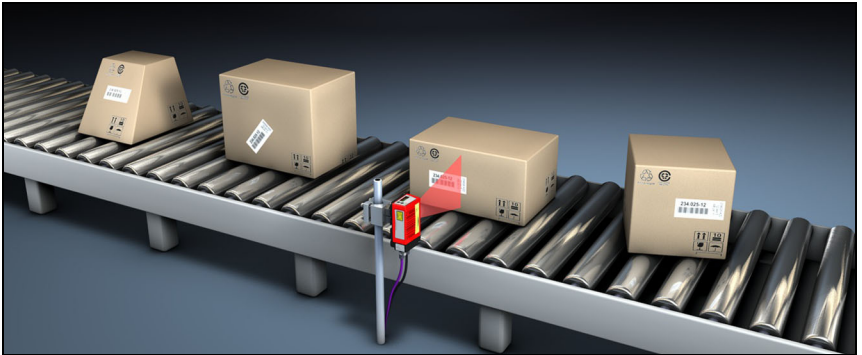

Figure 4.2: Possible bar code orientation

With the BCL 348*i*, configuration is generally performed with the aid of the GSD file.

The BCL 348*i* needs a suitable activation to start a read process as soon as an object is in the reading field. This opens a time window ("reading gate") in the BCL 348*i* for the read process during which the bar code reader has time to detect and decode a bar code.

Alternative activation options include online commands via the host interface and the In the basic setting, triggering takes place through an external reading cycle signal or via the PROFINET-IO. An alternative option for activation is the **autoRefIAct** function.

Through the read operation, the BCL 348*i* collects additional useful pieces of data for diagnosis which can also be transmitted to the host. The quality of the read operation can be inspected using the **alignment mode** which is integrated in the webConfig tool.

An optional display in English with buttons is used to operate the BCL 348*i* as well as for visualization purposes. Two LEDs provide additional optical information on the current operating state of the device.

The two freely configurable switching inputs/outputs **SWIO1** and **SWIO2** can be assigned various functions and control e.g. activation of the BCL 348*i* or external devices, such as a PLC.

System, warning and error messages provide assistance in setup/troubleshooting during commissioning and read operation.

4.3 Device construction

BCL 348i bar code readers

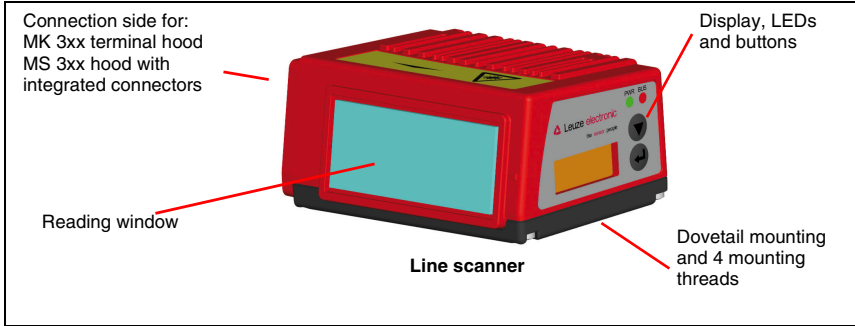

Figure 4.3: BCL 348*i* device construction - line scanner

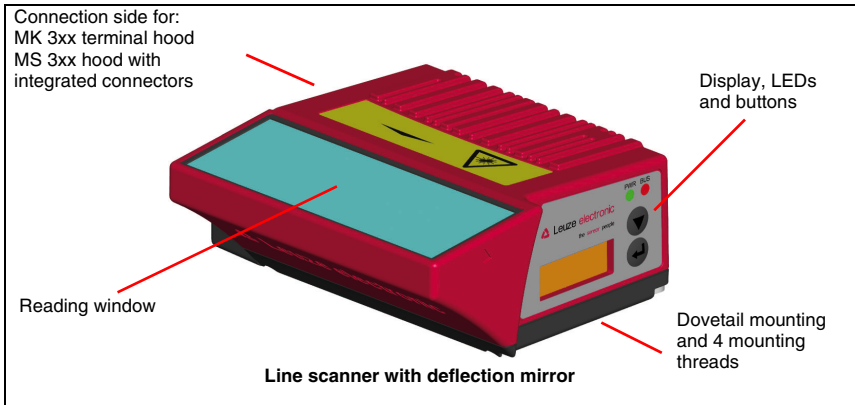

Figure 4.4: BCL 348*i* device construction -line scanner with deflection mirror

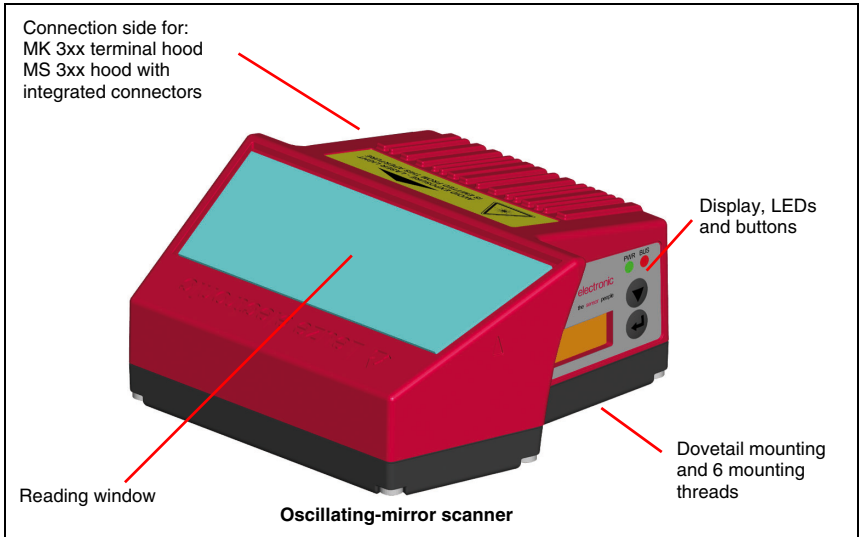

Figure 4.5: BCL 348*i* device construction - oscillating-mirror scanner

MS 348 hood with integrated connectors

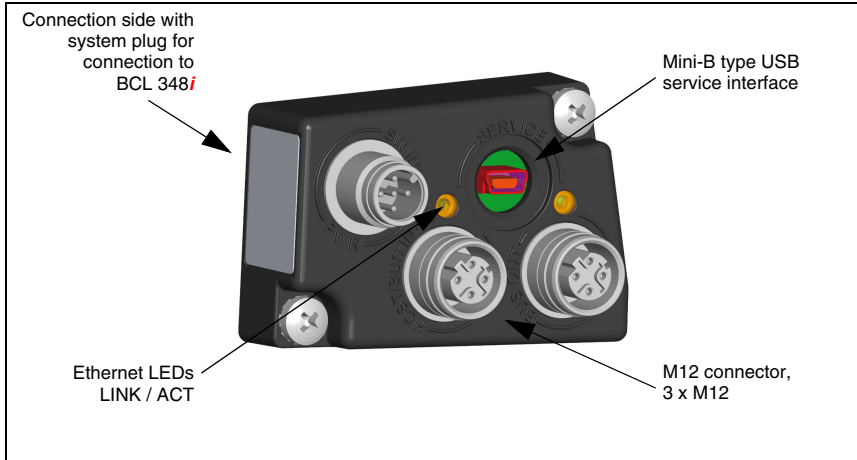

Figure 4.6: Device construction MS 348 hood with integrated connectors

MK 348 terminal hood

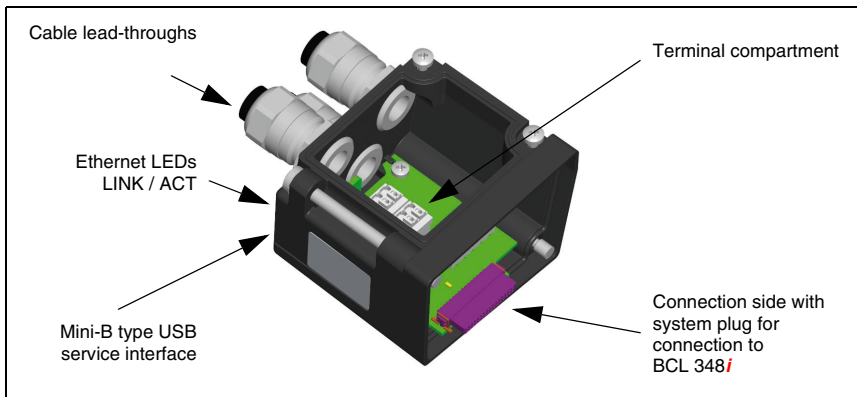

Figure 4.7: Device construction MK 348 hood with integrated connectors

4.4 Reading techniques

4.4.1 Line scanner (single line)

A line (scan line) scans the label. Due to the opt. opening angle, the reading field width is dependent on the read distance. Through the movement of the object, the entire bar code is automatically transported through the scan line.

The integrated code fragment technology permits twisting of the bar code (tilt angle) within certain limits. These are dependent on the transport speed, the scanning rate of the scanner and the bar code properties.

Areas of application of the line scanner

The line scanner is used:

- when the bars of the bar code are printed in the conveying direction ('ladder arrangement').
- with bar codes having very short bar lengths.
- when the ladder code is turned out of the vertical position (tilt angle).
- when the reading distance is large.



Figure 4.8: Deflection principle for the line scanner

4.4.2 Line scanner with oscillating mirror

The oscillating mirror deflects the scan line additionally to both sides across the scan direction at a randomly adjustable oscillation frequency. In this way, the BCL 348*i* can also scan larger areas or spaces for bar codes. The reading field height (and the scan line length useful for evaluation) depends on the reading distance due to the optical opening angle of the oscillating mirror.

Areas of application of the line scanner with oscillating mirror

For line scanners with oscillating mirror, oscillation frequency, start/stop position etc. are adjustable. It is used:

- when the position of the label is not fixed, e.g. on pallets – various labels can, thus, be detected at various positions.
- when the bars of the bar code are printed perpendicular to the conveying direction ('picket fence arrangement').
- when reading stationary objects.
- when a large reading field (reading window) has to be covered.

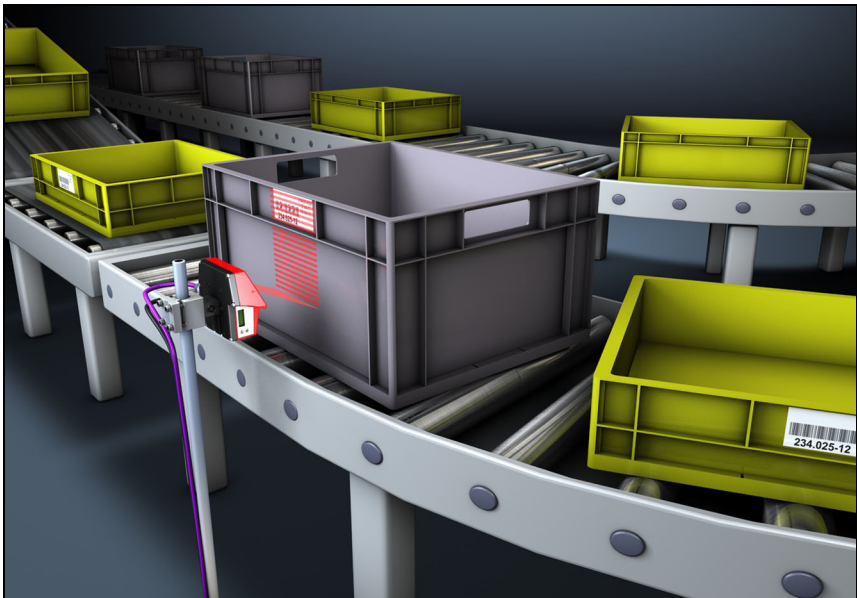

Figure 4.9: Deflection principle for the line scanner with oscillating mirror add-on

4.4.3 Raster scanner (Raster Line)

Multiple scan lines scan the label. Due to the optical opening angle, the reading field width is dependent on the reading distance. Provided the code is located in the reading field, it can be read during standstill. If the code moves through the reading field, it is scanned by multiple scan lines.

The integrated code fragment technology permits twisting of the bar code (tilt angle) within certain limits. These are dependent on the transport speed, the scanning rate of the scanner and the bar code properties. In most cases, everywhere a line scanner is used, a raster scanner can be used.

Areas of application of the raster scanner:

The raster scanner is used:

- when the bars of the bar code are perpendicular to the conveying direction ('picket fence arrangement')
- with bar codes with low height displacement
- with very glossy bar codes



Figure 4.10: Deflection principle for the raster scanner

4.5 Fieldbus systems

Various product variants of the BCL 300*i* series are available for connecting to different fieldbus systems such as PROFIBUS DP, PROFINET-IO and Ethernet.

4.5.1 PROFINET-IO

The BCL 348*i* is designed as a PROFINET-IO device (acc. to IEEE 802.3). It supports a transmission rate of up to 100 Mbit/s (100Base TX/FX), full duplex, as well as auto-negotiation and auto-crossover.

The functionality of the device is defined via parameter sets which are clustered in modules. These modules are contained in a GSDML file.

Each BCL 348*i* is sealed with a unique MAC-ID. This information is used to assign a unique, plant-specific device name ("NameOfStation") to the device via the "Discovery and Configuration Protocol (DCP)". When configuring a PROFINET-IO system, the assignment of the device names to the configured IO devices creates a name-based relationship for the participating IO devices ("device naming"). Further information can be found in section "Schritt 5 – Einstellen des Gerätenamens - Gerätetaufe" auf Seite 103.

The BCL 348*i* features multiple M12 connectors / sockets for the electrical connection of the supply voltage, the interface and the switching inputs and outputs. Additional information on the electrical connection can be found in Kapitel 7.

The BCL 348*i* supports:

- PROFIBUS-IO device functionality based on the PROFIBUS profile for identification systems
- Modular structure of the IO data
- PROFINET-IO RT (**R**eal **T**ime) communication
- Standard Fast Ethernet (100 Mbit/s) connections (M12 technology)
- Integrated Ethernet switch/ 2 Ethernet ports
- PROFINET-IO Conformance Class B (CC-B)
- I&M support: I&M0

For further details, see Kapitel 10!

Identification & Maintenance Functions

The BCL 348*i* supports the base record I&M0:

Contents	Index	Data type	Description	Value
Header	0	10 bytes	Manufacturer specific Manufacturer specific	
MANUFACTURER_ID	10	UNSIGNED16	Leuze PNO manufacturer ID Leuze manufacturer ID	338
ORDER_ID	12	ASCII string 20 bytes	Leuze order no.	
SERIAL_NUMBER	32	ASCII string 16 bytes	Unique device serial number	Device-dependent
HARDWARE_REVISION	48	UNSIGNED16	Hardware revision number, e.g., "0...65535"	Device-dependent
SOFTWARE_REVISION	50	1xCHAR, 3xUNSIGNED8	Software version number, e.g. V130 correspond to "V1.3.0"	Device-dependent
REVISION_COUNTER	54	UNSIGNED16	Is incremented when updating individual modules. This function is not supported.	0
PROFILE_ID	56	UNSIGNED16	PROFIBUS application profile number	0x0000 (Non Profile)
PROFILE_SPECIFIC_TYPE	58	UNSIGNED16	Info about subchannels and submodules. Not relevant	0x0003 (I/O Module)
IM_VERSION	60	2xUNSIGNED8	Implemented I&M version V 1.1	0x01,0x01
IM_SUPPORTED	62	Bit[16]	Optional I&M records available	0

Table 4.1: Base record I&M0

The BCL 348*i* supports further protocols and services for communication:

- TCP / IP (Client / Server)
- UDP
- DCP
- ARP
- PING

Further information on commissioning can be found in Kapitel 10.

4.5.2 PROFINET-IO – star topology

The BCL 348*i* can be operated as a single device (standalone) with an individual device name in a star topology. The PLC must communicate this device name to the participant during the "device naming".

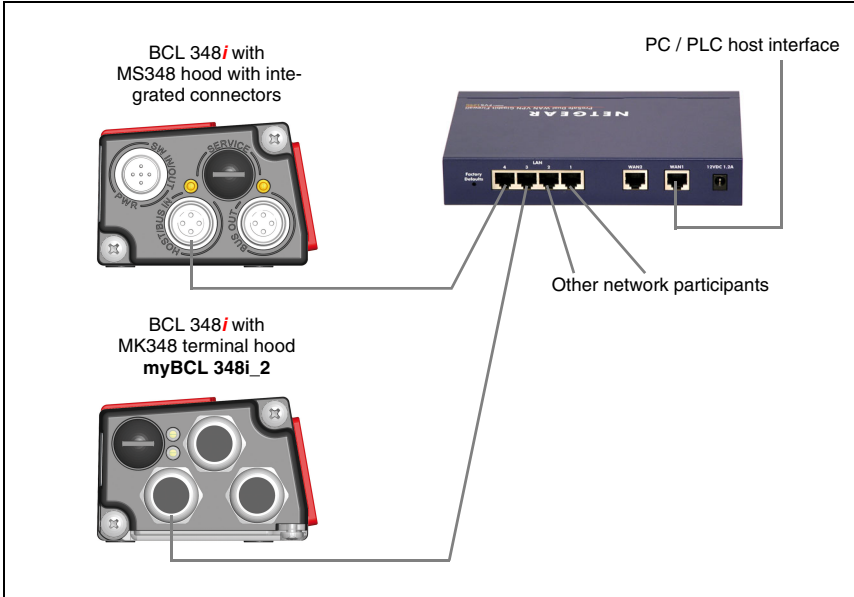

Figure 4.11: PROFINET-IO in a star topology

4.5.3 PROFINET-IO – linear topology

The innovative further development of the BCL 348*i* with integrated switch functionality offers the option of connecting multiple bar code readers of type BCL 348*i* to one another without direct connection to a switch. In addition to the classic "star topology", a "linear topology" is thus also possible.

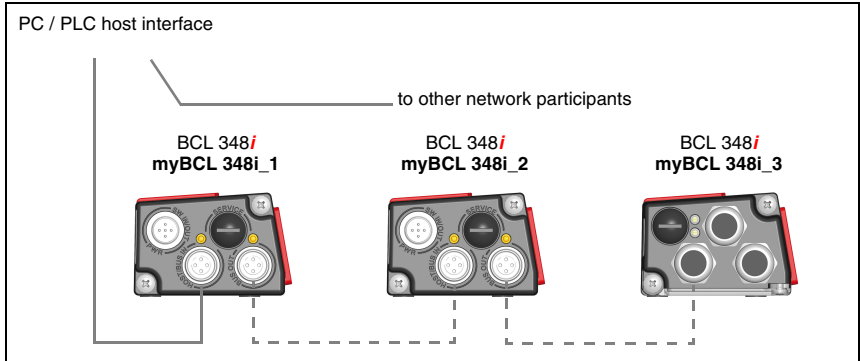

Figure 4.12: PROFINET-IO in a linear topology

Each participant in this network requires its own unique device name that is assigned by the PLC during the "device naming". For specific information, please refer to section "Schritt 5 – Einstellen des Gerätenamens - Gerätetaufe" auf Seite 103.

The maximum length of a segment (connection from the hub to the last participant) is limited to 100m.

4.6 Heater

For low-temperature applications to min. -35°C (e.g. in cold storage), the bar code readers of the BCL 348*i* series can optionally be permanently fitted with a built-in heating and these bar code readers purchased as separate device models.

4.7 External parameter memory in the MS 348 / MK 348

The parameter memory available in the MS 348 or MK 348 simplifies the time saving on-site exchange of a BCL 348*i* by providing a copy of the current parameter set of the BCL 348*i* and by storing the device name as well. This eliminates the need to configure the exchanged device manually and, in particular, a new naming of the device – the control can immediately access the exchanged BCL 348*i*.

4.8 autoReflAct

AutoReflAct stands for **Automatic Reflector Activation** and permits an activation without additional sensors. This is achieved by directing the scanner with reduced scanning beam towards a reflector mounted behind the conveyor path.



Notice!

Compatible reflectors are available on request.

As long as the scanner is targeted at the reflector, the reading gate remains closed. If, however, the reflector is blocked by an object such as a container with a bar code label, the scanner activates the read procedure, and the label on the container is read. When the path from the scanner to the reflector has cleared, the read procedure has completed and the scanning beam is reduced and again directed onto the reflector. The reading gate is closed.

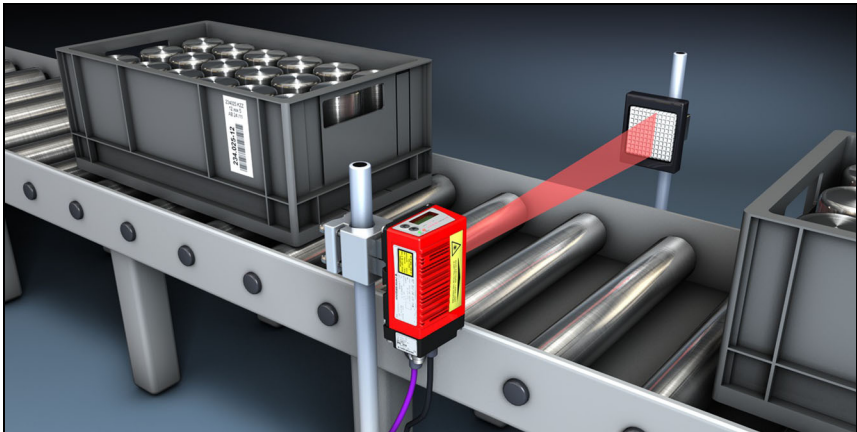

Figure 4.13: Reflector arrangement for autoReflAct

The **autoReflAct** function uses the scanning beam to simulate a photoelectric sensor and thus permits an activation without additional sensor system.

4.9 Reference codes

The BCL 348*i* offers the possibility of storing one or two reference codes.

It is possible to store the reference codes via the webConfig tool, via online commands or PROFINET-IO.

The BCL 348*i* can compare read bar codes with one and/or both reference codes and execute user-configurable functions depending on the comparison result.

4.10 autoConfig

With the autoConfig function, the BCL 348*i* offers the user who only wishes to simultaneously read one code type (symbology) with one number of digits an extremely simple and convenient configuration option.

After starting the autoConfig function via the switching input or from a superior control, it is sufficient to position a bar code label with the desired code type and number of digits in the reading field of the BCL 348*i*.

Afterward, bar codes with the same code type and number of digits are recognized and decoded.



Notice!

The settings made via the webConfig configuration tool push the parameters set in the PROFINET-IO only temporarily into the background. They are overwritten during integration into the PROFINET-IO or after deactivation of service mode of the PROFINET master with those settings made via the GSD file!

Device settings for operating the BCL 348*i* on the PROFINET-IO are managed and configured exclusively by the PROFINET-IO Controller (PLC). Permanent changes must be carried out here!

Detailed information on this topic can be found in Kapitel 10 "Inbetriebnahme und Konfiguration" auf Seite 97.

5 Specifications

5.1 General specifications of the bar code readers

5.1.1 Line scanner / raster scanner

Type	BCL 348<i>i</i> PROFINET-IO
Type	Line scanner without heating
Optical data	
Light source	Laser diode $\lambda = 655\text{nm}$ (red light)
Beam exit	Front
Scanning rate	1000 scans/s
Beam deflection	by means of rotating polygon wheel
Useful opening angle	max. 60°
Optics models / resolution	High Density (N): 0.127 ... 0.20mm Medium Density (M): 0.20 ... 0.5mm Low Density (F): 0.30 ... 0.5mm Ultra Low Density (L): 0.35 ... 0.8mm
Reading distance	see reading field curves
Laser class	2 (acc. to EN 60825-1 and 21 CFR 1040.10 with Laser Notice No. 50)
Bar code data	
Code types	2/5 Interleaved, Code 39, Code 128, EAN 128, EAN / UPC, Codabar, Code 93, GS1 DataBar, EAN Addendum
Bar code contrast (PCS)	$\geq 60\%$
External light tolerance	2000 lx (on the bar code)
Number of bar codes per scan	3
Electrical data	
Interface type	2x PROFINET-IO on 2x M12 (D)
Protocols	PROFINET-IO RT-communication DCP TCP/IP (Client/ Server) / UDP
Baud rate	10/100MBaud
Data formats	
Service interface	Mini-B type USB 2.0 socket
Switching input / switching output	2 switching inputs/outputs, freely programmable functions - Switching input: 18 ... 30VDC depending on supply voltage, I max. = 8mA - Switching output: 18 ... 30VDC, depending on supply voltage, I max. = 60mA (short-circuit proof) Switching inputs/outputs protected against polarity reversal!
Operating voltage	18 ... 30VDC (Class 2, safety class III)
Power consumption	max. 3.7W
Operating and display elements	
Display	monochromatic graphical display, 128 x 32 pixel, with background lighting
Keyboard	2 buttons
LEDs	2 LEDs for power (PWR) and bus state (BUS), two-colored (red/green)

Type	BCL 348<i>i</i> PROFINET-IO
Type	Line scanner without heating
Mechanical data	
Protection class	IP 65 ¹⁾
Weight	270g (without connection hood)
Dimensions (WxHxD)	44 x 95 x 68mm (without connection hood)
Housing	diecast aluminum
Environmental data	
Operating temperature range	0°C ... +40°C
Storage temperature range	-20°C ... +70°C
Air humidity	max. 90% rel. humidity, non-condensing
Vibration	IEC 60068-2-6, test FC
Shock	IEC 60068-2-27, test Ea
Continuous shock	IEC 60068-2-29, test Eb
Electromagnetic compatibility	EN 55022; IEC 61000-6-2 (contains IEC 61000-4-2, -3, -4, -5 and -6) ²⁾

- 1) Only with the MS 348 or MS 348 connection hood and screwed-on M12 connectors or cable lead-throughs and mounted caps. Minimum tightening torque of the housing connection screws on the connection hood 1.4Nm!
- 2) This is a Class A product. In a domestic environment this product may cause radio interference, in which case the operator may be required to take adequate measures.



Attention!

For UL applications, use is permitted exclusively in Class 2 circuits according to NEC (National Electric Code).



The BCL 348*i* bar code readers are designed in accordance with safety class III for supply by PELV (protective extra-low voltage).

5.1.2 Oscillating-mirror scanner

Technical data same as for line scanner without heating with the following differences:

Type	BCL 348<i>i</i> PROFINET-IO
Type	Oscillating-mirror scanner without heating
Optical data	
Beam exit	Lateral zero position at an angle of 90°
Beam deflection	Via rotating polygon wheel (horizontal) and stepping motor with mirror (vertical)
Oscillation frequency	0 ... 10Hz (adjustable, max. frequency is dependent on set swivel angle)
Max. swivel angle	±20°(adjustable)
Reading field height	see reading field curves
Electrical data	
Power consumption	max. 4.9W
Mechanical data	
Weight	580g (without connection hood)
Dimensions (WxHxD)	58 x 125 x 110mm (without connection hood)

Table 5.1: Specifications of the BCL 348*i* oscillating-mirror scanners without heating

5.1.3 Line scanner / raster scanner with deflection mirror

Technical data same as for line scanner without heating with the following differences:

Type	BCL 348<i>i</i> PROFINET-IO
Type	Line scanner with deflection mirror without heating
Optical data	
Beam exit	Lateral zero position at an angle of 90°
Beam deflection	Via rotating polygon wheel (horizontal) and deflection mirror (vertical)
Max. optical adjustment range of the beam exit	±10° (adjustable via display or software)
Electrical data	
Power consumption	max. 3.7W
Mechanical data	
Weight	350g (without connection hood)
Dimensions (WxHxD)	44 x 103 x 96mm (without connection hood)

Table 5.2: Specifications of the BCL 348*i* deflection-mirror scanners without heating

5.2 Heating models of the bar code readers

The BCL 348*i* bar code readers are optionally available as models with integrated heating. In this case, heating is permanently installed ex works. Self-installation on-site by the user is not possible!

Features

- Integrated heating (permanently installed)
- Extends the application range of the BCL 348*i* to -35°C
- Supply voltage 24VDC $\pm 20\%$
- BCL 348*i* enabling through an internal temperature switch (switch-on delay about 30min for 24VDC and minimum ambient temperature of -35°C)
- Necessary conductor cross-section for the voltage supply: at least 0.75mm²; the use of ready-made cables is, thus, not possible

Construction

The heating consists of two parts:

- The front cover heater
- The housing heater

Function

When the 24VDC supply voltage is applied to the BCL 348*i*, a temperature switch initially only connects the heating to current (front cover heater and housing heater). During the heating phase (around 30min), when the inside temperature rises above 15°C, the temperature switch connects the BCL 348*i* to the supply voltage. This is followed by the self test and the changeover to read operation. The "PWR" LED lights up, showing overall readiness for operation.

When the inside temperature reaches approximately 18 °C, another temperature switch turns the housing heater off and, if necessary, back on again (if the inside temperature drops below 15°C). This does not interrupt the read operation. The front cover heater remains activated until an inside temperature of 25°C is reached. At temperatures above this, the front cover heater switches off and, with a switching hysteresis of 3°C, back on again at an inside temperature below 22°C.

Mounting location



Notice!

*The mounting location is to be selected such that it does not expose the BCL 348*i* with heating directly to a cold air stream. To achieve an optimal heating effect, the BCL 348*i* should be mounted so that it is thermally isolated.*

Electrical connection

The required core cross section of the connection cable for the voltage supply must be at least 0.75 mm².



Attention!

The voltage supply must not be looped through from one device to the next.

Power consumption

The energy requirement depends on the model:

- the line/raster scanner with heating typically consumes a maximum of 17W power.
- the line scanner with oscillating mirror and heating typically consumes a maximum of 26W power.
- the line/raster scanner with deflection mirror and heating typically consumes a maximum of 19W power.

These values are based on operation with unconnected switching outputs.

5.2.1 Line scanner / raster scanner with heater

Technical data same as for line scanner without heating with the following differences:

Type	BCL 348<i>i</i> PROFINET-IO
Type	Line scanner with heater
Electrical data	
Operating voltage	24VDC ±20%
Power consumption	max. 17.7W
Structure of the heating	Housing heating and separate heating of the optics glass
Warmup time	Min. 30min at +24VDC and an ambient temperature of -35°C
Min. conductor cross section	Conductor cross section of at least 0.75mm ² for the supply voltage supply line. Wiring through of the voltage supply to multiple heating devices is not permissible. Standard, M12 ready-made cable not usable (insufficient conductor cross section)
Environmental data	
Operating temperature range	-35°C ... +40°C
Storage temperature range	-20°C ... +70°C

Table 5.3: Specifications of the BCL 348*i* line/raster scanners with heating

5.2.2 Oscillating-mirror scanner with heating

Technical data same as for line scanner without heating with the following differences:

Type	BCL 348<i>i</i> PROFINET-IO
Type	Oscillating-mirror scanner with heating
Optical data	
Useful opening angle	max. 60°
Max. swivel angle	± 20°(adjustable)

Table 5.4: Specifications of the BCL 348*i* oscillating-mirror scanners with heating

Type	BCL 348<i>i</i> PROFINET-IO
Type	Oscillating-mirror scanner with heating
Electrical data	
Operating voltage	24VDC ±20%
Power consumption	max. 26.7W
Structure of the heating	Housing heating and separate heating of the optics glass
Warmup time	Min. 30min at +24VDC and an ambient temperature of -35°C
Min. conductor cross section	Conductor cross section of at least 0.75mm ² for the supply voltage supply line. Wiring through of the voltage supply to multiple heating devices is not permissible. Standard, M12 ready-made cable not usable (insufficient conductor cross section)
Environmental data	
Operating temperature range	-35°C ... +40°C
Storage temperature range	-20°C ... +70°C

Table 5.4: Specifications of the BCL 348*i* oscillating-mirror scanners with heating

5.2.3 Line scanner / raster scanner with deflection mirror and heating

Technical data same as for line scanner without heating with the following differences:

5.3 Dimensioned drawings

Type	BCL 348<i>i</i> PROFINET-IO	
Type	Deflection mirror scanner with heating	
Optical data		
Useful opening angle	max. 60°	
Max. adjustment range	±10°(adjustable via display or software)	
Electrical data		
Operating voltage	24VDC ±20%	
Power consumption	max. 19.7W	
Structure of the heating	Housing heating and separate heating of the optics glass	
Warmup time	Min. 30min at +24VDC and an ambient temperature of -35°C	
Min. conductor cross section	Conductor cross section of at least 0.75mm² for the supply voltage supply line. Wiring through of the voltage supply to multiple heating devices is not permissible. Standard, M 12 ready-made cable not usable (insufficient conductor cross section)	
Environmental data		
Operating temperature range	-35°C ... +40°C	
Storage temperature range	-20°C ... +70°C	

Table 5.5: Specifications of the BCL 348*i* deflection mirror scanners with heating

5.3.1 Dimensioned drawing of complete overview of the BCL 348*i* with MS 3xx / MK 3xx

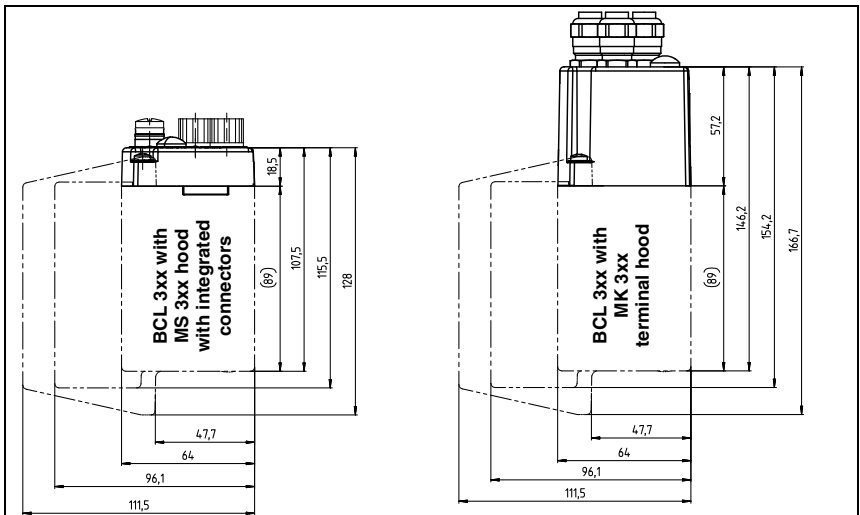

Figure 5.1: Dimensioned drawing of complete overview of the BCL 348*i* with MS 3xx / MK 3xx

5.3.2 Dimensioned drawing of line scanner with / without heating

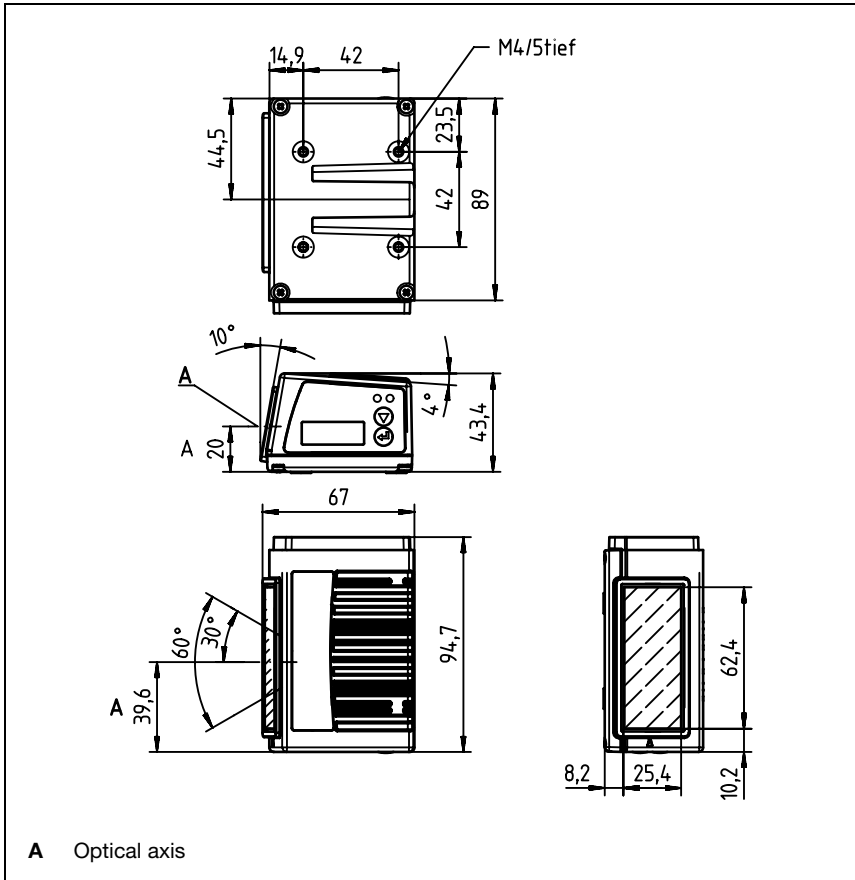

Figure 5.2: Dimensioned drawing BCL 348/i line scanner S...102

5.3.3 Dimensioned drawing of deflection mirror scanner with / without heating

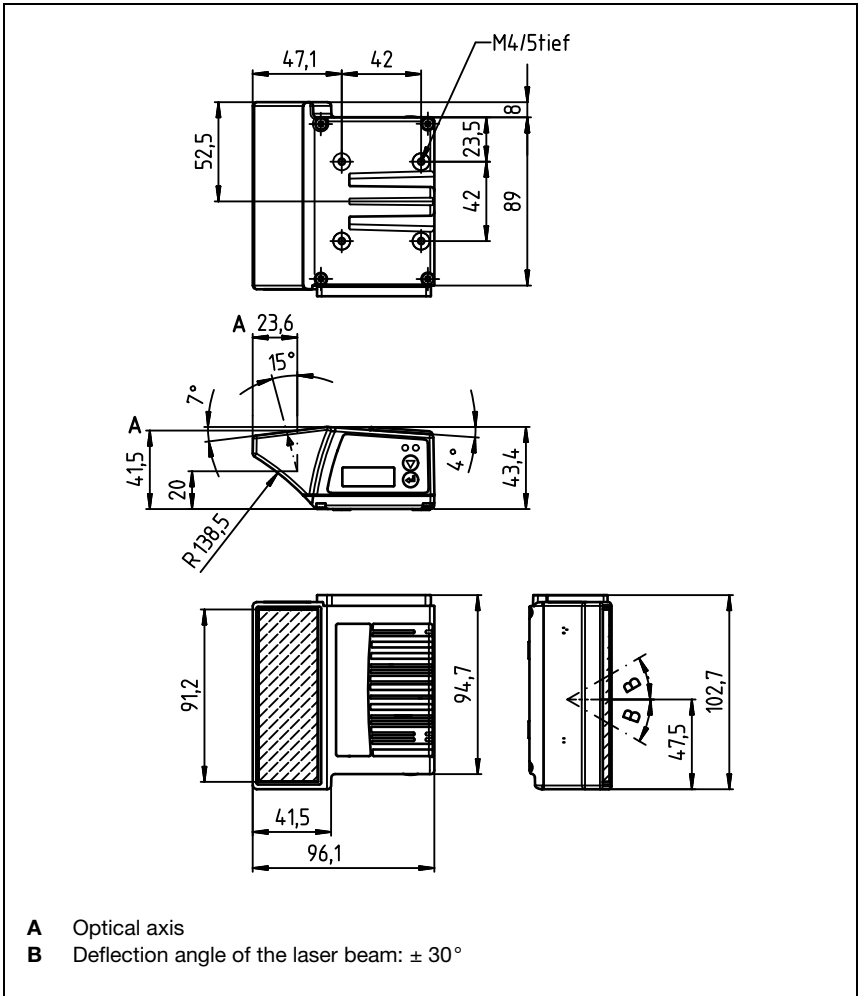

Figure 5.3: Dimensioned drawing BCL 348*i* deflection mirror scanner S...100

5.3.4 Dimensioned drawing of oscillating-mirror scanner with / without heating

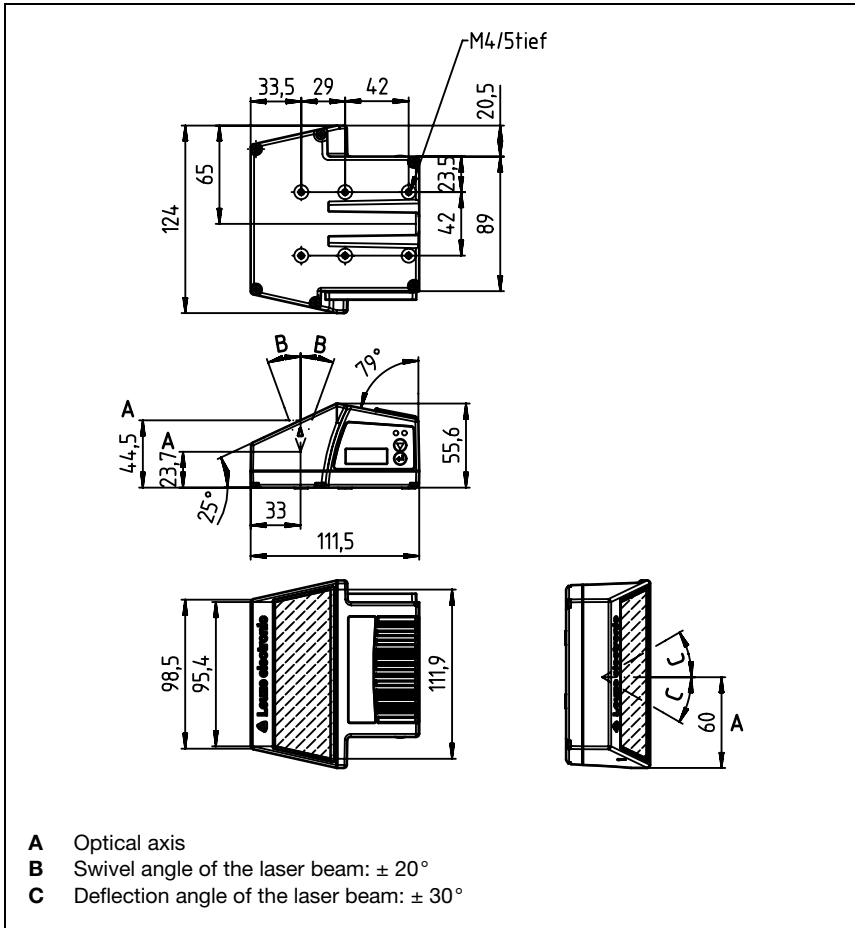

Figure 5.4: Dimensioned drawing BCL 348*i*/oscillating mirror scanner O...100

5.3.5 Dimensioned drawing of MS 3xx hood with integrated connectors / MK 3xx terminal hood

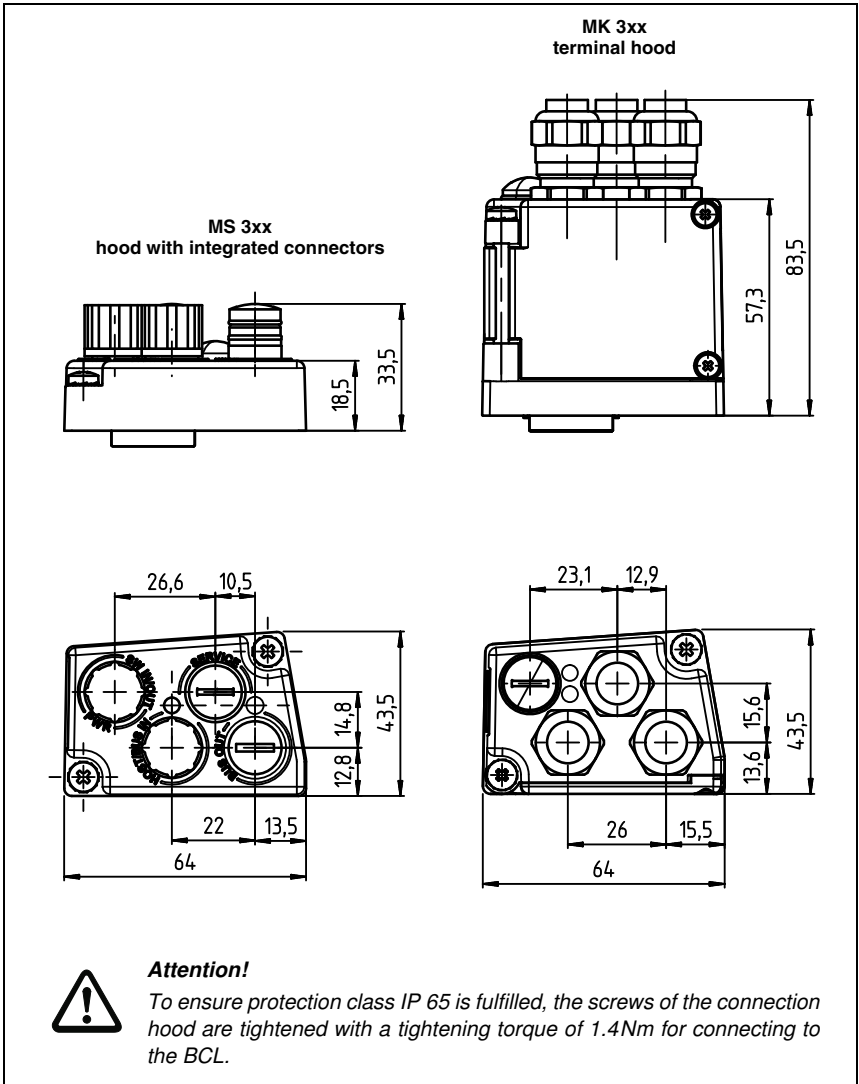

Figure 5.5: Dimensioned drawing of MS 3xx hood with integrated connectors / MK 3xx terminal hood

5.4 Reading field curves / optical data

5.4.1 Bar code characteristics



Notice!

Please note that the size of the bar code module influences the maximum reading distance and the width of the reading field. Therefore, when selecting a mounting location and/or the bar code label, take into account the different reading characteristics of the scanner with various bar code modules.

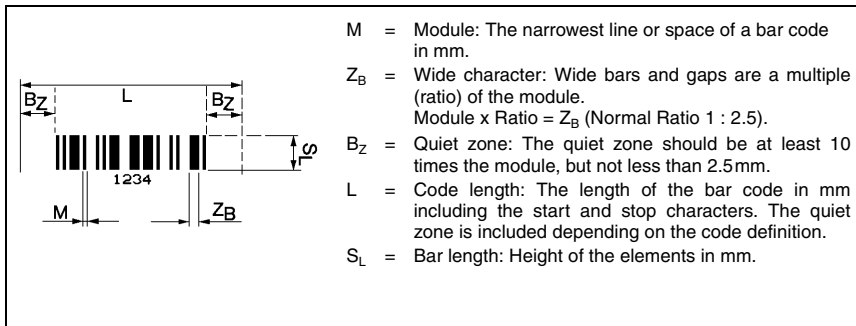

Figure 5.6: The most important characteristics of a bar code

The range in which the bar code can be read by the BCL 348*i* (the so-called reading field) depends on the quality of the printed bar code and its dimensions.

Therefore, above all, the module of a bar code is decisive for the size of the reading field.



Notice!

A rule of thumb: The smaller the module of the bar code is, the smaller the maximum reading distance and reading field width will be.

5.4.2 Raster scanner

A raster variant is also available in the BCL 300*i* series. The BCL 300*i* as a raster scanner projects 8 scan lines which vary depending on the reading distance from the raster aperture.

		Distance [mm] starting at the zero position						
		50	100	200	300	400	450	700
Raster line cover [mm] all raster lines	Front scanner	8	14	24	35	45	50	77
	Deflection mirror scanner	12	17	27	38	48	54	80

Table 5.6: Raster line cover as a function of the distance

5.5 Reading field curves



Notice!

Please notice that the real reading fields are also influenced by factors such as labeling material, printing quality, reading angle, printing contrast etc., and may thus deviate from the reading fields specified here.

The reading field curves also apply for the variants with heating.

The zero position of the reading distance always refers the front edge of the housing of the beam exit and is shown in figure 5.7 for the three housing types of the BCL 348*i*.

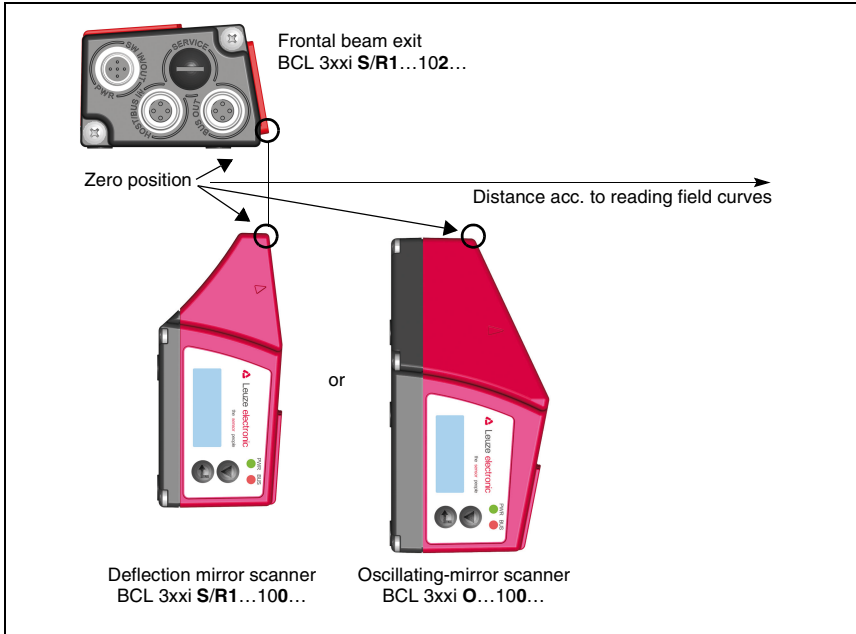

Figure 5.7: Zero position of the reading distance

Reading conditions for the reading field curves

Bar code type	2/5 Interleaved
Ratio	1:2.5
ANSI specification	class A
Reading rate	> 75%

Table 5.7: Reading conditions

5.5.1 High Density (N) - optics: BCL 348*i*/S/R1 N 102 (H)

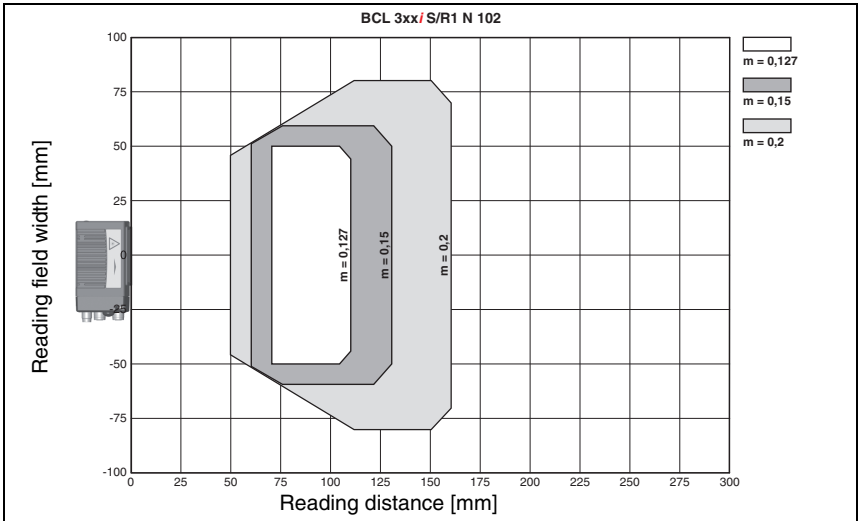

Figure 5.8: "High Density" reading field curve for line scanner without deflection mirror

5.5.2 High Density (N) - optics: BCL 348*i*/S/R1 N 100 (H)

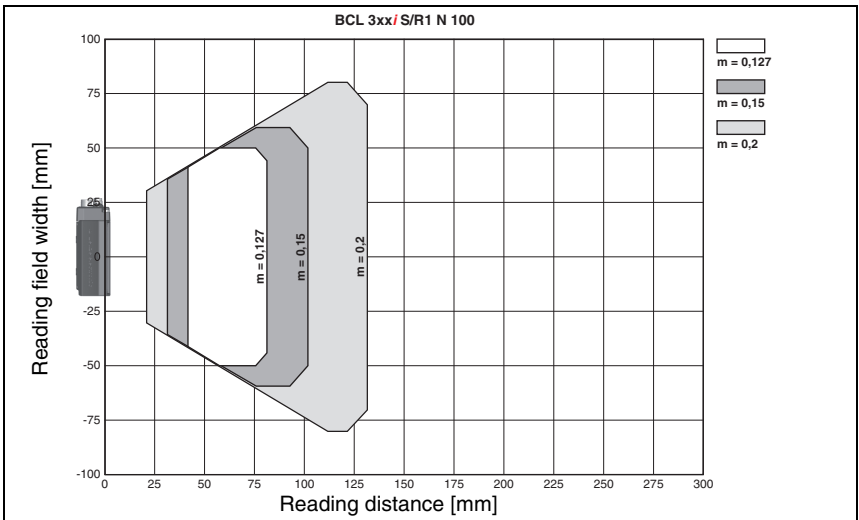

Figure 5.9: "High Density" reading field curve for line scanner with deflection mirror

The reading field curve applies for the reading conditions stated in table 5.7.

5.5.3 High Density (N) - optics: BCL 348*i* ON 100 (H)

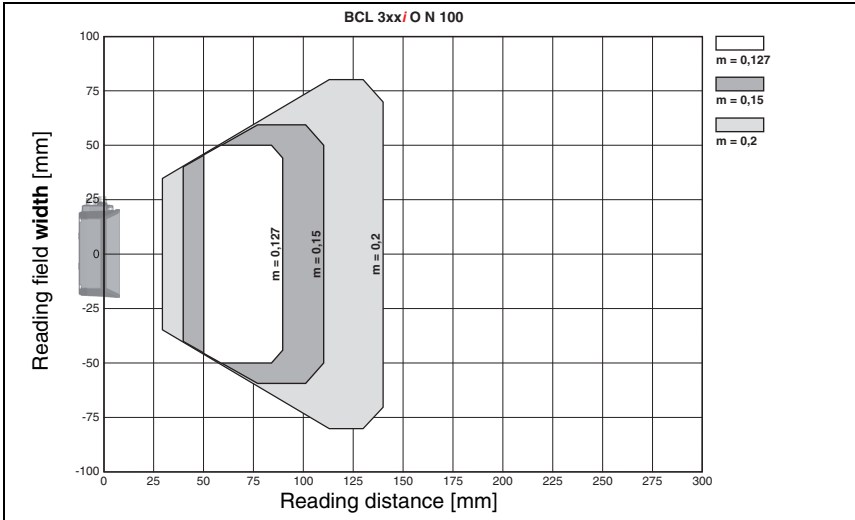

Figure 5.10: "High Density" reading field curve for oscillating-mirror scanners

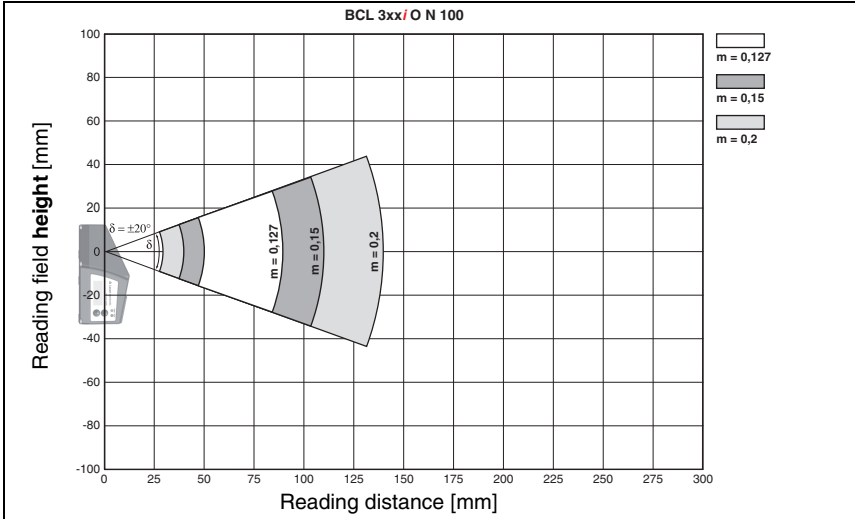

Figure 5.11: Lateral "High Density" reading field curve for oscillating-mirror scanners

The reading field curves apply for the reading conditions stated in table 5.7.

5.5.4 Medium Density (M) - optics: BCL 348*i* S/R1 M 102 (H)

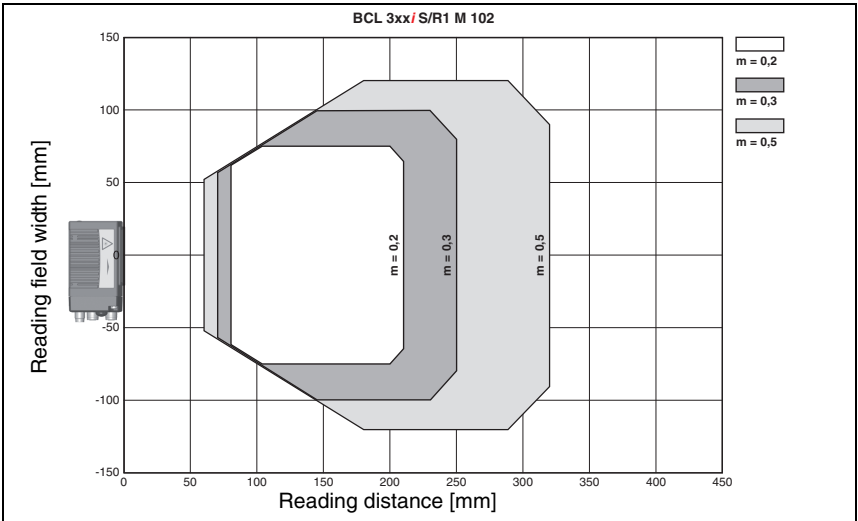

Figure 5.12: "Medium Density" reading field curve for line scanner without deflection mirror

5.5.5 Medium Density (M) - optics: BCL 348*i* S/R1 M 100 (H)

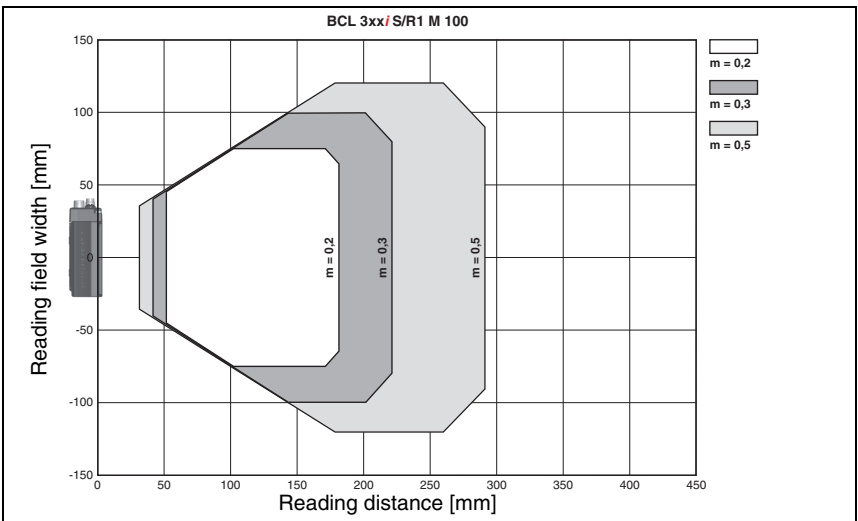

Figure 5.13: "Medium Density" reading field curve for line scanner with deflection mirror

The reading field curves apply for the reading conditions stated in table 5.7.

5.5.6 Medium Density (M) - optics: BCL 348*i* OM 100 (H)

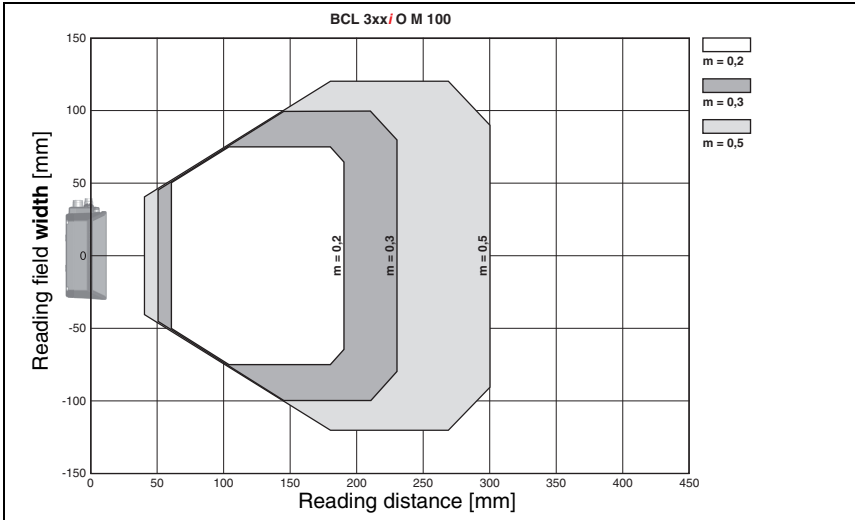

Figure 5.14: "Medium Density" reading field curve for oscillating-mirror scanners

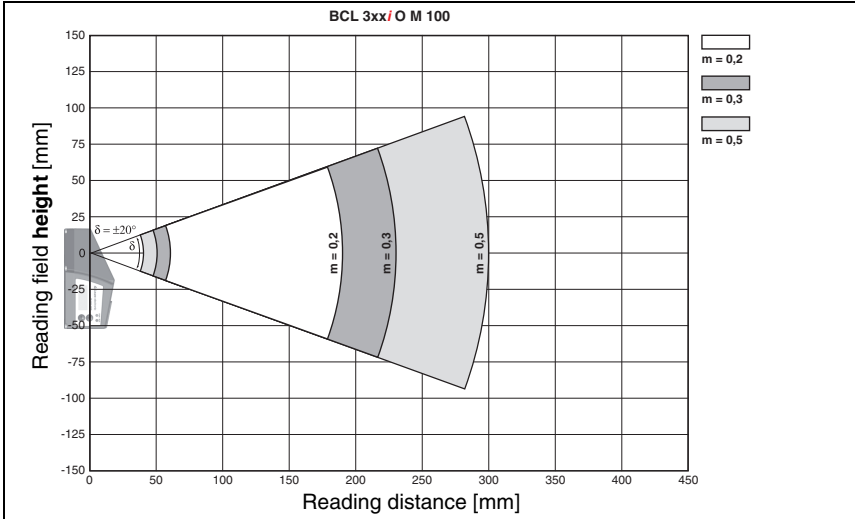

Figure 5.15: Lateral "Medium Density" reading field curve for oscillating-mirror scanners

The reading field curves apply for the reading conditions stated in table 5.7.

5.5.7 Low Density (F) - optics: BCL 348*i* S/R1 F 102 (H)

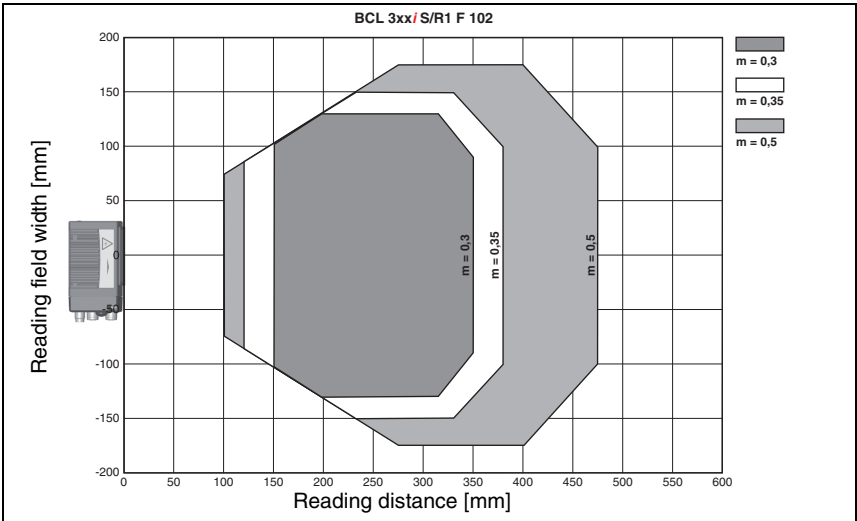

Figure 5.16: "Low Density" reading field curve for line scanner without deflection mirror

5.5.8 Low Density (F) - optics: BCL 348*i* S/R1 F 100 (H)

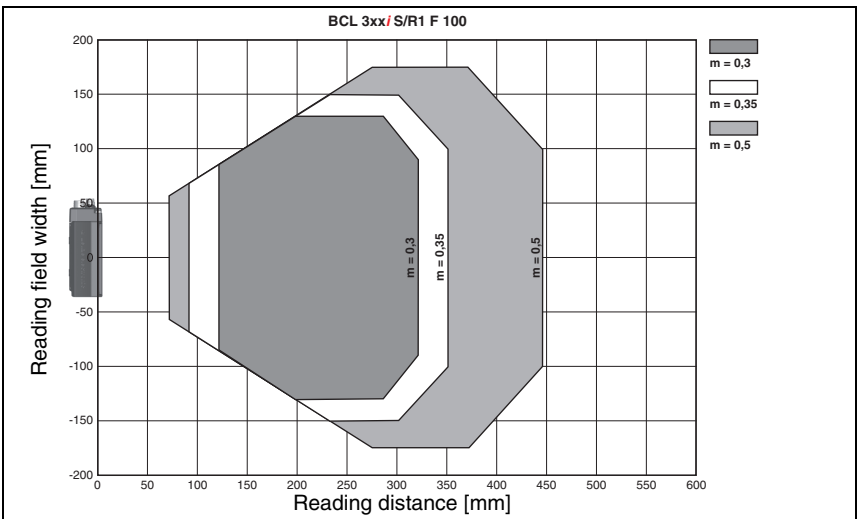

Figure 5.17: "Low Density" reading field curve for line scanner with deflection mirror

The reading field curves apply for the reading conditions stated in table 5.7.

5.5.9 Low Density (F) - optics: BCL 348*i* OF 100 (H)

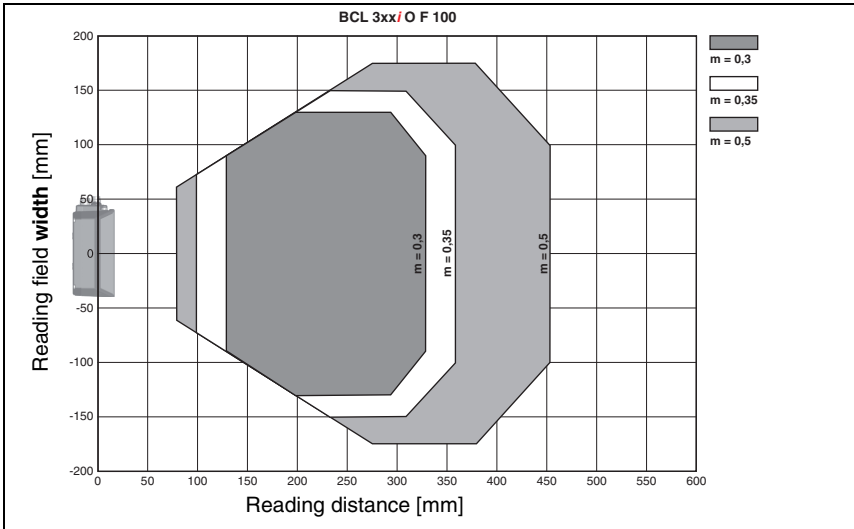

Figure 5.18: "Low Density" reading field curve for oscillating-mirror scanners

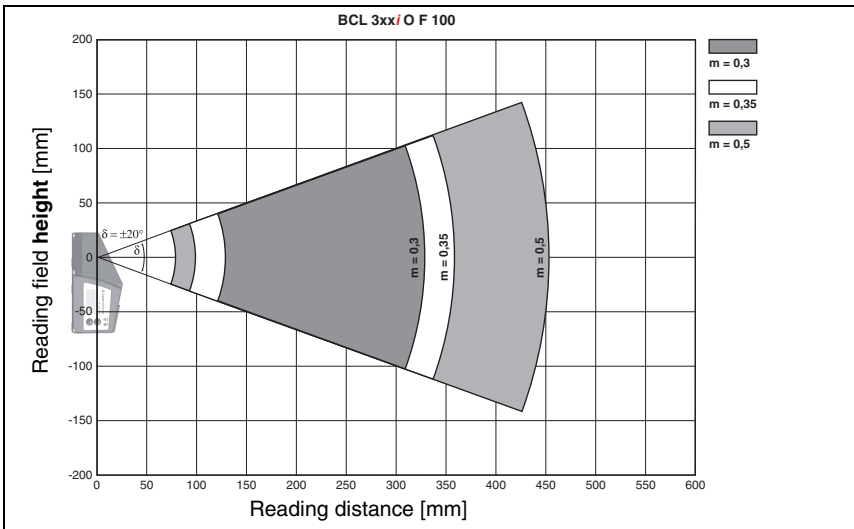

Figure 5.19: Lateral "Low Density" reading field curve for oscillating-mirror scanners

The reading field curves apply for the reading conditions stated in table 5.7.

5.5.10 Ultra Low Density (L) - optics: BCL 348*i* S/R1 L 102 (H)

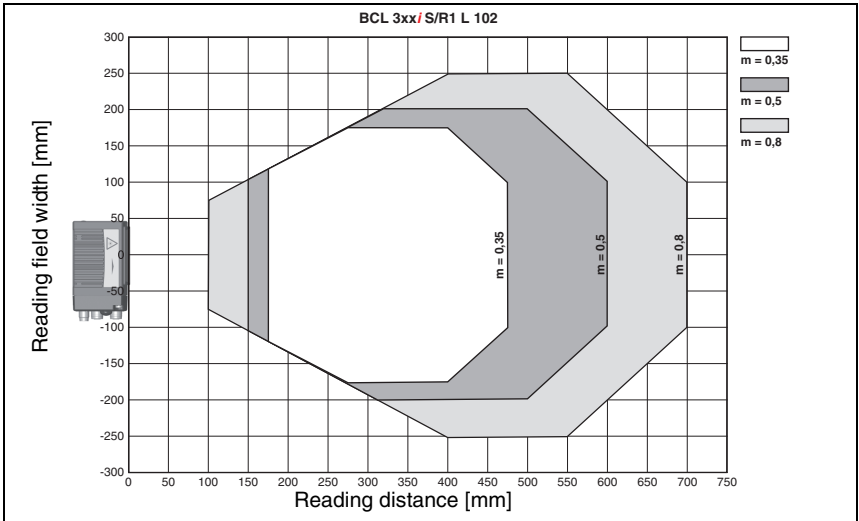

Figure 5.20: "Ultra Low Density" reading field curve for line scanner without deflection mirror

5.5.11 Ultra Low Density (L) - optics: BCL 348*i* S/R1 L 100 (H)

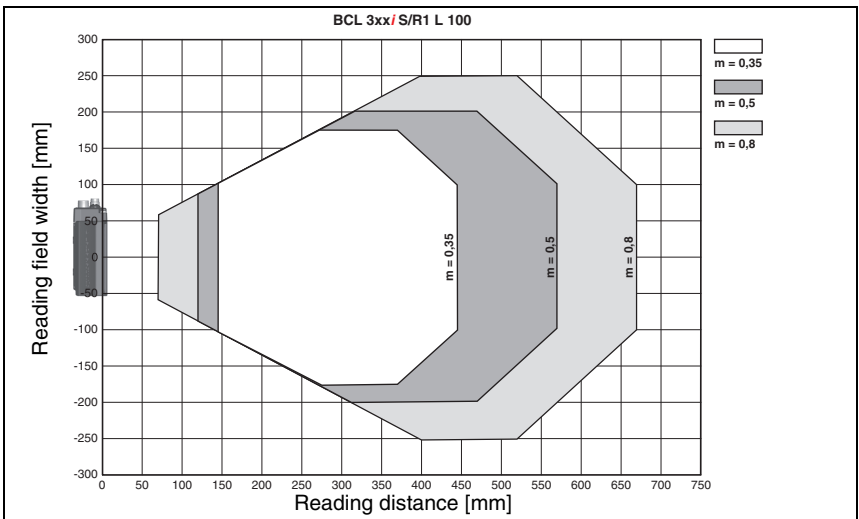

Figure 5.21: "Ultra Low Density" reading field curve for line scanner with deflection mirror

The reading field curves apply for the reading conditions stated in table 5.7.

5.5.12 Ultra Low Density (L) - optics: BCL 348*i* OL 100 (H)

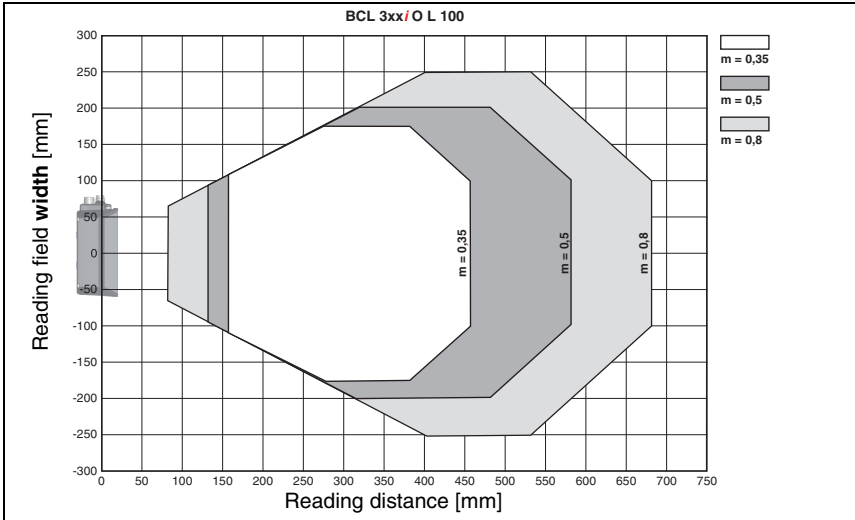

Figure 5.22: "Ultra Low Density" reading field curve for oscillating-mirror scanners

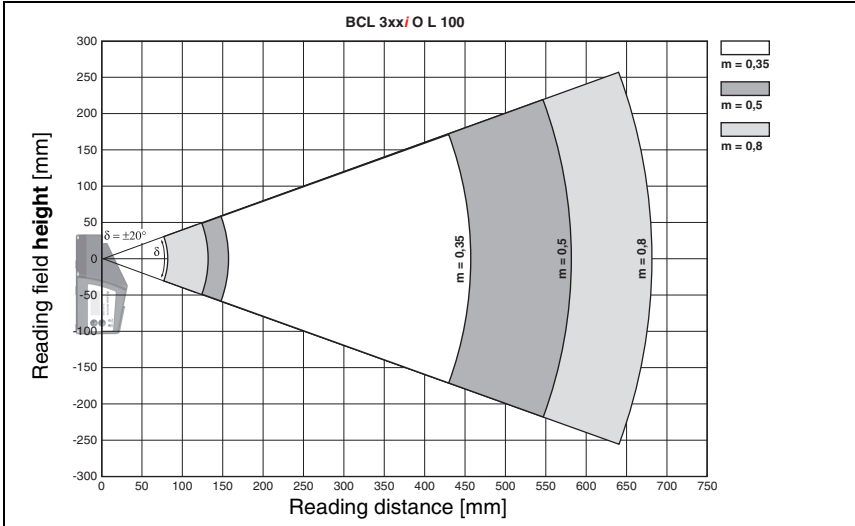

Figure 5.23: Lateral "Ultra Low Density" reading field curve for oscillating-mirror scanners

The reading field curves apply for the reading conditions stated in table 5.7.

6 Installation and mounting

6.1 Storage, transportation



Attention!

When transporting or storing, package the device so that it is protected against collision and humidity. Optimum protection is achieved when using the original packaging. Heed the required environmental conditions specified in the technical data.

Unpacking

- ↳ Check the packaging for any damage. If damage is found, notify the post office or shipping agent as well as the supplier.
- ↳ Check the delivery contents using your order and the delivery papers:
 - Delivered quantity
 - Device type and model as indicated on the name plate
 - Laser warning signs
 - Brief manual

The name plate provides information as to what BCL type your device is. For specific information, please refer to chapter 5.

Name plates of the bar code readers of the BCL 348i series

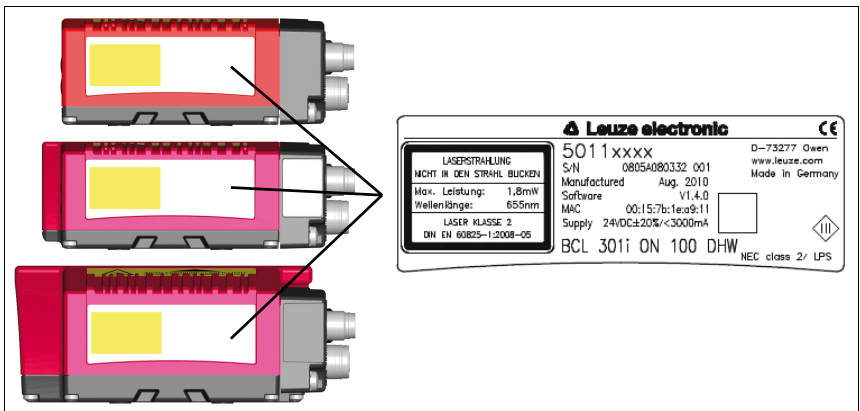

Figure 6.1: Device name plate BCL 348i

- ↳ Save the original packaging for later storage or shipping.



Notice!

All BCL 348i are delivered with a protective cover on the connection side which must be removed before attaching a connection hood.

If you have any questions concerning your shipment, please contact your supplier or your local Leuze electronic sales office.

 Observe the applicable local regulations when disposing of the packaging materials.

6.2 Mounting the BCL 348*i*

The BCL 348*i* bar code readers can be mounted in two different ways:

- Via four or six M4x5 screws on the bottom of the device.
- Via a BT 56 mounting device in the two fastening grooves on the bottom of the device.



Attention!

The BCL 300*i* does not fulfill protection class IP 65 until the connection hood has been screwed on. Minimum tightening torque of the housing connection screws on the connection hood 1.4Nm!

6.2.1 Fastening with M4 x 5 screws

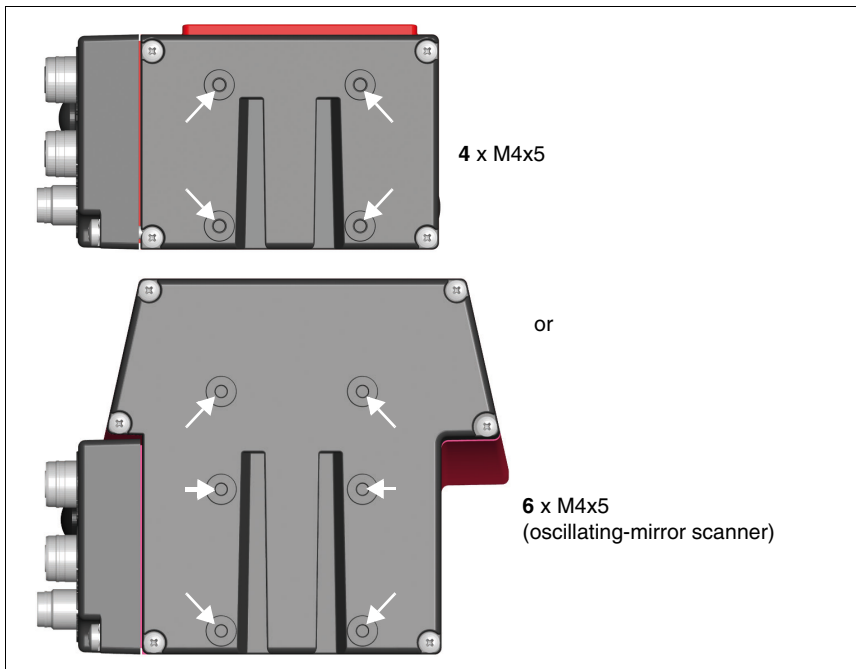

Figure 6.2: Fastening options using M4x5 threaded holes

6.2.2 BT 56 mounting device

The BT 56 mounting device is available for mounting the BCL 348*i* using the fastening grooves. It is designed for rod mounting (Ø 16mm to 20mm). For ordering instructions, please refer to chapter "Type overview and accessories" on page 136.

BT 56 mounting device

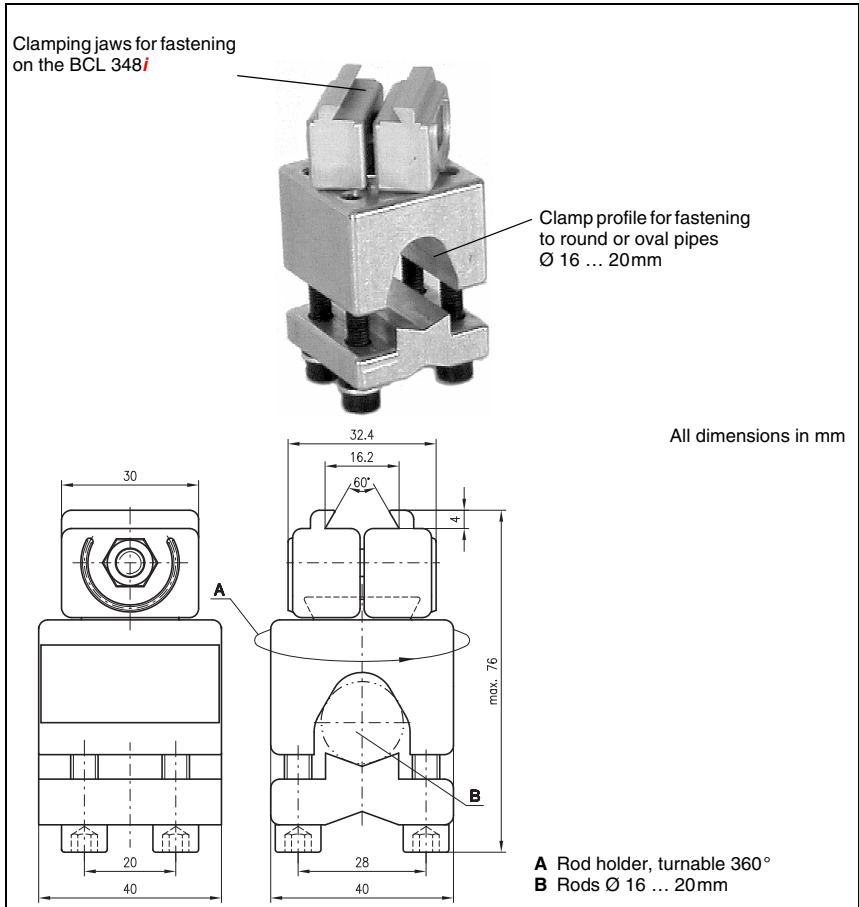

Figure 6.3: BT 56 mounting device

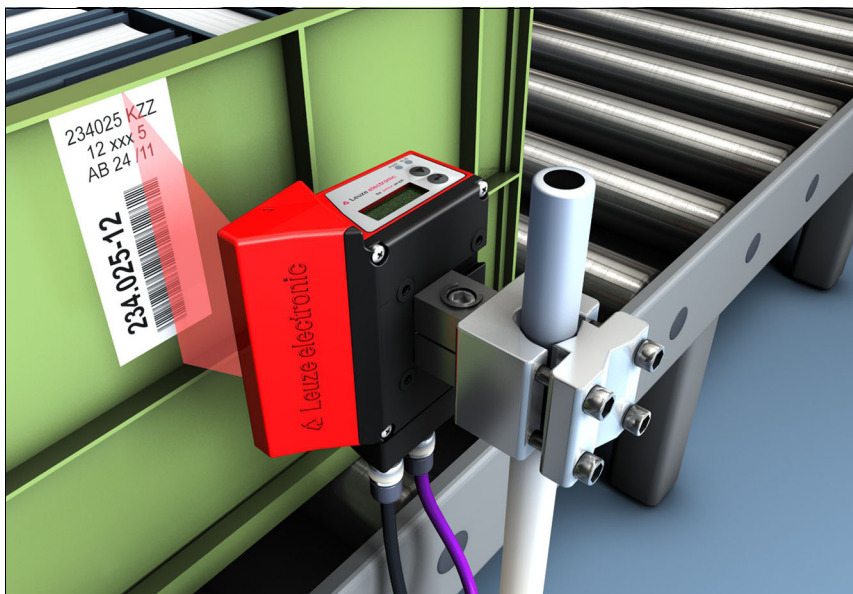

Figure 6.4: Mounting example of BCL 348*i* with BT 56

6.2.3 BT 59 mounting device

The BT 59 mounting device offers you an additional fastening option. For ordering instructions, please refer to chapter "Type overview and accessories" on page 136.

BT 59 mounting device

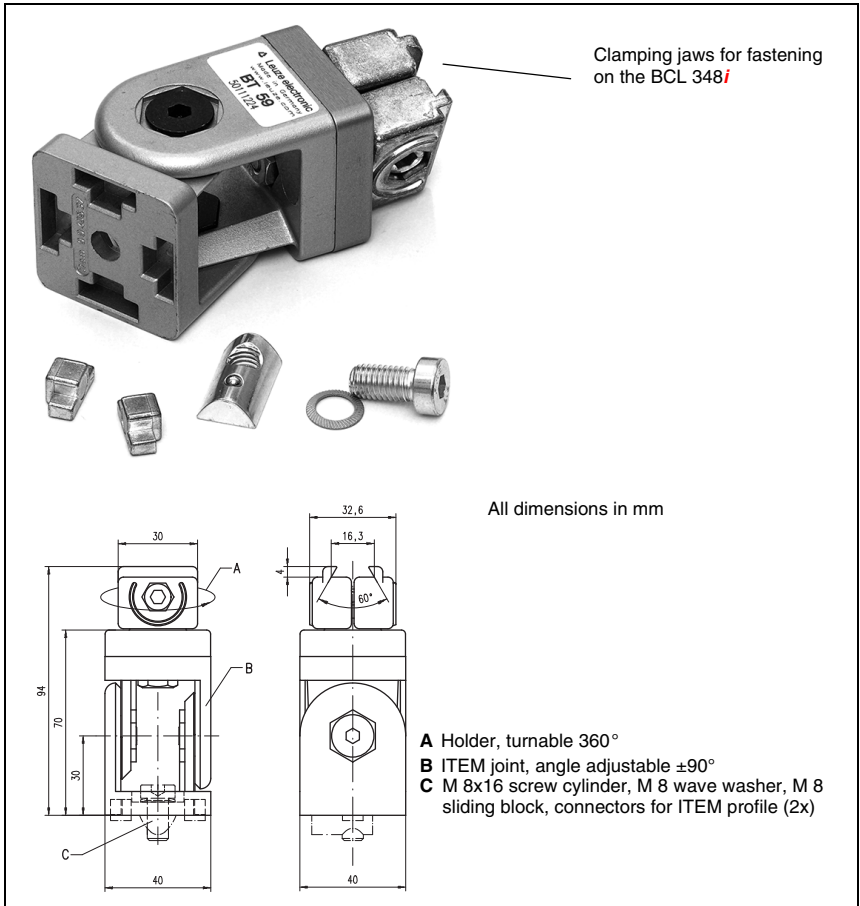

Figure 6.5: BT 59 mounting device



Notice!

When mounting, ensure that the scanning beam is not reflected directly back to the scanner by the label which is being read. For further information, see the notices in chapter 6.3! Please refer to chapter 5.4 for the permissible minimum and maximum distances between the BCL 348*i* and the labels to be read.

6.3 Device arrangement

6.3.1 Selecting a mounting location

In order to select the right mounting location, several factors must be considered:

- Size, orientation, and position tolerance of the bar codes on the objects to be scanned.
- The reading field of the BCL 348*i* in relation to the bar code module width.
- The resulting minimum and maximum reading distance from the respective reading field (see chapter 5.4 "Reading field curves / optical data").
- The permissible cable lengths between the BCL 348*i* and the host system depending on which interface is used.
- The correct time for data output. The BCL 348*i* should be positioned in such a way that, taking into consideration the time required for data processing and the conveyor belt speed, there is sufficient time to e.g. initiate sorting operations on the basis of the read data.
- The display elements such as LEDs or the display should be highly visible.
- For configuring and commissioning with the webConfig tool, the USB interface should be easily accessible.

For specific information, please refer to chapter 6 and chapter 7.



Notice!

*The beam of the BCL 348*i* exits:*

- **parallel** to the **housing base** in the case of the line scanner
- at **105 degrees** from the **housing base** in the case of the deflection mirror
- **perpendicular** to the **housing base** in the case of the oscillating mirror

In each case, the housing base is the black area in figure 6.2. The best read results are obtained when:

- *The BCL 348*i* is mounted in such a way that the scanning beam is incident on the bar code at an angle of inclination greater than $\pm 10^\circ$... 15° to vertical.*
- *The reading distance lies in the middle area of the reading field.*
- *The bar code labels are of good print quality and have good contrast ratios.*
- *You do not use high-gloss labels.*
- *There is no direct sunlight.*

6.3.2 Avoiding total reflection – Line scanner

The bar code label must be positioned at an angle of inclination greater than $\pm 10^\circ \dots 15^\circ$ from vertical in order to avoid total reflection of the laser beam (see figure 6.6)!

Total reflection occurs whenever the laser light of the bar code reader is directly incident on the surface of the bar code at an angle of 90° . The light directly reflected by the bar code may overload the bar code reader and thereby cause non-readings!

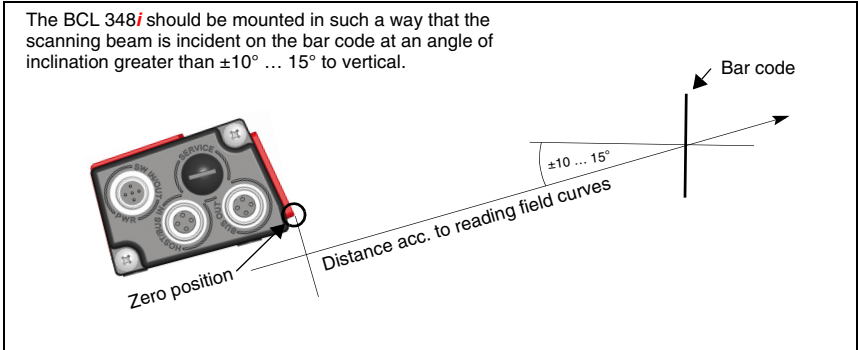

Figure 6.6: Total reflection – line scanner

6.3.3 Avoiding total reflection – deflection mirror scanner

For the BCL 348*i* with **deflection mirror**, the laser beam exits at an angle of 105° to the rear housing wall.

An angle of incidence of 15° of the laser to the label has already been integrated in the deflection mirror so that the BCL 348*i* can be installed parallel to the bar code (rear housing wall).

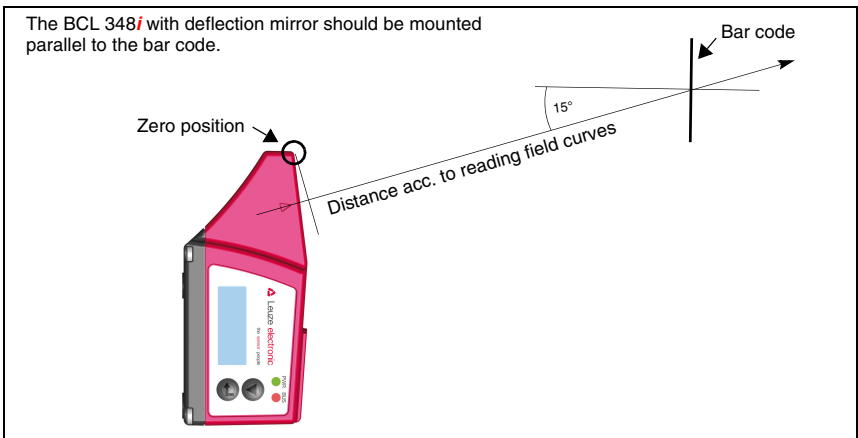

Figure 6.7: Total reflection – line scanner

6.3.4 Avoiding total reflection – oscillating-mirror scanner

For the BCL 348*i* with **oscillating mirror**, the laser beam exits at an angle of **90° to vertical**.

For the BCL 348*i* with **oscillating mirror**, the **swivel range of ±20°** (±12° for devices with heating) **is to be taken into account**.

This means that in order to be on the safe side and to avoid total reflection, the BCL 348*i* with oscillating mirror must be inclined upward or downward 20° ... 30°!



Notice!

Mount the BCL 348*i* with oscillating mirror in such a way that the outlet window of the bar code reader is parallel to the object. This will result in an angle of inclination of approx. 25°.

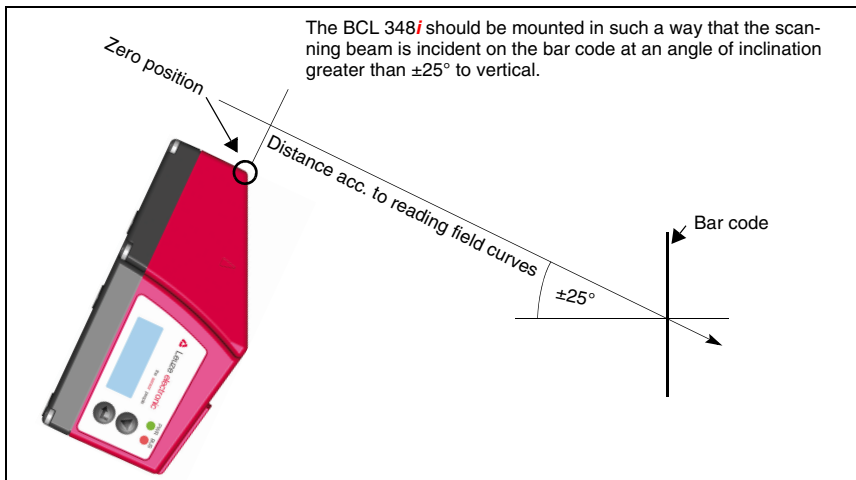

Figure 6.8: Total reflection – BCL 348*i* with oscillating mirror

6.3.5 Mounting location

↳ When selecting a mounting location, pay attention to:

- Maintaining the required environmental conditions (temperature, humidity).
- Possible soiling of the reading window due to liquids, abrasion by boxes, or packaging material residues.
- Lowest possible chance of damage to the BCL 348*i* by mechanical collision or jammed parts.
- Possible extraneous light (no direct sunlight or sunlight reflected by the bar code).

6.3.6 Devices with integrated heating

↳ For devices with integrated heating, also observe the following points:

- Mount the BCL 348*i* in a way which provides maximum thermal isolation, e.g. using rubber-bonded metal.
- Mount in such a way that the device is protected from draft and wind; mount additional shields if necessary.



Notice!

When installing the BCL 348*i* in a protective housing, it must be ensured that the scanning beam can exit the protective housing without obstruction.

6.3.7 Possible reading angles between BCL 348*i* and bar code

The optimum alignment of the BCL 348*i* is accomplished when the scan line scans the code bars almost at a right angle (90°). All reading angles that are possible between the scan line and bar code must be taken account (figure 6.9).

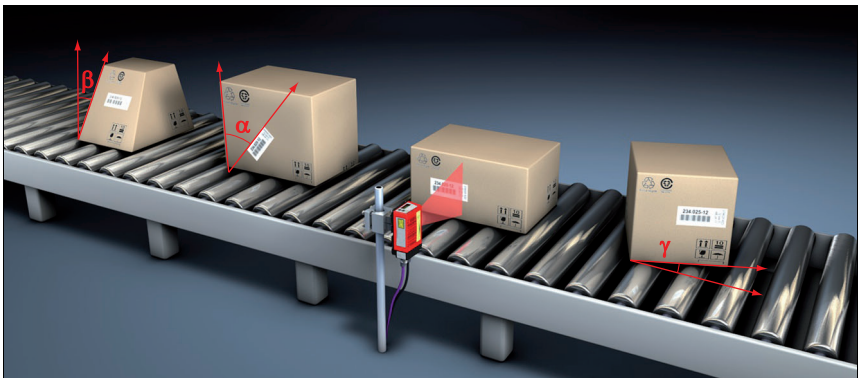

Figure 6.9: Reading angle for the line scanner

- α Tilt
- β Angle of inclination (Pitch)
- γ Skew

In order to avoid total reflection, the skew γ should be greater than 10°.

6.4 Cleaning

- ↳ Clean the glass pane of the BCL 348*i* with a soft cloth after mounting. Remove all packaging remains, e.g. carton fibers or Styrofoam balls. In doing so, avoid leaving fingerprints on the front cover of the BCL 348*i*.

**Attention!**

Do not use aggressive cleaning agents such as thinner or acetone for cleaning the device.

7 Electrical connection

The bar code readers in the BCL 300*i* series feature a modular connection concept with interchangeable connection hoods.

The additional Mini-B type USB interface is used for service purposes.



Notice!

On delivery, the products are provided with a plastic protective cap on the side of the system plug or the system socket.

Additional connection accessories can be found in chapter 13.



Attention!

*The BCL 348*i* does not fulfill protection class IP 65 until the connection hood has been screwed on. Minimum tightening torque of the housing connection screws on the connection hood 1.4Nm!*

Location of the electrical connections

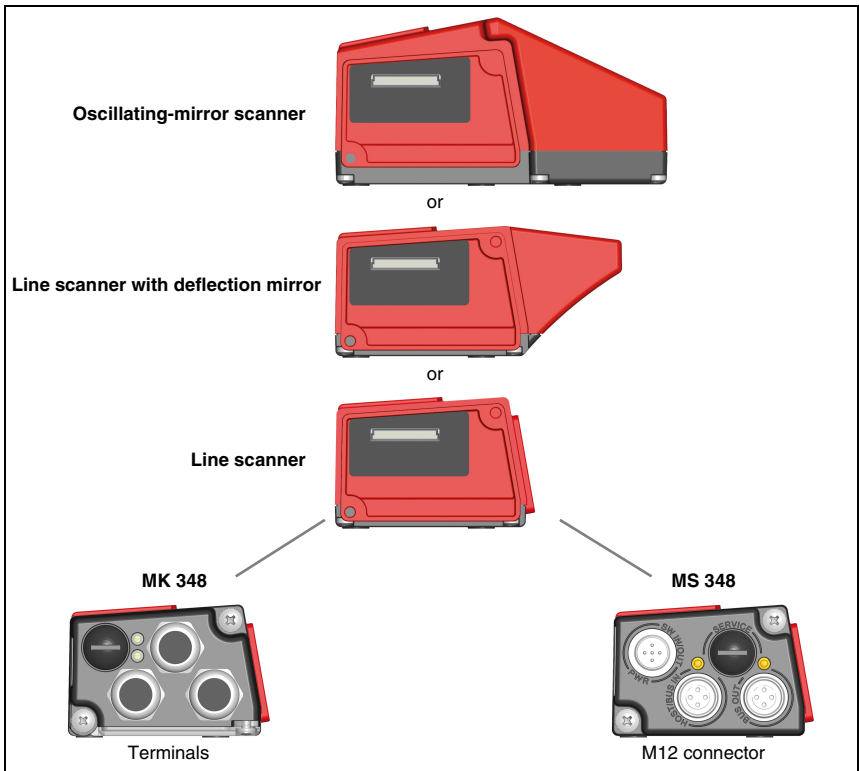

Figure 7.1: Location of the electrical connections

7.1 Safety notices for the electrical connection

**Attention!**

*Do not open the device yourself under any circumstances! There is otherwise a risk of uncontrolled emission of laser radiation from the device. The housing of the BCL 348*i* contains no parts that need to be adjusted or maintained by the user.*

Before connecting the device, be sure that the supply voltage agrees with the value printed on the name plate.

Connection of the device and cleaning must only be carried out by a qualified electrician.

Ensure that the functional earth (FE) is connected correctly. Unimpaired operation is only guaranteed when the functional earth is connected properly.

If faults cannot be corrected, the device should be removed from operation and protected against possible commissioning.

**Attention!**

For UL applications, use is permitted exclusively in Class 2 circuits according to NEC (National Electric Code).



*The bar code readers of the BCL 300*i* series are designed in accordance with safety class III for supply by PELV (protective extra-low voltage).*

**Notice!**

Protection class IP 65 is not fulfilled until connectors or cable lead-throughs are screwed on and caps are installed!

**Attention!**

To ensure protection class IP 65 is fulfilled, the screws of the connection hood are tightened with a tightening torque of 1.4Nm for connecting to the BCL.

7.2 Electrical connection BCL 348*i*

For the electrical connection of the BCL 348*i*, 2 connection variants are available.

The **voltage supply** (18 ... 30VDC) is connected acc. to the connection type selected.

2 freely programmable switching inputs/outputs for individual adaptation to the respective application are also available here. Detailed information on this topic can be found in chapter 7.3.1.

7.2.1 MS 348 hood with 3 integrated M12 connectors

The MS 348 hood with integrated connectors features three M12 connector plugs and a Mini-B type USB socket as a service interface. During device exchange, the device name of the BCL 348*i* does not have to be reassigned in PROFINET; it is saved in the MS 348 and automatically imported for the new device. In doing so, the settings of the old device are automatically transmitted to the new device.



Attention!

If the BCL 348*i* is used in line topology, the PROFINET is interrupted at this place during device exchange.

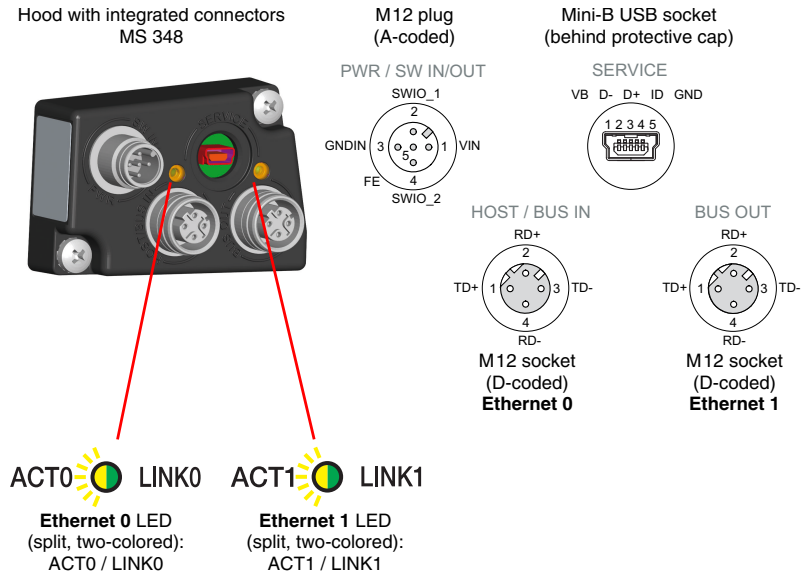

Figure 7.2: BCL 348*i* - MS 348 hood with integrated M12 connectors



Notice!

The shielding connection is done via the M12 connector housing.



Notice!

The integrated parameter memory for the simple replacement of the BCL 348*i* is located in the MS 348. In the integrated parameter memory, both the settings and the PROFINET name are saved and transmitted to a new device.



Notice!

In the case of PROFINET line topology, the network is interrupted when the BCL 348*i* is removed from the MS 348.



Notice!

See chapter 5.3.5 "Dimensioned drawing of MS 3xx hood with integrated connectors / MK 3xx terminal hood" dimensioned drawing on page 51.

7.2.2 MK 348 terminal hood with spring-loaded terminals

The MK 348 terminal hood makes it possible to connect the BCL 348*i* directly and without additional connectors. The MK 348 features three cable lead-throughs in which the shielding connection for the interface cable is also located. A Mini-B type USB socket is used for service purposes. The device name is saved in the MK 348 and is passed to the new device during device exchange. In doing so, the settings are automatically transmitted to the new device.

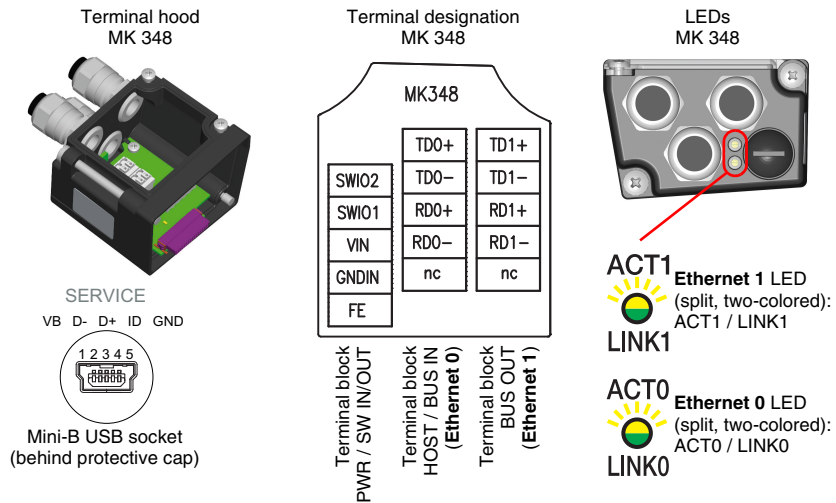

Figure 7.3: BCL 348*i* - MK 348 terminal hood with spring-loaded terminals



Notice!

The integrated parameter memory for simple exchange of the BCL 348*i* is located in the MK 348. In the integrated parameter memory, both the settings and the PROFINET name are saved and transmitted to a new device.



Notice!

In the case of PROFINET line topology, the network is interrupted when the BCL 348*i* is removed from the MK 348.

Cable fabrication and shielding connection

Remove approx. 78mm of the connection cable sheathing. 15mm of sheath of the shielded line must be freely accessible.

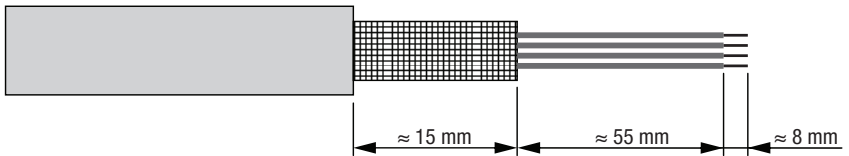

Figure 7.4: Cable fabrication for MK 348 terminal hood

The shield is automatically contacted when the cable is lead into the metal screw fitting and fastened when the cord grip is closed. Then lead the individual wires into the terminals according to the diagram. Wire end sleeves are not necessary.



Notice!

See chapter 5.4 "Reading field curves / optical data" dimensioned drawing on page 52.

7.3 Detailed description of the connections

Described in detail in the following are the individual connections and pin assignments.

7.3.1 PWR / SW IN/OUT - Voltage supply and switching input/outputs 1 and 2

PWR / SW IN/OUT			
	Pin (M12)	Name (terminal)	Remark
 <p>MS 348 PWR / SW IN/OUT</p> <p>M12 plug (A-coded)</p>	1	VIN	Positive supply voltage +18 ... +30VDC
	2	SWIO_1	Configurable switching input / output 1
	3	GNDIN	Negative supply voltage 0VDC
	4	SWIO_2	Configurable switching input / output 2
	5	FE	Functional earth
 <p>MK 348</p> <p>Spring-loaded terminals</p>	Thread	FE	Functional earth (housing)

Table 7.1: Pin assignment PWR / SW IN/OUT

Supply voltage

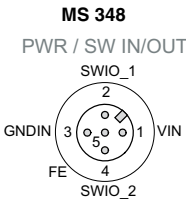
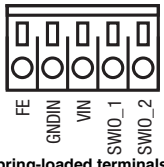

Attention!

For UL applications, use is permitted exclusively in Class 2 circuits according to NEC (National Electric Code).



The bar code readers of the BCL 300*i* ... series are designed in accordance with safety class III for supply by PELV (protective extra-low voltage).

Connecting functional earth FE

⚡ Ensure that the functional earth (FE) is connected correctly. Unimpaired operation is only guaranteed when the functional earth is connected properly. All electrical disturbances (EMC couplings) are discharged via the functional earth connection.

Switching input / output

The bar code readers of the BCL 300*i* series are equipped with two freely programmable, opto-decoupled switching inputs and outputs, **SWIO_1** and **SWIO_2**.

The switching inputs can be used to activate various internal functions of the BCL 348*i* (decoding, autoConfig, ...). The switching outputs can be used to signal the state of the BCL 348*i* and to implement external functions independent of the superior control.



Notice!

The respective function as input or output can be set with the aid of the webConfig configuration tool!

Described in the following is the external wiring for use as a switching input or output; the respective function assignments to the switching inputs/outputs can be found in chapter 10.

Function as switching input

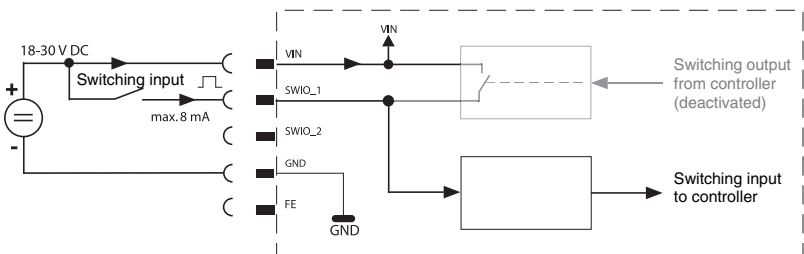

Figure 7.1: Switching input connection diagram SWIO_1 and SWIO_2

If you use a sensor with a standard M12 connector, please note the following:

- Pins 2 and 4 must not be operated as switching outputs if sensors which function as inputs are also connected to these pins.

If, for example, the inverted sensor output is connected to pin 2, and pin 2 of the bar code reader is, at the same time, configured as an output (and not as an input), the switching output malfunctions.



Attention!

The maximum input current must not exceed 8mA!

Function as switching output

Figure 7.2: Switching output connection diagram SWIO_1 / SWIO_2

**Attention!**

Each configured switching output is short-circuit proof! Do not load the respective switching output of the BCL 348*i* with more than 60mA at +18 ... +30 VDC in normal operation!

**Notice!**

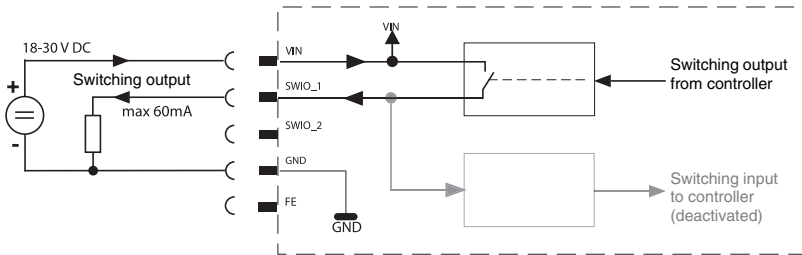
Both switching inputs/outputs SWIO_1 and SWIO_2 are configured by default in such a way that:

- Switching input SWIO_1 activates the reading gate.
- Switching output SWIO_2 switches by default on "No Read."

7.3.2 SERVICE – USB interface (Mini-B type)

SERVICE – USB interface (Mini-B type)			
	Pin (USB Mini-B)	Name	Remark
<p>SERVICE</p> <p>VB D- D+ ID GND</p> 	1	VB	Sense input
	2	D-	Data -
	3	D+	Data +
	4	ID	Not connected
	5	GND	Ground

Table 7.2: Pin assignment SERVICE – Mini-B type USB interface

⚡ Ensure adequate shielding.

The entire connection cable must absolutely be shielded acc. to the USB specifications. Cable length must not exceed 3m.

⚡ Use the Leuze specific **USB service cable** (See chapter 13 "Type overview and accessories") for the connection and use a service PC to configure.



Notice!

IP 65 is achieved only if the connectors and caps are screwed into place.

7.3.3 HOST / BUS IN for BCL 348*i*

The BCL 348*i* makes a PROFINET-IO interface (Ethernet_0) available as host interface.



HOST / BUS IN PROFINET-IO (4-pin socket, D-coded)			
MS 348 HOST / BUS IN	Pin (M12)	Name (terminal)	Remark
 <p>RD0+ 2 TD0+ 1 3 TD0- RD0- 4</p> <p>M12 socket (D-coded)</p> <p>MK 348</p>  <p>n.c. RD- RD+ TD- TD+ Spring-loaded terminals</p>	1	TD0+	Transmit Data +
	2	RD0+	Receive Data +
	3	TD0-	Transmit Data -
	4	RD0-	Receive Data -
	FE via thread	FE via screw fitting	Functional earth (housing)

Table 7.3: Pin assignment HOST / BUS IN BCL 348*i*

↳ For the host connection of the BCL 348*i*, the "KB ET - ... - SA-RJ45" ready-made cables are preferred, see table 13.9 "Bus connection cable for the BCL 348*i*" on page 141.

PROFINET-IO cable assignments

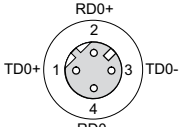
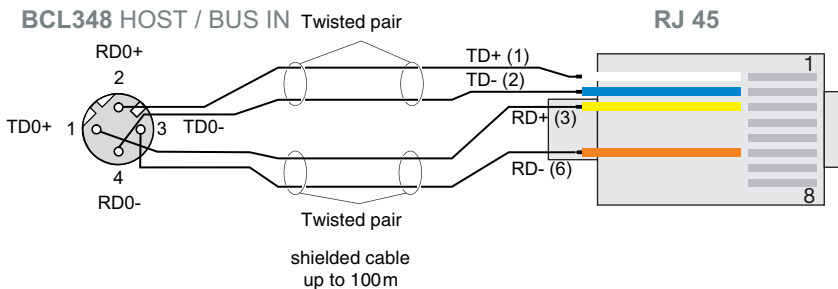

Figure 7.3: HOST / BUS IN cable assignments on RJ-45



Notice for connecting the PROFINET-IO interface!

Ensure adequate shielding. The entire connection cable must be shielded and earthed. The RD+/RD- and TD+/TD- wires must be stranded in pairs. Use CAT 5 cable for the connection.

7.3.4 BUS OUT for the BCL 348*i*

To set up a PROFINET-IO network with other participants with linear topology, the BCL 348*i* makes available another PROFINET-IO RT interface (Ethernet_1). The use of this interface drastically reduces the cabling requirements, as only the first BCL 348*i* requires a direct connection to the switch, via which it can communicate with the host. All other BCL 348*i* are connected in series to the first BCL 348*i*, see figure 7.5.

BUS OUT PROFINET-IO (4-pin socket, D-coded)			
	Pin (M12)	Name (terminal)	Remark
<p>MS 348 BUS OUT</p> <p>RD1+ 2 TD1+ 1 3 TD1- RD1- 4</p> <p>M12 socket (D-coded)</p> <p>MK 348</p> <p>n.c. RD1- RD1+ TD1- TD1+</p> <p>Spring-loaded terminals</p>	1	TD1+	Transmit Data +
	2	RD1+	Receive Data +
	3	TD1-	Transmit Data -
	4	RD1-	Receive Data -
	FE via thread	FE via screw fitting	Functional earth (housing)

Table 7.4: Pin assignment BUS OUT BCL 348*i*

↳ For the connection of two BCL 348*i*, the "KB ET - ... - SSA" ready-made cables are preferred, see table 13.9 "Bus connection cable for the BCL 348*i*" on page 141.

If you use user-configurable cables, note the following:



Notice!

Ensure adequate shielding. The entire connection cable must be shielded and earthed. The signal lines must be stranded in pairs. Use CAT 5 cable for the connection.



Notice!

For the BCL 348*i* as standalone device or as the last participant in a linear topology, termination on the BUS OUT socket is not mandatory!

7.4 PROFINET-IO topologies

The BCL 348*i* can be operated as a single device (standalone) with individual device name in a PROFINET-IO star topology. The PLC must communicate this device name to the participant during the "device naming" (see section "Step 5 – Configuration of the device name - naming the device" on page 103).

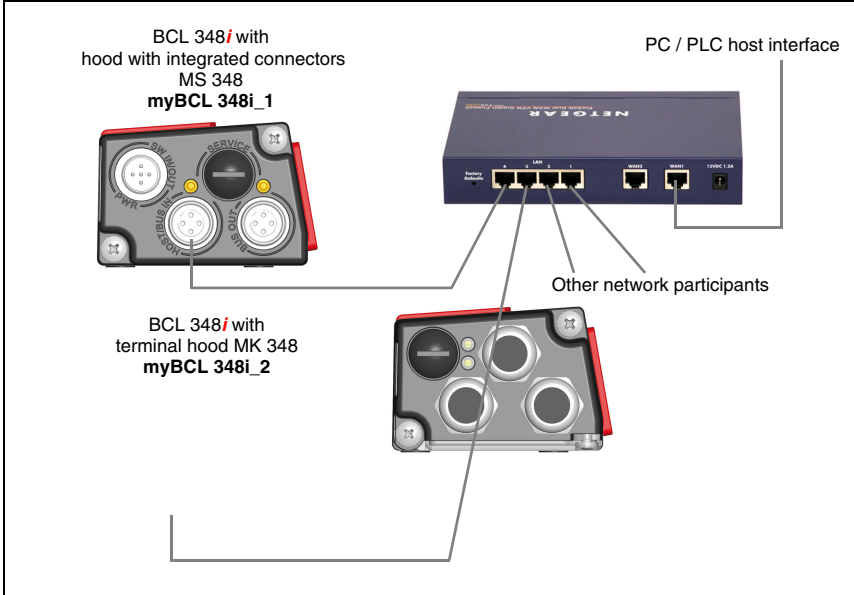

Figure 7.4: PROFINET-IO in a star topology

The innovative further development of the BCL 348*i* with integrated switch functionality offers the option of networking multiple bar code readers of type BCL 348*i* with one another. In addition to the classic "star topology", a "linear topology" is thus also possible.

This makes wiring the network easy and inexpensive as participants are connected to one another in parallel.

The maximum length of a segment (connection from one participant to the next) is limited to 100m.

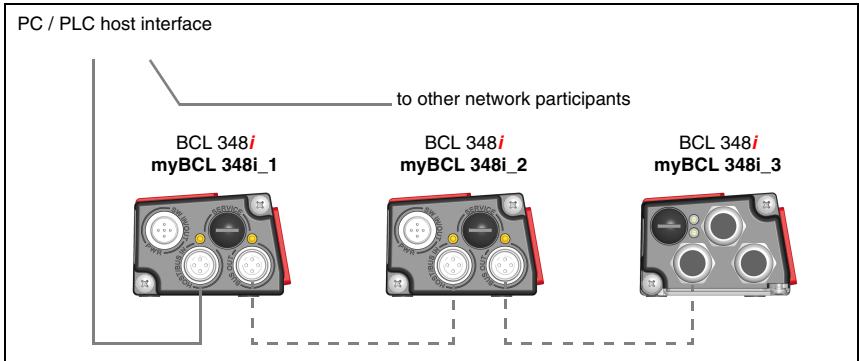

Figure 7.5: PROFINET-IO in a line topology

Up to 254 bar code readers can be networked. They must all be located in the same subnet. To do this, the individual "device name" is assigned to each participating BCL 348*i* through "device naming", using the control's configuration tool. For specific information, please refer to section "Step 5 – Configuration of the device name - naming the device" on page 103. Information on the necessary configuration steps can be found in chapter 10.

7.4.1 PROFINET-IO wiring

A Cat. 5 Ethernet cable should be used for wiring.

For the connection technology transition from M12 to RJ45, a "KDS ET M12 / RJ 45 W - 4P" adapter is available that lets you connect standard network cables.

If no standard network cables are to be used (e.g. due to lacking IP... protection class), you can use the "KB ET - ... - SA" user-configurable cable on the BCL 348*i*, see table 13.9 "Bus connection cable for the BCL 348i" on page 141.

The individual BCL 348*i* devices in a linear topology are connected with the "KB ET - ... - SSA" cable, see table 13.9 "Bus connection cable for the BCL 348i" on page 141.

For unavailable cable lengths, you can configure your cables yourself. When doing so, make certain that you connect **TD+** on the M12 connector with **RD+** on the RJ-45 connector and **TD-** on the M12 connector with **RD-** on the RJ-45 connector, respectively, etc.



Notice!

Use the recommended connectors / sockets or the ready-made cables (See chapter 13 "Type overview and accessories").

7.5 Cable lengths and shielding

↳ Observe the following maximum cable lengths and shielding types:

Connection	Interface	Max. cable length	Shielding
BCL – service	USB	3m	shielding absolutely necessary acc. to USB specifications
BCL – host	PROFINET-IO RT	100m	absolutely required, shielded
Network from the first BCL to the last BCL	PROFINET-IO RT	the maximum segment length must not exceed 100m for 100Base-TX Twisted Pair (min. Cat. 5)	absolutely required, shielded
BCL – power supply unit		30m	not necessary
Switching input		10m	not necessary
Switching output		10m	not necessary

Table 7.5: Cable lengths and shielding

8 Display elements and display

The BCL 348*i* is available optionally with display, two control buttons and LEDs or with only two LEDs as display elements.

8.1 LED indicators BCL 348*i*



Figure 8.1: BCL 348*i* - LED indicators

Two multicolor LEDs are used as the primary display instrument. LED functions:

PWR LED

PWR



off

Device OFF

- no supply voltage

PWR



flashes green

Device ok, initialization phase

- no bar code reading possible
 - voltage connected
 - self test running
 - initialization running

PWR



green continuous light

Device ok

- bar code reading possible
 - self test successfully finished
 - device monitoring active

PWR



green, briefly off - on

Good read, successful reading

- bar code(s) successfully read



green, briefly off - briefly red - on

No read, reading not successful

- bar code(s) not read



orange continuous light

Service mode

- bar code reading possible
- configuration via the USB service interface
- no data on the host interface



flashes red

Warning set

- bar code reading possible
- temporary operating fault



red continuous light

Device error / parameter enable

- no bar code reading possible

BUS LED



off

No supply voltage

- no communication possible
- PROFINET-IO communication not initialized or inactive



flashes green

Initialization

- of the BCL 348*i*, establishing communication



green continuous light

Operation ok

- network operation ok
- connection and communication to IO Controller (PLC) established ("data exchange")



flashes red

Communication error

- Bus error
- parameterization or configuration failed ("parameter failure")
- IO error
- no data exchange



red continuous light

Network error

8.2 MS 348/MK 348 LED indicators

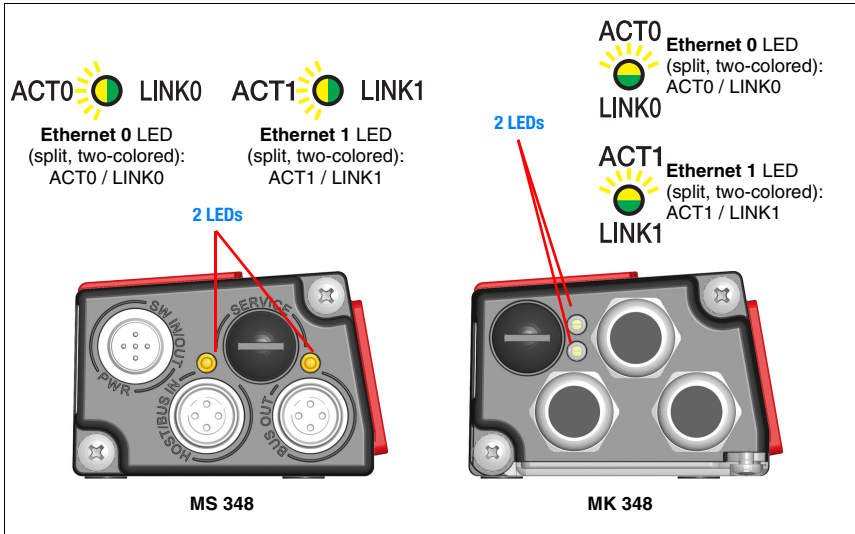

Figure 8.2: MS 348/MK 348 - LED indicators

As a status display for the two PROFINET-IO connections, **Ethernet_0** and **Ethernet_1**, there are two split two-colored LEDs each in the MS 348 and MK 348:

LED ACT0 / LINK0 (on the MS 348/MK 348/)

	<p>green continuous light yellow flickering light</p>	<p>Ethernet connected (LINK) Data communication (ACT)</p>
---	---	---

LED ACT1 / LINK1 (on the MS 348/MK 348/)

	<p>green continuous light yellow flickering light</p>	<p>Ethernet connected (LINK) Data communication (ACT)</p>
---	---	---

8.3 Display BCL 348*i*



Figure 8.3: BCL 348*i* - Display



Notice!

The function of the LEDs is identical for the devices with and without display.

The optional display of the BCL 348*i* has the following features:

- Monochromatic with background lighting (blue/white)
- Double line, 128 x 32 pixels
- Display language: English

The display is only used as a **display element**. Two buttons can control which values are displayed. In doing so, the upper line displays the selected function and the lower line displays the result.

The background lighting is activated by the push of any button and automatically deactivated after a defined point in time:

Display functions

The following functions can be displayed and activated:

- `Reading result` = result of reading process
- `Decodequality` = quality of decoding process
- `BCL Info` = device status/error code
- `I/O Status` = status of the in/output
- `BCL Address` = Device name of the BCL 348*i* in PROFINET-IO
- `Adjustmode` = alignment mode
- `Version` = software and hardware version

After the voltage is switched off/on, `reading result` is always displayed.

The display is controlled via the two control buttons:



ENTER

Activate/deactivate the display change function







Down

Scroll through functions (downwards)

Example:

Representation of the `BUS status` on the display:

1. Press button : display flashes
2. Press button : display changes from read result to decoding quality
3. Press button : display changes from decoding quality to device status
4. Press button : display changes from device status to BUS status
5. Press button : bus status is displayed, display stops flashing.

Description of the display functions

```
Reading result
88776655
```

- 1st line: **read result** display function
- 2nd line: code content of the bar code, e.g. **88776655**

```
Decoding quality
84
```

- 1st line: **decoding quality** display function
- 2nd line: decoding quality in percent, e.g. **84%**

```
BCL info
Error code 3201
```

- 1st line: **device status** display function
- 2nd line: error code, e.g. **Error code 3201**

```
I/O status
In = 0 Out = 1
```

- 1st line: input/output **state** display function
- 2nd line: state: 0 =inactive, 1 = active, e.g. **In=0, Out=1**

```
BCL address
FRITZ
```

- 1st line: display function
- 2nd line: device name in PROFINET-IO, e.g. **FRITZ**

```
Adjust mode
73
```

- 1st line: **alignment mode** display function
- 2nd line: decoding quality in percent, e.g. **73%**

```
Version
SW:xxxxx HW:xxx
```

- 1st line: **version** display function
- 2nd line: software and hardware version of the device

9 Leuze webConfig tool

With the **Leuze webConfig tool**, an operating system independent, web-technology based, graphical user interface is available for configuring bar code readers of the **BCL 300i** series.

Through the use of HTTP as communication protocol and by using only standard technologies on the client side (HTML, JavaScript and AJAX), which are supported by all commonly used, modern browsers (e.g. **Mozilla Firefox** beginning with Version 3.0 or **Internet Explorer** beginning with Version 8.0), it is possible to operate the **Leuze webConfig tool** on any internet-ready PC.



Notice!

The webConfig tool is offered in 5 languages:

- German
- English
- French
- Italian
- Spanish

9.1 Connecting the SERVICE USB interface

The SERVICE USB interface of the BCL 348i is connected via the PC -side USB interface by means of a standard USB cable, with 1 type A connector and 1 Mini-B connector.

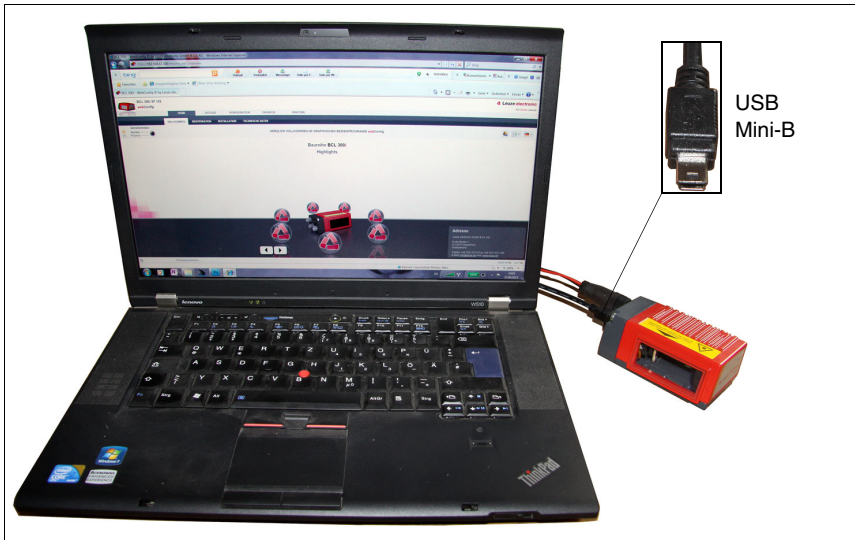

Figure 9.1: Connecting the SERVICE USB interface

9.2 Installing the required software

9.2.1 System requirements

Operating system:	Windows 2000 Windows XP (Home Edition, Professional) Windows Vista Windows 7
Computer:	PC with USB interface version 1.1 or higher
Graphics card:	min. 1024 x 768 pixels or higher resolution
Required hard-disk capacity:	approx. 10MB

**Notice!**

Updating the operating system and the browser regularly and installing the current Windows service packs is recommended.

9.2.2 Installing the USB driver

**Notice!**

*If you have already installed a USB driver for a BCL 5xx*i* on your computer, you don't have to install the USB driver for the BCL 348*i*. In this case, you can also start the webConfig tool of the BCL 348*i* by double-clicking on the BCL 5xx*i* icon.*

In order for the BCL 348*i* to be automatically detected by the connected PC, the **USB driver** must be installed **once** on your PC. To do this, you must have **administrator privileges**.

Please proceed according to the following steps:

- ↳ Start your PC with administrator privileges and log on.
- ↳ Load the CD included in the delivery contents of your BCL 348*i* in the CD drive and start the "setup.exe" program.
- ↳ Alternatively, you can also download the setup program from the internet at www.leuze.com.
- ↳ Follow the instructions provided by the setup program.

Upon successful installation of the USB driver, an  icon with the name **Leuze Web Config** automatically appears on the desktop.

**Notice!**

If the installation failed, contact your network administrator: The settings of the firewall used may need to be adjusted.

9.3 Starting the webConfig tool

To start the **webConfig tool**, click the  icon with the name **Leuze Web Config** located on the desktop. Make certain that the BCL 348*i* is connected to the PC via the USB interface and that voltage is connected.



Notice!

*If you have already installed a USB driver for a BCL 5xx*i* on your computer, you can also start the webConfig tool of the BCL 348*i* by double-clicking on the BCL 5xx*i* icon.*

Alternatively, you can start the webConfig tool by starting the browser installed on your PC and entering the following IP address: **192.168.61.100**

This is the default Leuze maintenance address for communication with bar code readers of the BCL 300*i* and BCL 500*i* series.

In both cases, the following start page appears on your PC.



Figure 9.2: The start page of the webConfig tool



Notice!

*The webConfig tool is completely contained in the firmware of the BCL 348*i*. Depending on firmware version, the start page may vary from that shown above.*

The individual parameters are – where useful – graphically displayed in order to better illustrate the meaning of the what are often perceived as abstract parameters.

The result is an easy-to-use and practically-oriented user interface!

9.4 Short description of the webConfig tool

The webConfig tool has 5 main menus:

- **Home**
with information on the connected BCL 348*i* as well as on installation. This information corresponds to the information in this handbook.
- **Alignment**
for manually starting read processes and for aligning the bar code reader. The results of the read processes are displayed immediately. As a result, this menu item can be used to determine the optimum installation location.
- **Configuration**
for adjusting decoding, for data formatting and output, switching inputs/outputs, communication parameters and interfaces, etc. ...
- **Diagnostics**
for event logging of warnings and errors.
- **Maintenance**
for updating the firmware.

The user interface of the webConfig tool is largely self-explanatory.

9.4.1 Module overview in the Configuration menu

The adjustable parameters of the BCL 348*i* are clustered in modules in the Configuration menu.

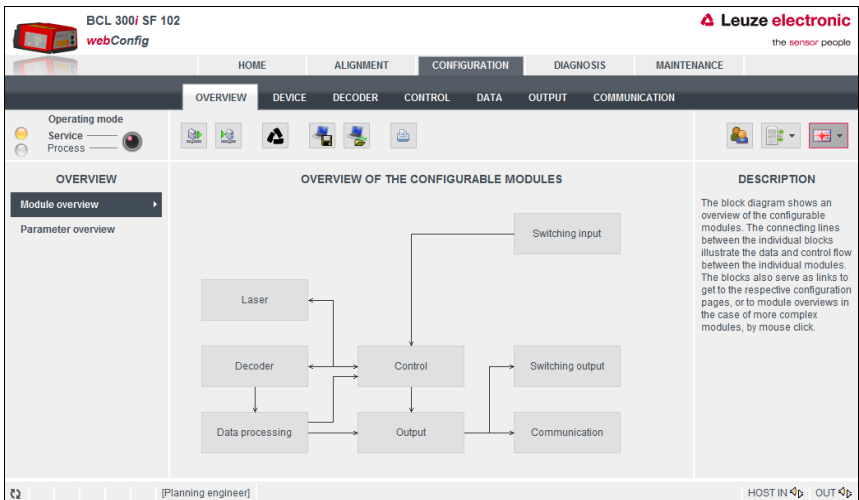

Figure 9.3: Module overview in the webConfig tool

**Notice!**

The webConfig tool is completely contained in the firmware of the BCL 348*i*. Depending on firmware version, the module overview may vary from that shown above.

The individual modules and their relationships to one another are graphically displayed in the module overview. The display is context sensitive, i.e. click a module to directly access the corresponding submenu.

Overview of the configurable modules

- **Device:**
Configuration of the **switching inputs and outputs**
- **Decoder:**
Configuration of the decoder table, such as **code type, number of digits**, etc.
- **Control:**
Configuration of **activation and deactivation**, e.g. **auto-activation, AutoReflAct**, etc.
- **Data:**
Configuration of **code content**, such as **filtering, segmentation of bar code data**, etc.
- **Output:**
Configuration of **data output, header, trailer, reference code**, etc.
- **Communication**
Configuration of the **host interface** and the **service interface**
- **Oscillating mirror:**
Configuration of the **oscillating mirror settings**

**Notice!**

On the right side of the user interface of the webConfig tool, you will find a description of the individual modules and functions as a help text in the **Information** area.

The webConfig tool is available for all bar code readers of the BCL 300*i* series. Because configuration of the BCL 348*i* PROFINET-IO device is performed via the PROFINET-IO Controller, the module overview shown in the webConfig tool is, in this case, used only for displaying and checking the configured parameters.

The current configuration of your BCL 348*i* is loaded upon startup of the webConfig tool. If you change the configuration via the control while the webConfig tool is running, you can use the  "Load parameter from device" button after making the changes to update the display in the webConfig tool. This button appears in the upper left in the center window area in all submenus of the Configuration main menu.

10 Commissioning and configuration



Attention Laser!

Observe the safety notices in chapter 2!

10.1 General information on the PROFINET-IO implementation of the BCL 348*i*

10.1.1 PROFINET-IO communication profile

The **communication profile** defines how participants serially transmit their data via the transmission medium.

The **PROFINET-IO** communication profile is designed for efficient data exchange on the field level. The data exchange with the devices is mainly **cyclical**. For the configuration, operation, monitoring and alarm handling, however, **acyclic** communication services are also used.

Depending on the communication requirements, PROFINET-IO offers suitable protocols and transfer methods:

- **Real Time communication (RT)** via prioritized Ethernet frames for
 - Cyclical process data (I/O data stored in the I/O area of the control)
 - Alarms
 - Clock synchronization
 - Neighborhood information
 - Address assignment/address resolution via DCP

- **TCP/UDP/IP communication** via standard Ethernet TCP/UDP/IP frames for
 - Establishing communication and
 - Acyclic data exchange, and also for the transfer of various information types such as:
 - Parameters for the configuration of the modules during the establishment of the communication
 - I&M data (Identification & Maintenance functions)
 - Reading diagnostic information
 - Reading I/O data
 - Writing device data

10.1.2 Conformance Classes

PROFINET-IO devices are categorized into conformance classes to simplify the evaluation and selection of the devices for the users. The BCL 348*i* can use an existing Ethernet network infrastructure and corresponds to Conformance Class B (CC-B). Thus, it supports the following features:

- Cyclical RT communication
- Acyclic TCP/IP communication
- Alarms/diagnostics
- Automatic address assignment
- I&M 0 functionality
- Neighborhood detection basic functionality
- FAST Ethernet 100 Base-TX/FX
- Convenient device exchange without engineering tools
- SNMP support

10.2 Measures to be performed prior to the initial commissioning

- ↳ Before commissioning, familiarize yourself with the operation and configuration of the BCL 348*i*.
- ↳ Before connecting the supply voltage, recheck all connections and ensure that they have been properly made.

MS 348 hood with 3 integrated M12 connectors

Hood with integrated connectors
MS 348

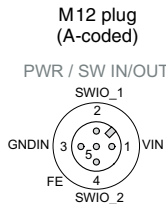

Mini-B USB socket (behind protective cap)

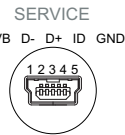

HOST / BUS IN

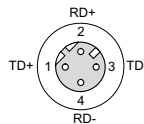

M12 socket (D-coded)
Ethernet 0

BUS OUT

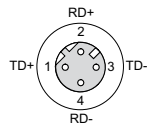

M12 socket (D-coded)
Ethernet 1

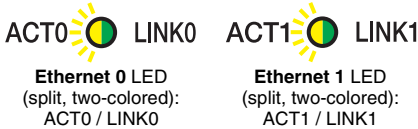

Figure 10.1: BCL 348*i* - MS 348 hood with integrated M12 connectors

MK 348 terminal hood with spring-loaded terminals

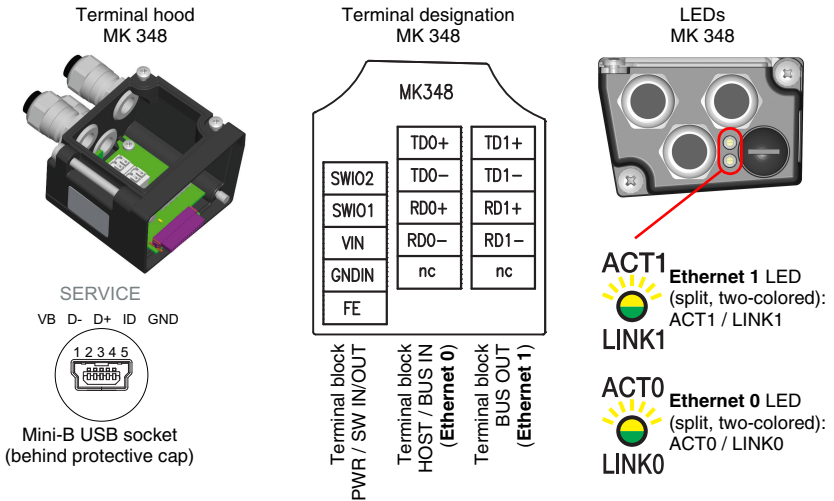

Figure 10.2: BCL 348*i* - MK 348 terminal hood with spring-loaded terminals

⚡ Check the applied voltage. It must be in the range between +18V ... 30VDC.

Connecting functional earth FE

⚡ Ensure that the functional earth (FE) is connected correctly.

Unimpaired operation is only guaranteed when the functional earth is connected properly. All electrical disturbances (EMC couplings) are discharged via the functional earth connection.

10.3 Starting the device

↳ Connect the supply voltage +18 ... 30VDC (typ. +24VDC); the BCL 348*i* starts up and the bar code reading window appears on the display:

First, you need to assign its individual device name to the BCL 348*i*.

10.4 Configuration steps for a Siemens Simatic S7 control

The following steps are necessary for commissioning with a Siemens S7 control:

1. Preparing the control system (S7 PLC)
2. Installing the GSD file
3. Hardware configuration of the S7 PLC
4. Transfer of the PROFINET-IO configuration to the IO Controller (S7 PLC)
5. Device naming
 - Configuration of the device name
 - Device naming
 - Assignment of the device names to the configured IO devices (Figure 10.3...)
 - Assignment of MAC address - IP address -individual device name (Figure 10.4)
6. Check device name

10.4.1 Step 1 – Preparing the control system (S7 PLC)

The first step involves the assignment of an IP address to the IO Controller (PLC - S7) and the preparation of the control for consistent data transmission.



Notice!

If an S7 control is used, you need to ensure that Simatic-Manager Version 5.4 + service pack 5 (V5.4+SP5) or higher is used.

10.4.2 Step 2 – Installation of the GSD file

For the subsequent configuration of the IO devices, e.g., BCL 348*i*, the corresponding GSD file must be loaded first.

General information on the GSD file

The term GSD stands for the textual description of a PROFINET-IO device model.

For the description of the more complex PROFINET-IO device model, the XML-based GSDML (Generic Station Description Markup Language) was introduced.

In the following, the terms "GSD" or "GSD file" always refer to the GSDML-based format.

The GSDML file can support an arbitrary number of languages in one file. Every GSDML file contains a version of the BCL 348*i* device model. This is also reflected in the file name.

File name structure

The file name of the GSD file is constructed according to the following rule:

GSDML-[GSDML schema version]-Leuze-BCL348i-[date].xml

Explanation:

- GSDML schema version:
Version identifier of the GSDML schema version used, e.g., V2.2.
- Date:
Release date of the GSD file in the format `yyyymmdd`.
This date also stands for the release date of the file.

Example:

GSDML-V2.2-Leuze-BCL348i-20090503.xml

You can find the GSD file at

www.leuze.com -> Download -> identify -> Stationary and hand-held bar code readers.

All data in modules required for operating the **BCL 348*i*** is described in this file. These are input and output data and device parameters for the functioning of the **BCL 348*i*** and the definition of the control and status bits.

If parameters are changed, e.g., in the project tool, these changes are stored on the PLC side in the project, not in the GSD file. The GSD file is a certified and integral part of the device and must not be changed manually. The file is not changed by the system either.

The functionality of the **BCL 348*i*** is defined via GSD parameter sets. The parameters and their functions are structured in the GSD file using module. A user-specific configuration tool is used during PLC program creation to integrate the required modules and configure them appropriately for their respective use. During operation of the **BCL 348*i*** on the PROFINET-IO, all parameters are set to default values. If these parameters are not changed by the user, the device functions with the default settings delivered by Leuze electronic.

For the default settings of the **BCL 348*i***, please refer to the following module descriptions.

10.4.3 Step 3 – Hardware configuration of the S7 PLC: Configuration

For the configuration of the PROFINET-IO system using the HW Config of the SIMATIC Manager, insert the BCL 348*i* into your project. An IP address is now assigned to a unique "device name".

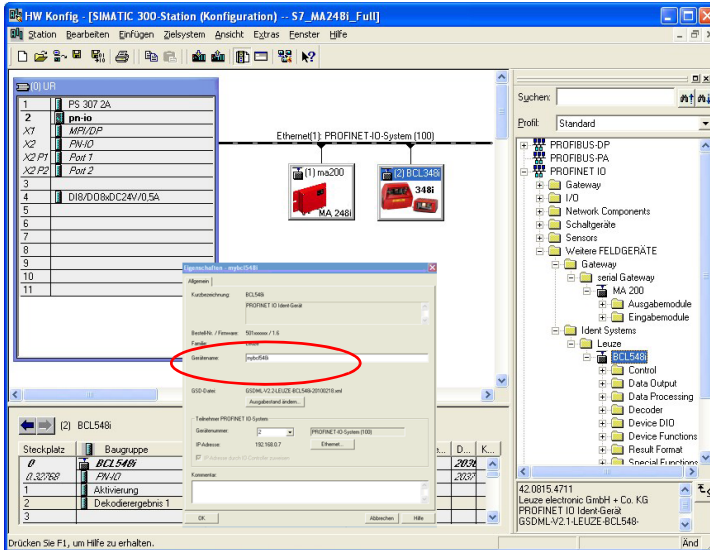

Figure 10.3: Assignment of the device names to IP addresses

10.4.4 Step 4 – Transfer of the configuration to the IO Controller (S7 PLC)

After the correct transfer to the IO Controller (S7 PLC), the PLC automatically carries out the following activities:

- Check device names
- Assignment of the IP addresses that were configured in the HW Config to the IO devices
- Establishment of a connection between the IO Controller and configured IO devices
- Cyclical data exchange



Notice!

Participants that have not been "named" cannot be contacted yet at this point in time!

10.4.5 Step 5 – Configuration of the device name - naming the device

The PROFINET-IO device has a unique MAC address that is part of the factory settings. You can find this address on the name plate of the bar code reader.

This information is used to assign a unique, plant-specific device name ("NameOfStation") to the device via the "Discovery and Configuration Protocol (DCP)".

The PROFINET-IO also uses the "Discovery and Configuration Protocol" (DCP) for the IP address assignment during each system boot-up if the IO device is located in the same subnet.



Notice!

All BCL 348i participants in a PROFINET-IO network must be located in the same subnet!

Device naming

PROFINET-IO defines the "naming of the device" as the creation of a name-based relationship for a PROFINET-IO device.

Assigning the device names to the configured IO devices

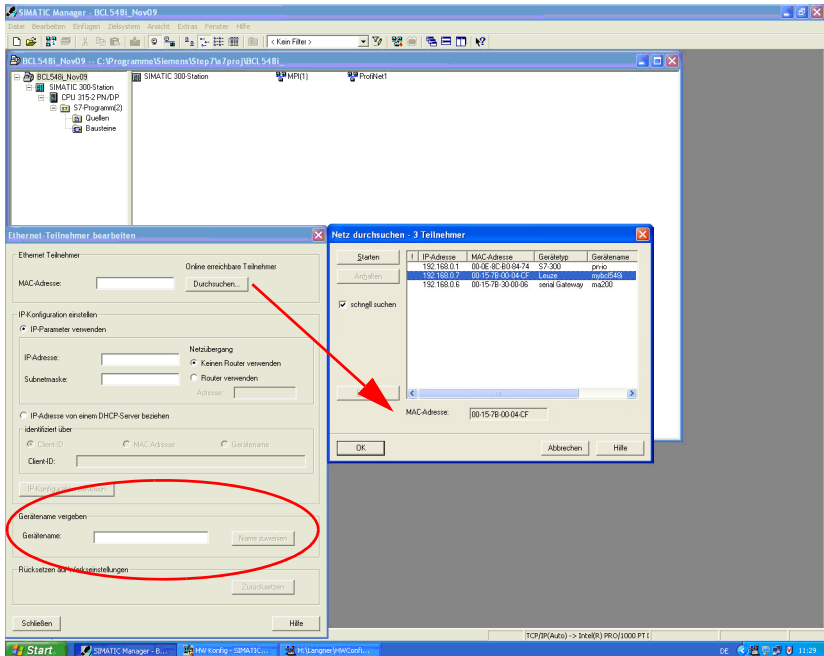

Figure 10.4: Assigning the device names to the configured IO devices

At this point, you can select the respective bar code scanner BCL 348*i* for the "device naming" based on its MAC address. The unique "device name" (which must match the participant in the HW Config) is then assigned to this participant.



Notice!

Multiple BCL 348*i* can be distinguished by the MAC addresses displayed. The MAC address may be found on the name plate of the respective bar code scanner.

MAC address - IP address -individual device name

At this point, please assign an IP address (suggested by the PLC), a subnet mask and, if required, a router address, and assign this data to the named participant ("device name").

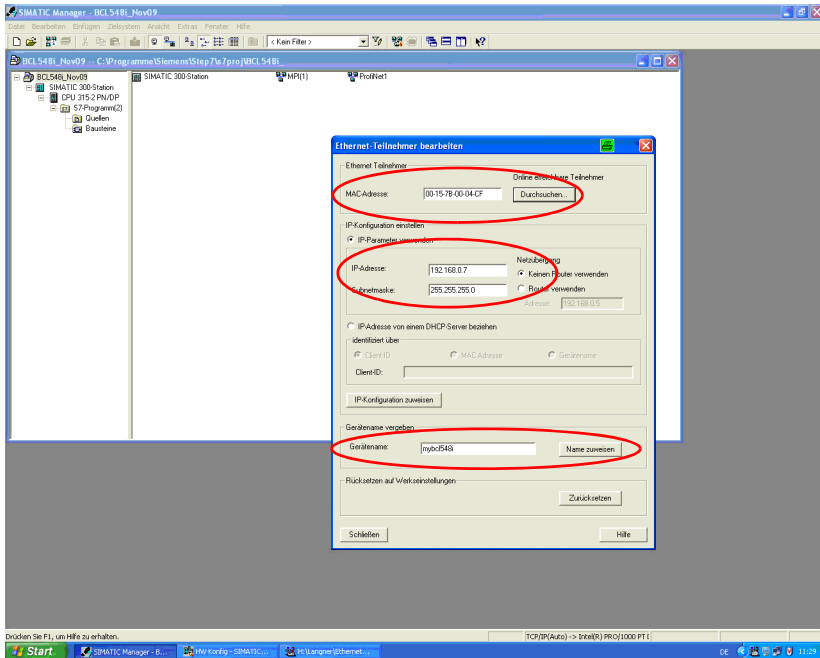

Figure 10.5: MAC address - IP address -individual device name

From now on, and when programming, only the unique "device name" (max. 255 characters) is used.

10.4.6 Step 6 – Check device names

After completing the configuration phase, it is sensible to recheck the "device names" that have been assigned. Please ensure that these names are unique and that all participants are located in the same subnet.

10.4.7 Manually setting the IP address

This chapter is only of interest if an additional IP address independent of the device name is to be established for an additional communication channel, e.g. TCP/ IP.

If your system does not include a DHCP server or if the IP addresses of the devices are to be set permanently, proceed as follows:

↳ Have the network administrator specify the data for IP address, net mask and gateway address of the BCL 348*i*.

↳ Set these values on the BCL 348*i*:

Via webConfig tool

↳ In the main menu, select Configuration, submenu Communication -> Ethernet interface.



Notice!

If the setting is performed via the webConfig tool, the BCL 348*i* must be **restarted**. Only after this restart is the set IP address accepted and does it become active.



Notice!

The BCL 348*i* responds to ping commands. A simple test to determine whether the address assignment was successful is to enter the previously configured IP address in a ping command (e.g. "ping 192.168.60.101" in a command line window under Windows).

10.4.8 Ethernet host communication

Chapter 10.4.3 is only of interest if an additional IP address independent of the device name is to be established for an additional communication channel, e.g. TCP/ IP. The Ethernet host communication enables the configuration of connections to an external host system. Both UDP as well as TCP/IP (in either client or server mode) can be used. The connection-free UDP protocol is used primarily to transfer process data to the host (monitor operation). The connection-oriented TCP/IP protocol can also be used to transfer commands from the host to the device. With this connection, the data is backed up by the TCP/IP protocol itself. If you would like to use the TCP/IP protocol, you must also define whether the BCL 348*i* is to operate as a TCP client or as a TCP server.

Both protocols can be activated simultaneously and used in parallel.

↳ *Contact your network administrator to determine which communication protocol is used.*

10.4.9 TCP/IP

↳ *Activate the TCP/IP protocol*

↳ *Set the TCP/IP mode of the BCL 348*i**

In **TCP client mode**, the BCL 348*i* actively establishes the connection to the primary host system (PC / PLC as server). The BCL 348*i* requires from the user the IP address of the server (host system) and the port number on which the server (host system) accepts a connection. In this case, the BCL 348*i* determines when and with whom a connection is established!

↳ *With a BCL 348*i* as TCP client, also set the following values:*

- IP address of the TCP server (normally the PLC/host computer)
- Port number of the TCP server
- Timeout for the wait time for an answer from the server
- Repetition time for renewed communication attempt following a timeout

In **TCP server mode**, the primary host system (PC / PLC) actively establishes the connection and the connected BCL 348*i* waits for the connection to be setup. The TCP/IP stack requires information from the user regarding the local port of the BCL 348*i* (port number) on which the connection requests of a client application (host system) are to be accepted. If there is a connection request and a connection is established by the primary host system (PC / PLC as client), the BCL 348*i* (server mode) accepts the connection. Data can then be sent and received.

↳ *With a BCL 348*i* as TCP server, also set the following values:*

- Port number for the communication of the BCL 348*i* with the TCP client

The corresponding adjustment options can be found:

Via webConfig:

Configuration -> Communication -> Host communication

10.4.10 UDP

The BCL 348*i* requires from the user the IP address and the port number of the communication partner. Correspondingly, the host system (PC / PLC) now also requires the set IP address of the BCL 348*i* and the selected port number. By assigning these parameters, a socket is formed via which the data can be sent and received.

↳ *Activate the UDP protocol*

↳ *Also set the following values:*

- IP address of the communication partner
- Port number of the communication partner

The corresponding adjustment options can be found:

Via webConfig:

Configuration -> Communication -> Host communication

All other parameters required for the reading task, such as setting the code type and number of digits, etc., are set using the engineering tool of the PLC with the aid of the various available modules (see chapter 10.5).

10.5 Commissioning via the PROFINET-IO

10.5.1 General information

The BCL 348*i* is designed as a modular field device. As is the case for PROFIBUS devices, the PROFINET-IO functionality of the device is defined via parameter sets that are combined in modules (slots) and sub-modules (sub-slots). The further addressing within subslots is then accomplished via an index. The modules are included in a XML-based GSD file, which is supplied as an integral part of the device. By using a user-specific configuration tool, such as, e.g., Simatic Manager for the programmable logic control by Siemens, the required modules are integrated into a project during commissioning and its settings and parameters are adjusted accordingly. These modules are provided by the GSD file.



Notice!

All input and output modules described in this documentation are described from the controller's perspective (IO Controller):

- **Input data arrives at the controller.**
- **Output data is sent out by the controller.**

Detailed information on how to prepare the control and the GSD file may be found in chapter "Configuration steps for a Siemens Simatic S7 control" on page 100.

For the default settings of the **BCL 348*i***, please refer to the following module descriptions.



Notice!

Please note that the set data is overwritten by the PLC!

*Some controls make available a so-called "universal module". This module must not be activated for the **BCL 348*i***!*

From the perspective of the device, a distinction is made between PROFINET-IO parameters and internal parameters. PROFINET-IO parameters are all parameters that can be changed via the PROFINET-IO and are described in the following modules. Internal parameters, on the other hand, can only be changed via a service interface and retain their value even following a PROFINET-IO configuration.

During the configuration phase, the BCL receives parameter telegrams from the IO Controller (master). Before this is evaluated and the respective parameter values are set, all PROFINET-IO parameters are reset to default values. This ensures that the parameters of modules that are not selected are set to the default values.

10.5.2 Permanently defined parameters / device parameters

On the PROFINET-IO, parameters may be stored in modules or may be defined permanently in a PROFINET-IO participant.

The permanently defined parameters are called "common" parameters or device-specific parameters, depending on the configuration tool.

These parameters must always be present. They are defined outside configuration modules and are thus connected to the base module (**DAP: Device Access Point**) that is addressed via slot 0/subslot 0

In Simatic Manager, the permanently defined parameters are set via object properties of the device. The module parameters are set via the module list of the selected device. By selecting the project properties of a module, the respective parameters may be set if required.

The following list contains the device parameters that are permanently defined in the BCL 348*i* (DAP Slot 0/Subslot 0) but are configurable. These parameters always exist and are available independent of the modules.

Parameter	Description	Addr.	Data type	Value range	Default	Unit
Profile number	Number of the activated profile. For BCL 348 <i>i</i> constant with value 0.	0	UNSIGNED8	0 ... 255	0	-
Code type 1	Released code type; no code means that all subsequent code tables are also deactivated. The valid number of digits also depends on the code type.	1.0 ... 1.5	BitArea	0: No code 1: 2/5 Interleaved 2: Code39 3: Code32 6: UPC, UPCE 7: EAN8, EAN13 8: Code128 10: EAN Addendum 11: Codabar 12: Code93 13: GS1 DataBar OMNIDIRECTIONAL 14: GS1 DataBar LIMITED 15: GS1 DataBar EXPANDED	1	-
Number-of-digits mode	Specifies how the subsequent numbers of digits are to be interpreted.	2.6	Bit	0: Enumeration 1: Range	0	-
Digits 1	Decodable number of digits; in the case of a range, this number defines the lower limit. ¹⁾	2.0 ... 2.5	UNSIGNED8	0 ... 63	10	-
Digits 2	Decodable number of digits; in the case of a range, this number defines the upper limit.	3	UNSIGNED8	0 ... 63	0	-
Digits 3	Decodable number of digits in the enumeration mode.	4	UNSIGNED8	0 ... 63	0	-
Digits 4	Decodable number of digits in the enumeration mode.	5	UNSIGNED8	0 ... 63	0	-
Digits 5	Decodable number of digits in the enumeration mode.	6	UNSIGNED8	0 ... 63	0	-
Reading reliability	Min. reading reliability to be achieved in order to output a read code.	7	UNSIGNED8	1 ... 100	4	-

Table 10.1: Device parameters

Parameter	Description	Addr.	Data type	Value range	Default	Unit
Check digit procedure	Used check digit procedure.	8.0 ... 8.6	BitArea	0: Standard check digit evaluation 1: No check digit verification 2: MOD10 Weight 3 3: MOD10 Weight 2 4: MOD10 Weight 4_9 5: MOD11 Cont 6: MOD43 7: MOD16	0	-
Check digit output	Turns the check digit output on or off.	8.7	Bit	Check digit output 0: Standard 1: Not standard	0	-
Code type 2	See code type 1.	9.0 ... 9.5	BitArea	See code type 1	0	-
Number-of-digits mode 2	Specifies how the subsequent numbers of digits are to be interpreted.	10.6	Bit	0: Enumeration 1: Range	0	-
Digits 2.1	Decodable number of digits; in the case of a range, this number defines the lower limit.	10.0 ... 10.5	UNSIGNED8	0 ... 63	0	-
Digits 2.2	Decodable number of digits; in the case of a range, this number defines the upper limit.	11	UNSIGNED8	0 ... 63	0	-
Digits 2.3	Decodable number of digits in the enumeration mode.	12	UNSIGNED8	0 ... 63	0	-
Digits 2.4	Decodable number of digits in the enumeration mode.	13	UNSIGNED8	0 ... 63	0	-
Digits 2.5	Decodable number of digits in the enumeration mode.	14	UNSIGNED8	0 ... 63	0	-
Reading reliability 2	Min. reading reliability to be achieved in order to output a read code.	15	UNSIGNED8	1 ... 100	4	-
Check digit procedure 2	Used check digit procedure.	16.0 ... 16.6	BitArea	0: Standard check digit evaluation 1: No check digit verification 2: MOD10 Weight 3 3: MOD10 Weight 2 4: MOD10 Weight 4_9 5: MOD11 Cont 6: MOD43 7: MOD16	0	-
Check digit output 2	Turns the check digit output on or off.	16.7	Bit	Check digit output 0: Standard 1: Not standard	0	-

Table 10.1: Device parameters

Parameter	Description	Addr.	Data type	Value range	Default	Unit
Code type 3	See code type 1.	17.0 ... 17.5	BitArea	See code type 1	0	-
Number-of-digits mode 3	Specifies how the subsequent numbers of digits are to be interpreted.	18.6	Bit	0: Enumeration 1: Range	0	-
Digits 3.1	Decodable number of digits; in the case of a range, this number defines the lower limit.	18.0 ... 18.5	UNSIGNED8	0 ... 63	0	-
Digits 3.2	Decodable number of digits; in the case of a range, this number defines the upper limit.	19	UNSIGNED8	0 ... 63	0	-
Digits 3.3	Decodable number of digits in the enumeration mode.	20	UNSIGNED8	0 ... 63	0	-
Digits 3.4	Decodable number of digits in the enumeration mode.	21	UNSIGNED8	0 ... 63	0	-
Digits 3.5	Decodable number of digits in the enumeration mode.	22	UNSIGNED8	0 ... 63	0	-
Reading reliability 3	Min. reading reliability to be achieved in order to output a read code.	23	UNSIGNED8	1 ... 100	4	-
Check digit procedure 3	Used check digit procedure	24.0 ... 24.6	BitArea	0: Standard check digit evaluation 1: No check digit verification 2: MOD10 Weight 3 3: MOD10 Weight 2 4: MOD10 Weight 4_9 5: MOD11 Cont 6: MOD43 7: MOD16	0	-
Check digit output 3	Turns the check digit output on or off.	24.7	Bit	Check digit output 0: Standard 1: Not standard	0	-

Table 10.1: Device parameters

Parameter	Description	Addr.	Data type	Value range	Default	Unit
Code type 4	See code type 1	25.0 ... 25.5	BitArea	See code type 1	0	-
Number-of-digits mode 4	Specifies how the subsequent numbers of digits are to be interpreted.	26.6	Bit	0: Enumeration 1: Range	0	-
Digits 4.1	Decodable number of digits; in the case of a range, this number defines the lower limit.	26.0 ... 26.5	UNSIGNED8	0 ... 63	0	-
Digits 4.2	Decodable number of digits; in the case of a range, this number defines the upper limit.	27	UNSIGNED8	0 ... 63	0	-
Digits 4.3	Decodable number of digits in the enumeration mode.	28	UNSIGNED8	0 ... 63	0	-
Digits 4.4	Decodable number of digits in the enumeration mode.	29	UNSIGNED8	0 ... 63	0	-
Digits 4.5	Decodable number of digits in the enumeration mode.	30	UNSIGNED8	0 ... 63	0	-
Reading reliability 4	Min. reading reliability to be achieved in order to output a read code.	31	UNSIGNED8	1 ... 100	4	-
Check digit procedure 4	Used check digit procedure.	32.0 ... 32.6	BitArea	0: Standard check digit evaluation 1: No check digit verification 2: MOD10 Weight 3 3: MOD10 Weight 2 4: MOD10 Weight 4_9 5: MOD11 Cont 6: MOD43 7: MOD16	0	-
Check digit output 4	Turns the check digit output on or off.	32.7	Bit	Check digit output 0: Standard 1: Not standard	0	-

Table 10.1: Device parameters

- 1) Specifying a 0 for the number of digits means that this entry is ignored for the device.

Parameter length: 33 byte

Input data

None

Output data

None

Notice on number of digits:

If 0 is specified in a field for the number of digits, the corresponding parameter is ignored by the device firmware.

Example:

For a code table entry x, the two code lengths 10 and 12 are to be enabled. For this purpose, the following number of digit entries are necessary:

Number of digits mode x = 0 (enumeration)

Number of digits x.1 = 10

Number of digits x.2 = 12

Number of digits x.3 = 0

Number of digits x.4 = 0

Number of digits x.5 = 0

10.6 Overview of the project modules

When using PROFINET-IO modules, the parameters are assembled dynamically, i.e., only the parameters that were selected by the activated modules are changed.

The BCL has parameters (device parameters) that must always be present. These parameters are defined outside of modules and are thus linked to the base module (DAP).

In the current version, a total of 88 modules are available for use. A **Device Module (DAP)**, see "Permanently defined parameters / device parameters" on page 109) is used for basic scanner configuration of the BCL 348*i* and is permanently integrated into the project. Further modules may be included into the project according to requirements and application.

The modules fall into the following categories:

- Parameter module for the configuration of the BCL 348*i*
- Status or control modules that influence the input/output data.
- Modules that may include both parameters and control or status information.

A PROFINET-IO module defines the existence and meaning of the input and output data. In addition, it defines the necessary parameters. The arrangement of the data within a module is defined.

The composition of the input/output data is defined via the module list.

The BCL 348*i* interprets the incoming output data and triggers the appropriate reactions in the BCL 348*i*. The interpreter for processing the data is adapted to the module structure during initialization.

The same applies for the input data. Using the module list and the defined module properties, the input data string is formatted and referenced to the internal data.

During cyclic operation, the input data is then passed on to the IO Controller.

During the startup or initialization phase, the BCL 348*i* sets the input data to an initial value (usually 0).



Notice!

*The modules can be grouped together in any order in the engineering tool. Note, however, that many BCL 348*i* modules contain linked data (e.g., the decoding result modules 20-41). It is important to maintain the **consistency of these data**.*

*The BCL 348*i* offers 34 different modules. Each of these modules may only be selected once; otherwise, the BCL 348*i* ignores the configuration.*

The BCL 348*i* checks its max. permissible number of modules. The control also reports an error if the input and output data across all selected modules exceed a total length of 1024 bytes. The specific limits of the individual modules of the BCL 348*i* are declared in the GSD file.

The following module overview shows the characteristics of the individual modules:

Module	Description	Module identifier	Submodule identifier	Parameter ¹⁾	Outp. data	Inp. data
Device parameters	Module independent device parameters	1	0	33	0	0
Interface PN-IO	Ethernet interface description	1	1	0	0	0
Port 1	Ethernet Port 1	1	2	0	0	0
Port 2	Ethernet Port 2	1	3	0	0	0
Decoder						
Code table extension 1	Extension of the existing code table	1001	1	8	0	0
Code table extension 2	Extension of the existing code table	1002	1	8	0	0
Code table extension 3	Extension of the existing code table	1003	1	8	0	0
Code table extension 4	Extension of the existing code table	1004	1	8	0	0
Code type properties	The module permits changing the muted zones as well as the line-gap ratios	1005	1	6	0	0
Code fragment technology	Support of code fragment technology	1007	1	4	0	0
Control						
Activation	Control bits for activation of the standard reading operation	1010	1	1	0	1
Reading gate control	Extended control of the reading gate	1011	1	6	0	0
Multilabel	Output of several bar codes per reading gate	1012	1	2	1	0
Fragmented read result	Transmission of the read results in the fragmented mode	1013	1	1	2	0
Interlinked read result	Interlinking of the individual read results within one reading gate	1014	1	1	0	0
Result Format						
Decoder state	Status display - decoding	1020	1	0	1	0
Decoding result 1	Bar code information 4 bytes max.	1021	1	0	6	0
Decoding result 2	Bar code information 8 bytes max.	1022	1	0	10	0
Decoding result 3	Bar code information 12 bytes max.	1023	1	0	14	0
Decoding result 4	Bar code information 16 bytes max.	1024	1	0	18	0
Decoding result 5	Bar code information 20 bytes max.	1025	1	0	22	0
Decoding result 6	Bar code information 24 bytes max.	1026	1	0	26	0
Decoding result 7	Bar code information 28 bytes max.	1027	1	0	30	0
Data formatting	Specification for formatting the data output	1030	1	23	0	0
Reading gate number	Number of the reading gate since system start-up	1031	1	0	2	0
Reading gate time	Time between opening and closing	1032	1	0	2	0
Code position	Relative position of the bar code label in the scanning beam	1033	1	0	2	0
Reading reliability	Calculated reading reliability for the transmitted bar code.	1034	1	0	2	0
Scans per bar code	Number of scans between the first and the last time of detecting the bar code	1035	1	0	2	0
Scans with information	Number of scans with processed information	1036	1	0	2	0
Decoding quality	Quality of the read result	1037	1	0	1	0
Code direction	Orientation of the bar code	1038	1	0	1	0
Number of digits	Number of digits in the bar code	1039	1	0	1	0
Code type	Bar code type	1040	1	0	1	0
Code position in the swivel range	Code position in the swivel range of an oscillating mirror device	1041	1	0	2	0

Table 10.2: Module overview

Module	Description	Module identifier	Submodule identifier	Parameter 1)	Outp. data	Inp. data
Data Processing						
Characteristics filter	Configuration of the characteristics filter	1050	1			
Data filtering	Configuration of the data filtering	1051	1	60	0	0
Segmentation acc. to the EAN process	Activation and configuration of the segmentation acc. to the EAN process	1052	1	27	0	0
Segmentation via fixed positions	Activation and configuration of the segmentation via fixed positions	1053	1	37	0	0
Segmentation acc. to identifier and separator	Activation and configuration of the segmentation acc. to identifier and separator	1054	1	29	0	0
String handling parameter	Definition of placeholder characters for bar code segmentation, filtering, completion and reference code processing	1055	1	3	0	0
Device-Functions						
Device status	Display of the device status as well as control bits for reset and standby	1060	1	0	1	1
Laser control	Switch-on and switch-off positions of the laser	1061	1	4	0	0
Alignment	Alignment mode	1063	1	0	1	1
Oscillating mirror	Configuration of the oscillating mirror	1064	1	6	0	0
Switching inputs/ outputs SWIO or Device-IO						
Switching input/output SWIO1	Parameter settings SWIO1	1070	1	23	0	0
Switching input/output SWIO2	Parameter settings SWIO2	1071	1	23	0	0
SWIO status and control	Handling of switching input and switching output signals	1074	1	0	2	2
Data output						
Sorting	Sorting support	1080	1	3	0	0
Reference code comparator 1	Definition of the operation mode of reference code comparator 1	1081	1	8	0	0
Reference code comparator 2	Definition of the operation mode of reference code comparator 2	1082	1	8	0	0
Reference code comparison pattern 1	Definition of the 1st comparison pattern	1083	1	31	0	0
Reference code comparison pattern 2	Definition of the 2nd comparison pattern	1084	1	31	0	0
Special Functions						
Status and control	Grouping of multiple status and control bits	1090	1	0	1	0
AutoRefIAct	Automatic reflector activation	1091	1	2	0	0
AutoControl	Automatic monitoring of the reading properties	1092	1	3	1	0

Table 10.2: Module overview

- 1) The number of parameter bytes does not include the constant module number, which is always transmitted in addition.



Notice!

For the standard case, at least module 10 (activation) and one of modules 21 ... 27 (decoding result 1 ... 7) should be integrated.

10.7 Decoder modules

10.7.1 Modules 1-4 – Code table extensions 1 to 4

PROFINET-IO module identifier

Module-ID 1001...1004

Submodule-ID 1

Description

The modules extend the code type tables of the device parameters and permit the additional definition of further 4 code types together with the respective number of digits.

Parameter

Parameter	Description	Rel. addr.	Data type	Value range	Default	Unit
Code type	Released code type; no code means that all subsequent code tables are also deactivated. The valid number of digits also depends on the code type.	0.0 ... 0.5	BitArea	0: 0: No code 1: 2/5 Interleaved 2: Code39 3: Code32 6: UPC, UPCE 7: EAN8, EAN13 8: Code128 10: EAN Addendum 11: Codabar 12: Code93 13: GS1 DataBar OMNIDIRECTIONAL 14: GS1 DataBar LIMITED 15: GS1 DataBar EXPANDED	0	-
Number-of-digits mode	Interpretation of the number of digits	1.6	Bit	0: Enumeration 1: Range	0	-
Digits 1 ¹⁾	Decodable number of digits; in the case of a range, this number defines the lower limit.	1.0 ... 1.5	UNSIGNED8	0 ... 63	0	-
Digits 2	Decodable number of digits; in the case of a range, this number defines the upper limit.	2	UNSIGNED8	0 ... 63	0	-
Digits 3	Decodable number of digits in the enumeration mode.	3	UNSIGNED8	0 ... 63	0	-
Digits 4	Decodable number of digits in the enumeration mode.	4	UNSIGNED8	0 ... 63	0	-
Digits 5	Decodable number of digits in the enumeration mode.	5	UNSIGNED8	0 ... 63	0	-

Table 10.3: Parameters for modules 1-4

Parameter	Description	Rel. addr.	Data type	Value range	Default	Unit
Reading reliability	Min. reading reliability to be achieved in order to output a read code.	6	UNSIGNED8	1 ... 100	4	-
Check digit procedure	Used check digit procedure.	7.0 ... 7.6	BitArea	0: Standard check digit evaluation 1: No check digit verification 2: MOD10 Weight 3 3: MOD10 Weight 2 4: MOD10 Weight 4_9 5: MOD11 Cont 6: MOD43 7: MOD16	0	-
Check digit output	Turns the check digit output on or off. >Standard means that the check digit is transmitted according to the applicable standard for the selected code type If no check digit transmission is intended for the selected code type, then " Standard " means that the check digit is not transmitted and " Not Standard " means that the check digit is transmitted anyway.	7.7	Bit	Check digit output 0: Standard 1: Not standard	0	-

Table 10.3: Parameters for modules 1-4

- 1) Cf. in Permanently defined parameters / device parameters section 10.5.2 the notice on number of digits.

Parameter length

8 bytes

Input data

None

Output data

None

10.7.2 Module 5 – Code type features (symbology)

PROFINET-IO module identifier

Module-ID 1005

Submodule-ID 1

Description

The module defines extended features for various code types.

Parameter

Parameter	Description	Addr.	Data type	Value range	Default	Unit
Maximum width deviation	Max. permitted width deviation of a character in percent of the directly adjacent character.	0	UNSIGNED8	0 ... 100	15	%
Code 39 max. element ratio	Permissible ratio between maximum and minimum element of Code 39.	1	UNSIGNED8	0 ... 255	8	-
Code 39 character gap	Permissible ratio for the gap between two characters for Code 39.	2	UNSIGNED8	0 ... 255	3	-
Codabar max. element ratio	Permissible ratio between maximum and minimum element of the Codabar code.	3	UNSIGNED8	0 ... 255	8	-
Codabar character gap	Permissible ratio for the gap between two characters for the Codabar code.	4	UNSIGNED8	0 ... 255	3	-
Codabar Monarch Mode	The decoding of a Monarch bar code as Codabar bar code can be switched on or off.	5.0	Bit	0: Off 1: On	0	-
Codabar start/stop character	Switches the transmission of a start and stop character for the Codabar code on and off.	5.1	Bit	0: Off 1: On	0	-
UPC-E extension	Switches the extension of a UPC-E code to a UPC-A result on and off.	5.4	Bit	0: Off 1: On	0	-
Code 128: activate EAN header	Switches the output of the EAN header on and off.	5.5	Bit	0: Off 1: On	1	-
Code 39 conversion	Defines the conversion method used for Code 39.	5.6 ... 5.7	BitArea	0: Standard (usual conversion method) 1: Standard ASCII (combination of standard method and ASCII method) 2: ASCII (This conversion method uses the entire ASCII character set)	0	-

Table 10.4: Parameters for module 5

Parameter length

6 byte

Input data

None

Output data

None

10.7.3 Module 7 – Code fragment technology

PROFINET-IO module identifier

Module-ID 1007
 Submodule-ID 1

Description

Module for supporting the code fragment technology.

Parameter

Parameter	Description	Addr.	Data type	Value range	Default	Unit
Maximum width ratio	The maximum width ratio is used to determine the light zones. The light zones identify the beginning or end of patterns.	0	UNSIGNED8	0 ... 255	13	-
Minimum number of elements	A pattern must have at least this minimum number of duo-elements, i.e. no patterns which have fewer duo-elements.	1 ... 2	UNSIGNED16	2 ... 400	6	-
Code fragment mode	This parameter can be used to switch CRT mode on and off.	3.0	Bit	0: Switched off 1: Switched on	1	-
Processing end at end of label	If this parameter is set, a decoded bar code is only completely decoded after the scanning beam has exited the entire bar code.	3.2	Bit	0: Switched off 1: Switched on	0	-

Table 10.5: Parameters for module 7

Parameter length

4 byte

Input data

None

Output data

None



Notice!

Processing end at end of label:

If this parameter is set, a decoded bar code is only completely decoded after the scanning beam has exited the entire bar code. This mode is useful if the quality of the bar code is to be assessed, since more scans are now available for the quality evaluation of the bar code.

This parameter should be set if the AutoControl function is activated (see chapter 10.16.3 "Module 92 – AutoControl"). If the parameter is not set, the bar code is immediately detected and processed further as soon as all necessary bar code elements are available.

10.8 Control modules

10.8.1 Module 10 – Activations

PROFINET-IO module identifier

Module-ID 1010

Submodule-ID 1

Description

The module defines the control signals for the reading operation of the bar code reader. It is possible to select between standard reading operation and handshake operation.

In handshake operation, the controller must acknowledge the data reception via the ACK bit before the new data is written into the input area.

After acknowledging the last decoding result, the input data is reset (filled with zeros).

Parameter

Parameter	Description	Addr.	Data type	Value range	Default	Unit
Mode	The parameter defines the mode in which the activation module is operated.	0	UNSIGNED8	0: Without ACK ¹⁾ 1: With ACK ²⁾	0	-

Table 10.6: Parameters for module 10

- 1) corresponds to BCL34 module 18
- 2) corresponds to BCL34 module 19

Parameter length

1 byte

Input data

None

Output data

Output data	Description	Addr.	Data type	Value range	Init value	Unit
Reading gate	Signal for activating the reading gate	0.0	Bit	1 -> 0: Reading gate off 0 -> 1: Reading gate active	0	-
	Free	0.1	Bit		0	-
	Free	0.2	Bit		0	-
	Free	0.3	Bit		0	-
Data acknowledgement	This control bit signals that the transmitted data have been processed by the master. Only relevant in handshake mode (with ACK).	0.4	Bit	0 -> 1: Data has been processed by the master 1 -> 0: Data has been processed by the master	0	-
Data reset	Deletes decoding results that may have been stored and resets the input data of all modules.	0.5	Bit	0 -> 1: Data reset	0	-
	Free	0.6	Bit			
	Free	0.7	Bit			

Table 10.7: Output data for module 10

Output data length

1 byte consistent

**Notice!**

If several bar codes are decoded in sequence without the acknowledge mode having been activated, the input data of the result modules are overwritten with the respective most recently read decoding result.

If a data loss in the control is to be avoided in such a case, mode 1 (with Ack) should be activated.

*If multiple decoding results occur within one reading gate, it is possible - dependent on the cycle time - that only the last decoding result is visible on the bus. In this case, the acknowledge mode **MUST** be used. There is otherwise a risk of data loss.*

Multiple, individual decoding results may occur within one reading gate if the Module 12 – Multi-label (see chapter 10.8.3) or one of the identifier modules (see chapter 10.11 "Identifier" beginning on page 142) is used.

Data reset behavior:

If the data reset control bit is activated, the following actions are carried out:

1. Deletion of decoding results that may still be stored.
2. Reset of module 13 - fragmented read result (see chapter 10.8.4), i.e., even a partially transmitted read result is deleted.
3. Deletion of the input data areas of all modules. Exception: The input data of module 60 - device status (see chapter 10.12.1) is not deleted. For the status byte of decoding result modules 20 ... 27 (see chapter 10.9.2), the two toggle bytes and the reading gate status remain unchanged.

10.8.2 Module 11 – Reading gate control

PROFINET-IO module identifier

Module-ID 1011

Submodule-ID

Description

With the module, the reading gate control of the bar code reader can be adapted to the application. With different parameters from the bar code reader, a time-controlled reading gate may be created. In addition, it defines the internal criteria for the reading gate end and the completeness inspection.

Parameter

Parameter	Description	Addr.	Data type	Value range	Default	Unit
Automatic reading gate repeat	The parameter defines the automatic repeat of reading gates.	0	Byte	0: No 1: Yes	0	-
Reading gate end mode/ completeness mode	This parameter can be used to configure the completeness inspection.	1	Byte	0: Independent of decoding , i.e., the reading gate is not terminated prematurely. 1: Dependent on decoding , i.e, the reading gate is terminated if the configured number of bar codes to be decoded has been reached. ¹⁾ 2: DigitRef table-dependent , i.e., the reading gate is terminated if each bar code stored in the code type table has been decoded. ²⁾ 3: Ident list dependent , i.e., the reading gate is terminated if each identifier stored in a list could be segmented via a respective bar code segmentation. ³⁾ 4: Reference code comparison , i.e., the reading gate is terminated if a positive reference code comparison has taken place. ⁴⁾	1	-

Table 10.8: Parameters for module 11

Parameter	Description	Addr.	Data type	Value range	Default	Unit
Restart delay	The parameter specifies a time after which a reading gate is restarted. The BCL 348 <i>i</i> generates its own periodic reading gate. The configured time is active only if the automatic reading gate repeat is switched on.	2	UNSIGNED16	0 ... 65535	0	ms
Max. reading gate time when scanning	The parameter switches off the reading gate after the set time has elapsed, thus limiting the reading gate to the set period.	4	UNSIGNED16	1 ... 65535 0: Reading gate deactivation is switched off.	0	ms

Table 10.8: Parameters for module 11

- 1) See "Module 12 – Multi-label" on page 124.
- 2) Corresponds to the settings carried out via the device module (chapter 10.5.2) or Modules 1-4 – Code table extensions 1 to 4.
- 3) See "Identifier" on page 142, modules 52-54 "Identifier filter string"
- 4) See Module 83 – Reference code comparison pattern 1 and Module 84 – Reference code comparison pattern 2

Parameter length

6 byte

Input data

None

Output data

None

10.8.3 Module 12 – Multi-label

PROFINET-IO module identifier

Module-ID 1012
 Submodule-ID 1

Description

The module permits the definition of multiple bar codes with a different number of digits and/or code types in the reading gate and provides the necessary input data.

Parameter

Parameter	Description	Addr.	Data type	Value range	Default	Unit
Minimum number of bar codes	Minimum number of different bar codes scanned for per reading gate.	0	UNSIGNED8	0 ... 64	1	-
Maximum number of bar codes	Maximum number of different bar codes scanned for per reading gate. Only if this number of bar codes has been reached, the reading gate is terminated prematurely. ¹⁾	1	UNSIGNED8	0 ... 64	1	-

Table 10.9: Parameters for module 12

- 1) Compare with "Module 11 – Reading gate control" on page 122, parameter "reading gate termination mode"

Parameter length

2 bytes

Input data

Input data	Description	Addr.	Data type	Value range	Init value	Unit
Number of decoding results	Number of decoding results which have not been fetched.	0	UNSIGNED8	0 ... 255	0	-

Table 10.10: Input data for module 12

Input data length

1 byte

Output data

None

This module is used to set the maximum and minimum number of bar codes which are to be decoded within a reading gate. If parameter "minimum number of bar codes" = 0, it is not taken into account at the decoder controller. If it is not equal to 0, this means that the bar code reader expects a number of labels within the set range.

If the number of decoded bar codes is within the set limits, no additional "No Reads" are output.

Notice!



When using this module, the ACK mode should be activated (see Module 10 – Activations, "Mode" parameter). Otherwise there is a risk of losing decoding results if the control is not fast enough.

10.8.4 Module 13 – Fragmented read result

PROFINET-IO module identifier

Module-ID 1013
 Submodule-ID 1

Description

The module defines the transfer of fragmented read results. To occupy few i/o-data, the read results may be split into several fragments with this module. The fragments can then be transmitted one after another with a handshake.

Parameter

Parameter	Description	Addr.	Data type	Value range	Default	Unit
Fragment length	The parameter defines the maximum length of the bar code information per fragment.	0	UNSIGNED8	1 ... 28	0	-

Table 10.11: Parameters for module 13

Parameter length

1 byte

Input data

Input data	Description	Addr.	Data type	Value range	Init value	Unit
Fragment number	Current fragment number	0.0 ... 0.3	Bitarea	0 ... 15	0	-
Remaining fragments	Number of fragments which still have to be read for a complete result.	0.4 ... 0.7	Bitarea	0 ... 15	0	-
Fragment size	Fragment length, always corresponds to the configured fragment length, except for the last fragment.	1	UNSIGNED8	0 ... 28	0	-

Table 10.12: Input data for module 13

Input data length

2 byte consistent

Output data

None

10.8.5 Module 14 – Interlinked read result

PROFINET-IO module identifier

Module-ID 1014

Submodule-ID 1

Description

This module is used to switch to a mode in which all decoding results within one reading gate are combined into a single read result.

Parameter

Parameter	Description	Addr.	Data type	Value range	Default	Unit
Delimiter	This parameter is used to define a delimiter that is inserted between two individual decoding results.	0	UNSIGNED8	1 ... 255 0: No delimiter is used.	' '	-

Table 10.13: Parameters for module 13

Parameter length

1 byte

Input data

None

Output data

None



Notice!

An interlinked read result also requires Module 12 – Multi-label. In this mode, the additional information transmitted in modules 31ff relates to the last decoding result in the chain.

10.9 Result Format

In the following various modules for the output of decoding results are listed. They have the same structure but different output lengths. The PROFINET-IO module concept does not cater for modules of variable data length.



Notice!

Modules 20 ... 27 are, thus, to be regarded as alternatives and should not be used in parallel.
 Modules 30 ... 41, on the other hand, can be combined freely with the decoding result modules.

10.9.1 Module 20 – Decoder state

PROFINET-IO module identifier

Module-ID 1020
 Submodule-ID 1

Description

The module indicates the state of the decoding and of the automatic decoder configuration.

Parameter

None

Input data

Input data	Description	Addr.	Data type	Value range	Init value	Unit
Reading gate state	The signal indicates the current state of the reading gate ¹⁾ .	0.0	Bit	0: Off 1: On	0	-
New result	The signal indicates whether a new decoding has occurred.	0.1	Bit	0: No 1: Yes	0	-
Result state	The signal indicates whether the bar code has been read successfully.	0.2	Bit	0: Successful reading 1: NOREAD	0	-
Further results in the buffer	The signal indicates whether further results are in the buffer.	0.3	Bit	0: No 1: Yes	0	-
Buffer overflow	The signal indicates that result buffers are occupied and the decoder rejects data.	0.4	Bit	0: No 1: Yes	0	-
New decoding	Toggle bit indicates whether decoding has occurred.	0.5	Bit	0->1: New result 1->0: New result	0	-
Result state	Toggle bit indicates that the bar code has not been read.	0.6	Bit	0->1: NOREAD 1->0: NOREAD	0	-
Waiting for acknowledgement	This signal represents the internal state of the control.	0.7	Bit	0: Base state 1: Control waiting for acknowledgement from the IO Controller	0	-

Table 10.14: Input data for module 20

- 1) **Attention:** This does not necessarily correspond to the state at the time the bar code is scanned.

Input data length

1 byte

Output data

None

Remarks

The following bits are constantly updated, i.e. they are updated immediately after the respective event occurs:

Reading gate state

- Further results in the buffer
- Buffer overflow
- Waiting for acknowledgement

All other flags refer to the currently output decoding result.

If the input data is reset to the init. value (cf. "Module 30 – Data formatting" on page 131), the following bits are reset:

- New result
- Result state

All others remain unchanged.

Data reset behavior:

Upon data reset (see Module 10 – Activations), the input data is deleted, except for the reading gate status and the two toggle bits.

10.9.2 Modules 21-27 – Decoding result

PROFINET-IO module identifier

Module-ID 1021...1027

Submodule-ID 1

Description

The module defines the transfer of the actually decoded read results. The data is transmitted consistently over the entire range.

Parameter

None

Input data

Module No.	Input data	Description	Addr.	Data type	Value range	Init value	Unit
21 ... 27	Reading gate state	The signal indicates the current state of the reading gate. ¹⁾	0.0	Bit	0: Off 1: On	0	-
21 ... 27	New result	Signal indicates whether a new decoding result is present.	0.1	Bit	0: No 1: Yes	0	-
21 ... 27	Result state	Signal indicates whether the bar code has been read successfully.	0.2	Bit	0: Successful reading 1: NOREAD	0	-
21 ... 27	Further results in the buffer	Signal indicates whether further results are in the buffer.	0.3	Bit	0: No 1: Yes	0	-
21 ... 27	Buffer overflow	Signal indicates that result buffers are occupied and the decoder rejects data.	0.4	Bit	0: No 1: Yes	0	-
21 ... 27	New result	Toggle bit, indicates that a new decoding result is present.	0.5	Bit	0->1: New result 1->0: New result	0	-
21 ... 27	Result state	Toggle bit indicates that the bar code has not been read.	0.6	Bit	0->1: NOREAD 1->0: NOREAD	0	-
21 ... 27	Waiting for acknowledgement	This signal represents the internal state of the control.	0.7	Bit	0: Base state 1: Control waiting for acknowledgement from the IO Controller	0	-
21 ... 27	Bar code data length	Data length of the actual bar code information. ²⁾	1	UNSIGNED8	0-48	0	-
21	Data	Bar code information with a length of consistently 4 bytes.	2..	4x UNSIGNED8	0-FFh	0	-
22	Data	Bar code information with a length of consistently 8 bytes.	2..	8x UNSIGNED8	0-FFh	0	-
23	Data	Bar code information with a length of consistently 12 bytes.	2..	12x UNSIGNED8	0-FFh	0	-
24	Data	Bar code information with a length of consistently 16 bytes.	2..	16x UNSIGNED8	0-FFh	0	-
25	Data	Bar code information with a length of consistently 20 bytes.	2..	20x UNSIGNED8	0-FFh	0	-
26	Data	Bar code information with a length of consistently 24 bytes.	2..	24x UNSIGNED8	0-FFh	0	-
27	Data	Bar code information with a length of consistently 28 bytes.	2..	28x UNSIGNED8	0-FFh	0	-

Table 10.15: Input data for modules 21 ... 27

1) Attention: This does not necessarily correspond to the state at the time the bar code is scanned

- 2) If the bar code information (bar code and, possibly, other items such as the check sum) fits in the selected module width, this value reflects the length of the transmitted data. A value larger than the module width indicates a loss of information caused by a module width which has been selected too small.

Input data

2 bytes consistently + 4..28 bytes of bar code information depending on the module

Output data

None

Remarks

The remarks for module 20 – decoder state, apply in an analogous manner.

In addition, all bytes beginning with address 1 are reset to the init. value.

**Notice!**

Shortening decoding results that are too long: If the bar code information (bar code possibly including supplementary information such as the check sum) does not fit in the selected module width, the decoding results are shortened. This shortening is either from the left or the right depending on the setting in Module 30 – Data formatting.

Shortening is indicated by the passed bar code data length.

10.9.3 Module 30 – Data formatting

PROFINET-IO module identifier

Module-ID 1030
 Submodule-ID 1

Description

The module defines the output string for the case that the BCL 348*i* could not read a bar code. In addition, the initialization of the data fields and the definition of unused data ranges may be set.

Parameter

Parameter	Description	Addr.	Data type	Value range	Default	Unit
Text in the case of misreading	The parameter defines the output characters if no bar code could be read.	0	STRING 20 characters null terminated	1 ... 20 bytes of ASCII characters	63 ("?")	-
Decoding result at reading gate start	The parameter defines the state of the data at the start of the reading gate.	20.5	Bit	0: Input data remain on the old value 1: Input data is reset to the init value	0	-
Data alignment	The parameter defines the alignment of the data in the result field ¹⁾	21.0	Bit	0: Left-justified 1: Right-justified	0	-
Fill mode	The parameter defines the fill mode for the unoccupied data ranges	21.4 ... 21.7	Bitarea	0: No fill up 3: Fill up to the transmission length	3	-
Fill character	The parameter defines the character which is used for filling up the data ranges.	22	UNSIGNED8	0 ... FFh	0	-

Table 10.16: Parameters for module 30

- 1) And thus also controls possible shortening of a decoding result that is too large.

Parameter length

23 byte

Input data

None

Output data

None

Comment

The "decoding result at reading gate start" parameter is only taken into account if the "Without ACK" mode is set (cf. "Module 10 – Activations" on page 120).



Notice!

The text for erroneous readings does not permit the use of ASCII characters that cannot be displayed (<0x20h).

10.9.4 Module 31 – Reading gate number

PROFINET-IO module identifier

Module-ID 1031

Submodule-ID 1

Description

The module defines input data for the communication of the number of reading gates since system start.

Parameter

None

Input data

Input data	Description	Addr.	Data type	Value range	Init value	Unit
Reading gate number	The BCL 348 <i>i</i> transmits the current reading gate number. The reading gate number is initialized with the system start and is then incremented continuously. At 65535, an overflow occurs and the counter starts afresh from 0.	0 ... 1	UNSIGNED16	0 ... 65535	0	-

Table 10.17: Input data for module 31

Input data length

2 byte consistent

Output data

None

10.9.5 Module 32 – Reading gate time

PROFINET-IO module identifier

Module-ID 1032
 Submodule-ID 1

Description

This module returns the time between opening and closing of the last reading gate.

Parameter

None

Input data

Input data	Description	Addr.	Data type	Value range	Init value	Unit
Opening duration of the reading gate	Opening duration of the last reading gate in ms.	0 ... 1	UNSIGNED16	0 ... 65535 If the range is exceeded, the value remains at 65535	0	ms

Table 10.18: Input data for module 32

Input data length

2 byte consistent

Output data

None

10.9.6 Module 33 – Code position

PROFINET-IO module identifier

Module-ID 1033
 Submodule-ID 1

Description

The module defines input data for the communication of the relative bar code position in the laser beam.

Parameter

None

Input data

Input data	Description	Addr.	Data type	Value range	Init value	Unit
Code position	Relative position of the bar code in the scanner beam. The position is normalized to the zero position (middle position). Specified in 1/10 degrees.	0 ... 1	SIGNED16	±450	0	1/10 degree

Table 10.19: Input data for module 33

Input data length

2 byte consistent

Output data

None

10.9.7 Module 34 – Reading reliability (equal scans)

PROFINET-IO module identifier

Module-ID 1034

Submodule-ID 1

Description

The module defines the input data for the communication of the calculated reading reliability. The value refers to the currently output bar code.

Parameter

None

Input data

Input data	Description	Addr.	Data type	Value range	Init value	Unit
Reading reliability (Equal scans)	Calculated reading reliability for the transmitted bar code.	0 ... 1	UNSIGNED16	0 ... 65535	0	-

Table 10.20: Input data for module 34

Input data length

2 byte consistent

Output data

None

10.9.8 Module 35 – Bar code length

PROFINET-IO module identifier

Module-ID 1035

Submodule-ID 1

Description

The module defines the input data for the communication of the length of the currently output bar code.

Parameter

None

Input data

Input data	Description	Addr.	Data type	Value range	Init value	Unit
Bar code length	Length/duration of the currently output bar code, beginning with the code position specified in module 35 in 1/10 degrees.	0 ... 1	UNSIGNED16	1 ... 900	1	1/10 degree

Table 10.21: Input data for module 35

Input data length

2 byte consistent

Output data

None

10.9.9 Module 36 – Scans with information

PROFINET-IO module identifier

Module-ID 1036
 Submodule-ID 1

Description

The module defines input data for the communication of the calculated number of scans which provided information contributing to the result of the bar code.

Parameter

None

Input data

Input data	Description	Addr.	Data type	Value range	Init value	Unit
Scans with information per bar code	See above.	0 ... 1	UNSIGNED16	0 ... 65535	0	-

Table 10.22: Input data for module 36

Input data length

2 byte consistent

Output data

None

10.9.10 Module 37 – Decoding quality

PROFINET-IO module identifier

Module-ID 1037
 Submodule-ID 1

Description

The module defines input data for the communication of the calculated decoding quality of the currently transmitted bar code.

Parameter

None

Input data

Input data	Description	Addr.	Data type	Value range	Init value	Unit
Decoding quality	Decoding quality of the transmitted bar code.	0	UNSIGNED8	0 ... 100	0	1%

Table 10.23: Input data for module 37

Input data length

1 byte consistent

Output data

None

10.9.11 Module 38 – Code direction

PROFINET-IO module identifier

Module-ID 1038

Submodule-ID 1

Description

The module defines input data for the communication of the detected code direction of the currently transmitted bar code.

Parameter

None

Input data

Input data	Description	Addr.	Data type	Value range	Init value	Unit
Code direction	Code direction of the transmitted bar code	0	UNSIGNED8	0: Normal 1: Inverted 2: Unknown	0	-

Table 10.24: Input data for module 38

Input data length

1 byte

Output data

None

Comment:

A decoding result of type "No Read" has as code direction the value 2 = unknown!

10.9.12 Module 39 – Number of digits

PROFINET-IO module identifier

Module-ID 1039

Submodule-ID 1

Description

The module defines input data for the communication of the number of digits of the currently transmitted bar code.

Parameter

None

Input data

Input data	Description	Addr.	Data type	Value range	Init value	Unit
Number of digits	Number of digits of the transmitted bar code	0	UNSIGNED8	0 ... 48	0	-

Table 10.25: Input data for module 39

Input data length

1 byte

Output data

None

10.9.13 Module 40 – Code type (symbology)

PROFINET-IO module identifier

Module-ID 1040
 Submodule-ID 1

Description

The module defines the input data for the communication of the code type of the currently transmitted bar code.

Parameter

None

Input data

Input data	Description	Addr.	Data type	Value range	Init value	Unit
Code type (symbology)	Code type of the transmitted bar code	0	UNSIGNED8	0: No code 1: 2/5 Interleaved 2: Code39 6: UPC, UPCE 7: EAN8, EAN13 8: Code128, EAN128 10: EAN Addendum 11: Codabar 12: Code93 13: GS1 DataBar Omnidirectional 14: GS1 DataBar Limited 15: GS1 DataBar Expanded	0	-

Table 10.26: Input data for module 40

Input data length

1 byte

Output data

None

10.9.14 Module 41 – Code position in the swivel range

PROFINET-IO module identifier

Module-ID 1041

Submodule-ID 1

Description

The module defines input data for the communication of the relative bar code position in the swivel range of an oscillating mirror device.

Parameter

None

Input data

Input data	Description	Addr.	Data type	Value range	Init value	Unit
Position in the swivel range	Relative position of the bar code in the swivel range. The position is normalized to the zero position (middle position). Specified in 1/10 degrees.	0 ... 1	SIGNED16	-200 ... +200	0	1/10°

Table 10.27: Input data for module 41

Input data length

2 bytes

Output data

None

10.10 Data Processing

10.10.1 Module 50 – Characteristics filter

PROFINET-IO module identifier

Module-ID 1050

Submodule-ID 1

Description

Configuration of the characteristics filter.

This filter can be used to set how bar codes with identical content are handled and what criteria are to be taken into account in determining the likeness.

Parameter

Parameter	Description	Addr.	Data type	Value range	Default	Unit
Handling of identical bar code information	Determines how bar codes with the same content are to be managed.	0	UNSIGNED8	0: All bar codes are stored and output. 1: Only non-identical bar code contents are output.	1	-
Comparison parameter - code type	If this criterion has been activated, the bar code type is used to determine whether the bar codes are identical.	1.0	Bit	0: deactivated 1: activated	1	-
Comparison parameter - bar code content	If this criterion has been activated, the bar code content is used to determine whether the bar codes are identical.	1.1	Bit	0: deactivated 1: activated	1	-
Comparison parameter - bar code direction	If this criterion has been activated, the bar code direction is used to determine whether the bar codes are identical.	1.2	Bit	0: deactivated 1: activated	1	-
Comparison parameter - scan position	If this parameter is not equal to 0, the bar code position in the scanning beam is used to determine whether identical bar codes have already been decoded. In this case, a +/- bandwidth in degrees must be specified, within which the same bar code is permitted to be in the scanning beam.	2 ... 3	UNSIGNED16	0 ... 450	0	1/10 degree

Table 10.28: Parameters for module 50

Parameter	Description	Addr.	Data type	Value range	Default	Unit
Comparison parameter - oscillating mirror position	If this parameter is not equal to 0, the bar code position in the swivel range of the oscillating mirror is used to determine whether identical bar codes have already been decoded. A +/- bandwidth in degrees must then be specified, within which the same bar code is permitted to be in the oscillating mirror swivel range.	4 ... 5	UNSIGNED16	0 ... 200	0	1/10 degree
Comparison parameter - scanning time info	If this parameter is not equal to 0, the decoding time (time at which the bar code was decoded) is used to determine whether identical bar codes have already been detected. Here, a difference time specified in milliseconds ensures that identical bar codes may only occur within this time.	6 ... 7	UNSIGNED16	0 ... 65535	0	ms

Table 10.28: Parameters for module 50

Parameter length

8 byte

Input data

None

Output data

None

All comparison criteria are AND linked; this means all active comparisons must be fulfilled before the just-decoded bar code can be identified as already decoded and then deleted.

10.10.2 Module 51 – Data filtering

PROFINET-IO module identifier

Module-ID 1051
 Submodule-ID 1

Description

Configuration of the data filter.

Parameter

Parameter	Description	Add r.	Data type	Value range	Default	Unit
Bar code filter string 1	Filter expression 1	0	STRING 30 characters null terminated	1 ... 30 bytes of ASCII characters	\00	-
Bar code filter string 2	Filter expression 2	30	STRING 30 characters null terminated	1 ... 30 bytes of ASCII characters	\00	-

Table 10.29: Parameters for module 51

Parameter length

60 byte

Input data

None

Output data

None

Filter string

The filter string is used to define passthrough filters for bar codes.

An arbitrary number of '?' are permitted as placeholders for an arbitrary character at exactly this position. Also permitted are '*' as placeholders for a character sequence of arbitrary length, and an 'x' if the character at the respective position is to be deleted.



Notice!

ASCII characters that cannot be displayed (<0x20h) must not be used.

10.11 Identifier

The following modules can be used to specify the segmentation process to be used when extracting identifiers from the bar code data.

When a module is configured, the associated segmentation process is activated. If none of the modules is configured, no segmentation takes place.

Therefore, the modules can only be used one at a time and not simultaneously.



Notice!

When using one of the following modules, multiple results may occur within a reading gate. If there are multiple results, acknowledge mode must be used (cf. "Module 10 – Activations" on page 120, "Mode" parameter and the additional notices); data may otherwise be lost!

10.11.1 Module 52 – Segmentation according to the EAN process

PROFINET-IO module identifier

Module-ID 1052

Submodule-ID 1

Description

The module activates the segmentation according to the EAN process. The parameters specify the identifiers to searched for and the output mode.

Parameter

Parameter	Description	Addr.	Data type	Value range	Default	Unit
Identifier list						
Identifier 1	The identifier string is used for the identifier list and the filtering according to the segmentation.	0	STRING 5 characters null terminated	1 ... 5 bytes of ASCII characters	""	-
Identifier 2	See identifier 1.	5	STRING 5 characters null terminated	1 ... 5 bytes of ASCII characters	\0	-
Identifier 3	See identifier 1.	10	STRING 5 characters null terminated	1 ... 5 bytes of ASCII characters	\0	-
Identifier 4	See identifier 1.	15	STRING 5 characters null terminated	1 ... 5 bytes of ASCII characters	\0	-
Identifier 5	See identifier 1.	20	STRING 5 characters null terminated	1 ... 5 bytes of ASCII characters	\0	-

Table 10.30: Parameters for module 52

Parameter	Description	Addr.	Data type	Value range	Default	Unit
Identifier output						
Output with identifier	If this switch is not set, the output of the identifiers is suppressed. Only the data values that belong to the identifiers are displayed in this case.	25.0	Bit	0: Output of the identifiers is suppressed. 1: Identifiers are output.	1	-
Output delimiter	This delimiter, if not equal to 0, is inserted between the identifier and the associated data value in the output.	26	UNSIGNED8	0 ... 127	0	-

Table 10.30: Parameters for module 52

Parameter length

27 byte

Input data

None

Output data

None

Identifier string n (n = 1 ... 5)

The identifier string defines both the identifier list for the segmentation and the passthrough filter for the subsequent filtering.

The string may contain wildcards. That is, an arbitrary number of '?' are permitted as placeholders for an arbitrary character at exactly that position.

Also permitted are '*' as placeholders for a character sequence of arbitrary length, and an 'x' if the character at the respective position is to be deleted. There are a total of 5 identifier strings.

An identifier with less than 5 characters must be null terminated. However, if the identifier string consists of exactly 5 characters, it does not have to be null terminated.



Notice!

ASCII characters that cannot be displayed (<0x20h) must not be used in the identifier strings.

10.11.2 Module 53 – Segmentation via fixed positions

PROFINET-IO module identifier

Module-ID 1053

Submodule-ID 1

Description

The module activates the segmentation via fixed positions. The parameters specify the identifiers to be searched for, the output mode, and the positions.

Parameter

Parameter	Description	Addr.	Data type	Value range	Default	Unit
Identifier list						
Identifier 1	The identifier string is used for the identifier list and the filtering according to the segmentation.	0	STRING 5 characters null terminated	1 ... 5 bytes of ASCII characters	""	-
Identifier 2	See identifier 1.	5	STRING 5 characters null terminated	1 ... 5 bytes of ASCII characters	\0	-
Identifier 3	See identifier 1.	10	STRING 5 characters null terminated	1 ... 5 bytes of ASCII characters	\0	-
Identifier 4	See identifier 1.	15	STRING 5 characters null terminated	1 ... 5 bytes of ASCII characters	\0	-
Identifier 5	See identifier 1.	20	STRING 5 characters null terminated	1 ... 5 bytes of ASCII characters	\0	-
Identifier output						
Output with identifier	If this switch is not set, the output of the identifiers is suppressed. Only the data values that belong to the identifiers are displayed in this case.	25.0	Bit	0: Output of the identifiers is suppressed. 1: Identifiers are output.	1	-
Output delimiter	This delimiter, if not equal to 0, is inserted between the identifier and the associated data value in the output.	26	UNSIGNED8	0 ... 127	0	-
Fixed positions						
Start position of the 1st identifier	Specifies the position of the first character of the first identifier in the data string of the bar code. The first character in the bar code has position 1. If the parameter is = 0, it is deactivated.	27	UNSIGNED8	0 ... 127	0	-
Start position of the 1st data value	Specifies the position of the first character of the first data value in the data string of the bar code. The first character in the bar code has position 1. If the parameter is = 0, it is deactivated.	28	UNSIGNED8	0 ... 127	0	-
Start position of the 2nd identifier	Specifies the position of the first character of the second identifier in the data string of the bar code. The first character in the bar code has position 1. If the parameter is = 0, it is deactivated.	29	UNSIGNED8	0 ... 127	0	-
Start position of the 2nd data value	Specifies the position of the first character of the second data value in the data string of the bar code. The first character in the bar code has position 1. If the parameter is = 0, it is deactivated.	30	UNSIGNED8	0 ... 127	0	-
Start position of the 3rd identifier	Specifies the position of the first character of the third identifier in the data string of the bar code. The first character in the bar code has position 1. If the parameter is = 0, it is deactivated.	31	UNSIGNED8	0 ... 127	0	-

Table 10.31: Parameters for module 53

Parameter	Description	Addr.	Data type	Value range	Default	Unit
Start position of the 3rd data value	Specifies the position of the first character of the third data value in the data string of the bar code. The first character in the bar code has position 1. If the parameter is = 0, it is deactivated.	32	UNSIGNED8	0 ... 127	0	-
Start position of the 4th identifier	Specifies the position of the first character of the fourth identifier in the data string of the bar code. The first character in the bar code has position 1. If the parameter is = 0, it is deactivated.	33	UNSIGNED8	0 ... 127	0	-
Start position of the 4th data value	Specifies the position of the first character of the fourth data value in the data string of the bar code. The first character in the bar code has position 1. If the parameter is = 0, it is deactivated.	34	UNSIGNED8	0 ... 127	0	-
Start position of the 5th identifier	Specifies the position of the first character of the fifth identifier in the data string of the bar code. The first character in the bar code has position 1. If the parameter is = 0, it is deactivated.	35	UNSIGNED8	0 ... 127	0	-
Start position of the 5th data value	Specifies the position of the first character of the fifth data value in the data string of the bar code. The first character in the bar code has position 1. If the parameter is = 0, it is deactivated.	36	UNSIGNED8	0 ... 127	0	-

Table 10.31: Parameters for module 53

Parameter length

37 byte

Input data

None

Output data

None

Identifier string n (n = 1 ... 5)

The identifier string defines both the identifier list for the segmentation and the passthrough filter for the subsequent filtering.

The string may contain wildcards. That is, an arbitrary number of '?' are permitted as placeholders for an arbitrary character at exactly that position.

Also permitted are '*' as placeholders for a character sequence of arbitrary length, and an 'x' if the character at the respective position is to be deleted. There are a total of 5 identifier strings.

An identifier with less than 5 characters must be null terminated. However, if the identifier string consists of exactly 5 characters, it does not have to be null terminated.



Notice!

ASCII characters that cannot be displayed (<0x20h) must not be used in the identifier strings.

10.11.3 Module 54 – Segmentation according to identifier and separator

PROFINET-IO module identifier

Module-ID 1054

Submodule-ID 1

Description

This module activates the segmentation according to identifier and separator. The parameters specify the identifiers to be searched for, the output mode, and the parameters for the identifier/separator algorithm.

Parameter

Parameter	Description	Addr.	Data type	Value range	Default	Unit
Identifier list						
Identifier 1	The identifier string is used for the identifier list and the filtering according to the segmentation.	0	STRING 5 characters null terminated	1 ... 5 bytes of ASCII characters	""	-
Identifier 2	See identifier 1.	5	STRING 5 characters null terminated	1 ... 5 bytes of ASCII characters	\0	-
Identifier 3	See identifier 1.	10	STRING 5 characters null terminated	1 ... 5 bytes of ASCII characters	\0	-
Identifier 4	See identifier 1.	15	STRING 5 characters null terminated	1 ... 5 bytes of ASCII characters	\0	-
Identifier 5	See identifier 1.	20	STRING 5 characters null terminated	1 ... 5 bytes of ASCII characters	\0	-
Identifier output						
Output with identifier	If this switch is not set, the output of the identifiers is suppressed. Only the data values that belong to the identifiers are displayed in this case.	25.0	Bit	0: Output of the identi- fiers is sup- pressed. 1: Identifiers are output.	1	-
Output delimiter	This delimiter, if not equal to 0, is inserted between the identifier and the associated data value in the output.	26	UNSIGNED8	0 ... 127	0	-
Segmentation acc. to identifier and separator						
Identifier length	Fixed length of all identifiers in the segmentation process. After this length, the text of the identifier ends and the associated data value starts. The end of the data value is determined by the separator.	27	UNSIGNED8	0 ... 255	0	-
Delimiter in the identifier/sepa- rator algorithm	The separator terminates the data value that follows its identifier directly after the identifier length. After the separator, the next identifier starts.	28	UNSIGNED8	0 ... 127	0	-

Table 10.32: Parameters for module 54

Parameter length

29 byte

Input data

None

Output data

None

Identifier string n ($n = 1 \dots 5$)

The identifier string defines both the identifier list for the segmentation and the passthrough filter for the subsequent filtering.

The string may contain wildcards. That is, an arbitrary number of '?' are permitted as placeholders for an arbitrary character at exactly that position.

Also permitted are '*' as placeholders for a character sequence of arbitrary length, and an 'x' if the character at the respective position is to be deleted. There are a total of 5 identifier strings.

An identifier with less than 5 characters must be null terminated. However, if the identifier string consists of exactly 5 characters, it does not have to be null terminated.

**Notice!**

ASCII characters that cannot be displayed (<0x20h) must not be used in the identifier strings.

10.11.4 Module 55 – String handling parameters

PROFINET-IO module identifier

Module-ID 1055

Submodule-ID 1

Description

This module is used to configure placeholder characters for the bar code segmentation, filtering, termination, and reference code processing.

Parameter

Parameter	Description	Addr.	Data type	Value range	Default	Unit
Wildcard character	This parameter is similar to the "don't care character" parameter. The difference between this and the "don't care character" is that all subsequent characters, and not only one character at a certain position, are disregarded until a character pattern is found in the string that follows the wildcard character pattern. This character has the same behavior as the wildcard character for the DIR command in the command line interpreter under Windows.	0	UNSIGNED8	32 ... 126	""	-
Don't care character	Placeholder character. Characters at the position of the placeholder character are ignored in a comparison. This permits certain areas to be masked.	1	UNSIGNED8	32 ... 126	?	-
Delete character	Delete character for bar code and identifier filtering (characters at the position of the delete character are deleted in a comparison. This permits certain areas to be deleted).	2	UNSIGNED8	32 ... 126	'x'	-

Table 10.33: Parameters for module 55

Parameter length

3 byte

Input data

None

Output data

None

10.12 Device Functions

10.12.1 Module 60 – Device status

PROFINET-IO module identifier

Module-ID 1060
Submodule-ID 1

Description

The module contains the display of the device status as well as control bits for triggering a reset or putting the device into standby mode.

Parameter

None

Input data

Input data	Description	Addr.	Data type	Value range	Init value	Unit
Device status	This byte represents the device status.	0	UNSIGNED8	1: Initialisation 10: Standby 11: Service 12: Diagnosis 13: Parameter enabled 15: Device is ready 0x80:Error 0x81:Warning	0	-

Table 10.34: Input data for module 60

Input data length

1 byte

Output data

Output data	Description	Addr.	Data type	Value range	Init value	Unit
System reset	The control bit triggers a system reset ¹⁾ if the level changes from 0 to 1.	0.6	Bit	0: Run 0 -> 1: Reset	0	-
Standby	Activates the standby function .	0.7	Bit	0: Standby off 1: Standby on	0	-

Table 10.35: Output data for module 60

- 1) Analogous to command H, activation of this bit triggers a restart of all electronics, incl. a restart of the PROFINET-IO stack.

Output data length

1 byte



Notice!

When resetting the data (see Module 10 – Activations), the input data of this module is not deleted.

10.12.2 Module 61 – Laser control

PROFINET-IO module identifier

Module-ID 1061

Submodule-ID 1

Description

This module defines the switch-on and switch-off position of the laser.

Parameter

Parameter	Description	Addr.	Data type	Value range	Default	Unit
Laser start position	This parameter defines the switch-on position of the laser in 1/10° increments within the visible range of the laser. The centre of the reading field corresponds to the 0° position.	0 ... 1	UNSIGNED16	-450 ... +450	-450	1/10°
Laser stop position	This parameter defines the switch-off position of the laser in 1/10° increments within the visible range of the laser.	2 ... 3	UNSIGNED16	-450 ... +450	+450	1/10°

Table 10.36: Parameters for module 61

Parameter length

4 byte

Input data

None

Output data

None

10.12.3 Module 63 – Alignment

PROFINET-IO module identifier

Module-ID 1063
 Submodule-ID 1

Description

The module defines input and output data for the alignment mode of the BCL 348*i*. The alignment mode is used for easy alignment of the BCL 348*i* with the bar code. Using the transmitted decoding quality as a percentage, the optimum alignment can be easily selected. This module should not be used in connection with module 81 (AutoReflAct) as this may cause malfunctions.

Parameter

None

Input data

Input data	Description	Addr.	Data type	Value range	Init value	Unit
Decoding quality	Transmits the current decoding quality of the bar code located in the scanning beam.	0	Byte	0 ... 100	0	Percentage

Table 10.37: Input data for module 63

Input data length

1 byte

Output data

Output data	Description	Addr.	Data type	Value range	Init value	Unit
Alignment mode	Signal activates and deactivates the alignment mode for optimum alignment of the BCL 348 <i>i</i> with the bar code.	0.0	Bit	0 -> 1: On 1 -> 0: Off	0	-

Table 10.38: Output data for module 63

Output data length

1 byte

10.12.4 Module 64 – Oscillating mirror

PROFINET-IO module identifier

Module-ID 1064

Submodule-ID 1

Description

Module for supporting the oscillating mirror.

Parameter

Parameter	Description	Addr.	Data type	Value range	Default	Unit
Oscillation mode	This parameter defines the mode in which the oscillating mirror operates.	0	UNSIGNED8	0: Single oscillation 1: Double oscillation 2: Continuous oscillation 3: Continuous oscillation, oscillating mirror moves to the start position at the end of the reading gate.	2	-
Start position	Start position (opening angle) relative to the zero position of the swivel range.	1 ... 2	SIGNED16	-200 ... +200	200	1/10°
Stop position	Stop position (opening angle) relative to the zero position of the swivel range.	3 ... 4	SIGNED16	-200 ... +200	-200	1/10°
Oscillation frequency	Common value for forward and backward motion.	5	UNSIGNED8	15 ... 116	48	%s

Table 10.39: Parameters for module 64

Parameter length

6 byte

Input data

None

Output data

None

10.13 Switching inputs / outputs SWIO 1 ... 2

These modules define the mode of operation of the 2 digital switching inputs and outputs (I/Os). They are separated into individual modules for configuring the individual I/Os and a shared module for signalling the status and controlling all I/Os.

10.13.1 Parameters for operating as an output

Start-up delay

With this setting, the output pulse can be delayed by the specified time (in ms).

Switch-on time

Defines the switch-on time period for the switching input. Any activated switch-off function then no longer has any function.

A value of 0 causes the output to be set statically; this means that the selected input function(s) activate the output, and the selected switch-off function(s) deactivate it again.

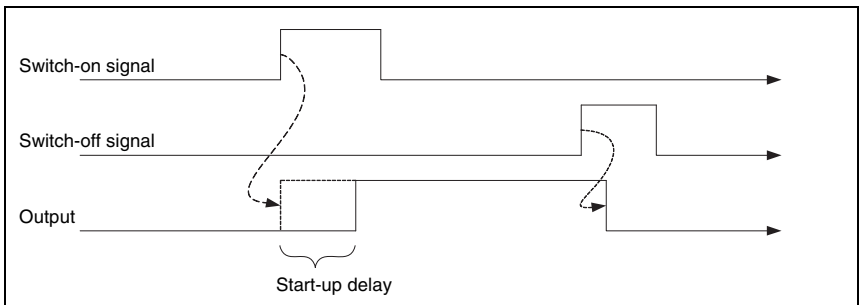

Figure 10.6: Example 1: Start-up delay > 0 and switch-on time = 0

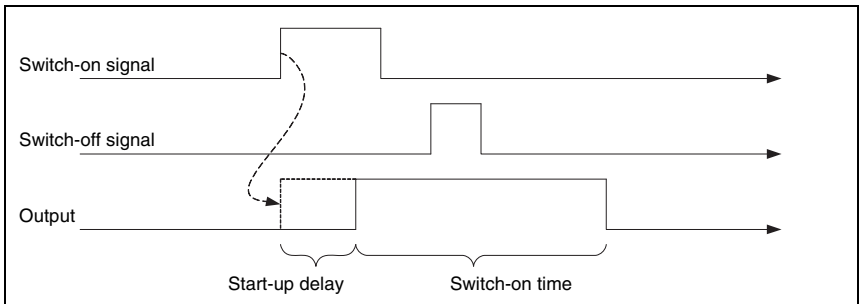

Figure 10.7: Example 2: Start-up delay > 0 and switch-on time > 0

In example 2, the activation duration of the output is only dependent on the selected switch-on time; the switch-off signal has no effect.

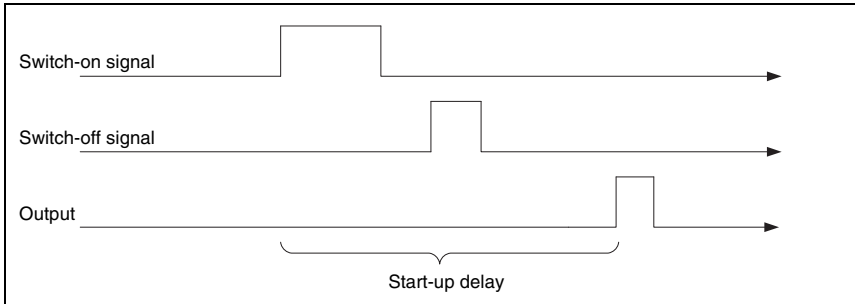

Figure 10.8: Example 3: start-up delay > 0 switch-off signal prior to lapsing of the start-up delay

If the output is again deactivated via the switch-off signal before the start-up delay lapses, only a brief pulse appears at the output following the start-up delay.

Comparison functionality

If, for example, the switching output is to be activated after four invalid read results, the **comparative value** is set to **4** and the **switch-on function** is configured to "invalid read result".

The **comparison mode** parameter can be used to define whether the switching output is activated only once in the case that the event counter and comparative value fulfil the "parity" condition, or if it is activated multiple times, on each successive event after the "parity" condition is met.

The event counter can always be reset with the I/O data in the **I/O status and control** module; furthermore, the **reset mode** parameter enables automatic resetting upon reaching the **comparative value**. Automatic resetting upon reaching the **comparative value** always results in the switching output being switched once independent of the **comparison mode** parameter.

The standard switch-off function at **reading gate start** is rather unsuited for this module since it causes the event counter to be reset on each reading gate start. Suitable as switch-off function for this example is the **valid read result** function; otherwise, all switch-off functions are deactivated.

10.13.2 Parameters for operating as an input

Debounce time

Parameter for setting the software debounce time for the switching input. The definition of a debounce time extends the signal transition time accordingly.

If the value of this parameter = 0, no debouncing takes place; otherwise, the configured value represents the duration in milliseconds for which the input signal must be present and stable.

Start-up delay td_{on}

If the value of this parameter = 0, no start-up delay occurs for the activation of the input function; otherwise, the configured value represents the time in milliseconds by which the input signal is delayed.

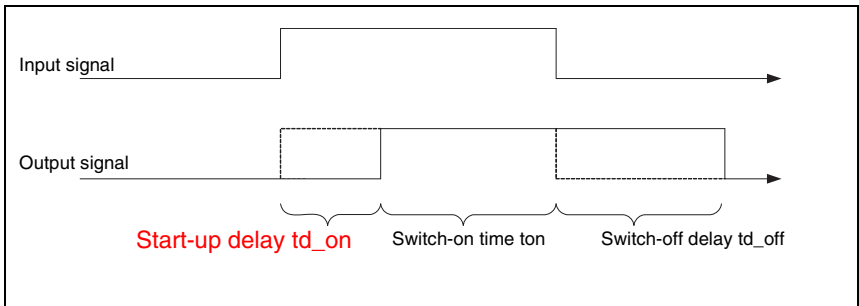

Figure 10.9: Start-up delay in input mode

Switch-on time ton

This parameter specifies the min. activation duration for the selected input function in ms.

The actual activation duration is calculated from the switch-on time as well as the switch-off delay.

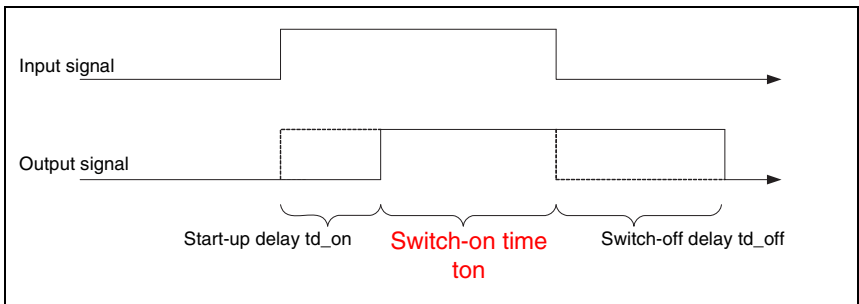

Figure 10.10: Switch-on time in input mode

Switch-off delay *td_off*

This parameter specifies the duration of the switch-off delay in ms.

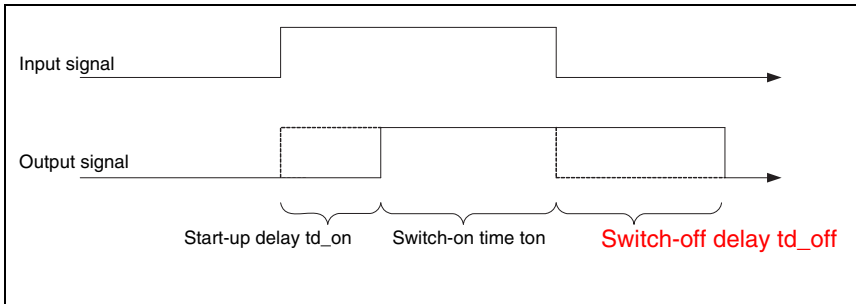

Figure 10.11: Switch-off delay in input mode

10.13.3 Switch-on and switch-off functions for operation as an output

The following options are available for switch-on and switch-off functions in the "output" operating mode:

Name	Value	Comments
No function	0	No functionality.
Reading gate start	1	
Reading gate end	2	
Positive reference code comparison 1	3	
Negative reference code comparison 1	4	
Valid read result	5	
Invalid read result	6	
Device ready	7	The device is in a ready state.
Device not ready	8	The device is not yet ready (motor and laser are being activated).
Data transmission active	9	
Data transmission not active	10	
AutoControl good quality	13	
AutoControl bad quality	14	
Reflector detected	15	
Reflector not detected	16	
External event, pos. edge	17	In the PROFINET case, the external event is generated with the aid of module 74 – "I/O status and control". See "Module 74 – SWIO status and control" on page 161.
External event, neg. edge	18	See above
Device active	19	Decoding is currently being performed.
Device in standby mode	20	Motor and laser inactive.
No device error	21	An error was detected.
Device error	22	Device is in an error state.
Positive reference code comparison 2	23	
Negative reference code comparison 2	24	

Table 10.40: Switch-on/switch-off functions

10.13.4 Input functions for operation as an input

Name	Value	Comments
No function	0	No functionality.
Activation of the reading gate	1	
Reading gate deactivation only	2	
Reading gate activation only	3	
Reference bar code teach-in	4	
Start/stop autoconfiguration mode	5	

Table 10.41: Input functions

10.13.5 Module 70 – Switching input/output SWIO1

PROFINET-IO module identifier

Module-ID 1070

Submodule-ID 1

Parameter

Parameter	Description	Addr.	Data type	Value range	Default	Unit
Function	This parameter defines whether I/O 1 functions as an input or as an output.	0.0	Bit	0: Input 1: Output	0	-
Mode of operation for configuration as an output						
DC bias level	The parameter defines the DC bias level of the switching output and, thus, simultaneously whether the output is low-active (0) or high-active (1).	0.1	Bit	0: LOW (0V) 1: HIGH (+Ub)	0	-
Reserved	Free	0.2 ... 0.7				
Start-up delay	With this parameter, the output pulse may be delayed by a set time period.	1	UNSIGNED16	0 ... 65535	0	ms
Switch-on time	The parameter defines the switch-on time period for the switching output. If the value is 0, the signal is static.	3	UNSIGNED16	0 ... 1300	400	ms
Switch-on function 1	This parameter specifies an event which can set the switching output.	5	UNSIGNED8	cf. "Switch-on/switch-off functions" on page 156	0	-
Switch-on function 2	This parameter specifies an event which can set the switching output. Switch-on function 1 and switch-on function 2 are OR linked.	6	UNSIGNED8	cf. "Switch-on/switch-off functions" on page 156	0	-
Switch-off function 1	This parameter specifies an event which can reset the switching output.	7	UNSIGNED8	cf. "Switch-on/switch-off functions" on page 156	0	-
Switch-off function 2	This parameter specifies an event which can reset the switching output. Switch-off function 1 and switch-off function 2 are OR linked.	8	UNSIGNED8	cf. "Switch-on/switch-off functions" on page 156	0	-

Table 10.42: Parameters for module 70 – Input/Output 1

Parameter	Description	Addr.	Data type	Value range	Default	Unit
Comparative value (Event Counter)	If the number of activation events of the selected switch-on function reaches this comparative value, the switching output is activated. A deactivation event of the selected switch-off function resets the counter.	9	UNSIGNED16	0..65535	0	-
Compare mode (Event Counter)	Specifies whether the switching output switches only on parity (once) or also in the event of greater or equal to (multiple times) after the comparative value is reached.	11	UNSIGNED8	0: SWOUT switches once 1: SWOUT switches several times	0	-
Reset mode (Event Counter)	Specifies whether the counter (Event Counter) is reset only by the reset bit and the selected switch-off function, or if the counter should be automatically reset after the comparative value is reached.	12	UNSIGNED8	0: Reset bit and switch-off funct. 1: Comparative value reached	0	-
Mode of operation for configuration as an input						
Inversion	The parameter defines the logic of the incident signal. In case of an inversion, an external HIGH level is interpreted internally as a LOW level.	13.1	Bit	0: Normal 1: Inverted	0	-
Reserved	Free	13.2 ... 13.7				
Debounce time	The parameter defines a debounce time which is implemented in software.	14	UNSIGNED16	0 ... 1000	5	ms
Start-up delay	The parameter influences the timing during switch-on.	16	UNSIGNED16	0 ... 65535	0	ms
Minimum switch-on time	The parameter defines a minimum time period before the signal is reset.	18	UNSIGNED16	0 ... 65535	0	ms
Switch-off delay	The parameter defines a time delay for the signal during switch-off.	20	UNSIGNED16	0 ... 65535	0	ms
Input function	The parameter specifies the function which is to be activated or deactivated by a change of state in the signal.	22	UNSIGNED8	cf. "Input functions" on page 157	1	-

Table 10.42: Parameters for module 70 – Input/Output 1

Parameter length

23 byte

Input data

None

Output data

None

Remark

The DC bias level also defines whether the output is low-active (0) or high-active (1). Switching on an I/O configured as an output means switching to the active state; switching off, on the other hand, results in switching to the inactive or idle state.

10.13.6 Module 71 – Switching input/output SWIO2

PROFINET-IO module identifier

Module-ID 1071

Submodule-ID 1

Parameter

Parameter	Description	Addr.	Data type	Value range	Default	Unit
Function	This parameter defines whether I/O 2 functions as an input or as an output.	0.0	Bit	0: Input 1: Output	1	-
Mode of operation for configuration as an output						
DC bias level	The parameter defines the DC bias level of the switching output and, thus, simultaneously whether the output is low-active (0) or high-active (1).	0.1	Bit	0: LOW (0V) 1: HIGH (+Ub)	0	-
Reserved	Free	0.2 ... 0.7				
Start-up delay	With this parameter, the output pulse may be delayed by a set time period.	1	UNSIGNED16	0 ... 65535	0	ms
Switch-on time	The parameter defines the switch-on time period for the switching output. If the value is 0, the signal is static.	3	UNSIGNED16	0 ... 1300	400	ms
Switch-on function 1	This parameter specifies an event which can set the switching output.	5	UNSIGNED8	cf. "Switch-on/switch-off functions" on page 156	5	-
Switch-on function 2	This parameter specifies an event which can set the switching output. Switch-on function 1 and switch-on function 2 are OR linked.	6	UNSIGNED8	cf. "Switch-on/switch-off functions" on page 156	0	-
Switch-off function 1	This parameter specifies an event which can reset the switching output.	7	UNSIGNED8	cf. "Switch-on/switch-off functions" on page 156	1	-
Switch-off function 2	This parameter specifies an event which can reset the switching output. Switch-off function 1 and switch-off function 2 are OR linked.	8	UNSIGNED8	cf. "Switch-on/switch-off functions" on page 156	0	-
Comparative value (Event Counter)	If the number of activation events of the selected switch-on function reaches this comparative value, the switching output is activated. A deactivation event of the selected switch-off function resets the counter.	9	UNSIGNED16	0..65535	0	-
Compare mode (Event Counter)	Specifies whether the switching output switches only on parity (once) or also in the event of greater or equal to (multiple times) after the comparative value is reached.	11	UNSIGNED8	0: SWOUT switches once 1: SWOUT switches several times	0	-

Table 10.43: Parameters for module 71 – Input/Output 2

Parameter	Description	Addr.	Data type	Value range	Default	Unit
Reset mode (Event Counter)	Specifies whether the counter (Event Counter) is reset only by the reset bit and the selected switch-off function, or if the counter should be automatically reset after the comparative value is reached.	12	UNSIGNED8	0: Reset bit and switch-off funct. 1: Comparative value reached	0	-
Mode of operation for configuration as an input						
Inversion	The parameter defines the logic of the incident signal. In case of an inversion, an external HIGH level is interpreted internally as a LOW level.	13.1	Bit	0: Normal 1: Inverted	0	-
Reserved	Free	13.2 ... 13.7				
Debounce time	The parameter defines a debounce time which is implemented in software.	14	UNSIGNED16	0 ... 1000	5	ms
Start-up delay	The parameter influences the timing during switch-on.	16	UNSIGNED16	0 ... 65535	0	ms
Minimum switch-on time	The parameter defines a minimum time period before the signal is reset.	18	UNSIGNED16	0 ... 65535	0	ms
Switch-off delay	The parameter defines a time delay for the signal during switch-off.	20	UNSIGNED16	0 ... 65535	0	ms
Input function	The parameter specifies the function which is to be activated or deactivated by a change of state in the signal.	22	UNSIGNED8	cf. "Input functions" on page 157	0	-

Table 10.43: Parameters for module 71 – Input/Output 2

Parameter length

23 byte

Input data

None

Output data

None

Remark

The DC bias level also defines whether the output is low-active (0) or high-active (1).

Switching on an I/O configured as an output means switching to the active state; switching off, on the other hand, results in switching to the inactive or idle state.

10.13.7 Module 74 – SWIO status and control

PROFINET-IO module identifier

Module-ID 1074
 Submodule-ID 1

Description

Module for handling switching input and switching output signals.

Parameter

None

Input data

Input data	Description	Addr.	Data type	Value range	Init value	Unit
State 1	Signal state of switching input or output 1.	0.0	Bit	0.1	0	-
State 2	Signal state of switching input or output 2.	0.1	Bit	0.1	0	-
Comparison state switching output 1 (Event Counter)	Indicates whether the event counter has exceeded the set comparative value. The bit is reset to the init. value by resetting the event counter.	1.0	Bit	0: Not exceeded 1: Exceeded	0	-
Switching output 1 Comparison state toggle bit (Event Counter)	If "SWOUT switches several times" was configured as comparison mode, this bit is toggled each time the event counter is exceeded. The bit is reset to the init. value by resetting the event counter.	1.1	Bit	0 → 1: Event counter exceeded 1 → 0: Event counter exceeded again	0	-
Comparison state switching output 2 (Event Counter)	Indicates whether the event counter has exceeded the set comparative value. The bit is reset to the init. value by resetting the event counter.	1.2	Bit	0: Not exceeded 1: Exceeded	0	-
Switching output 2 Comparison state toggle bit (Event Counter)	If "SWOUT switches several times" was configured as comparison mode, this bit is toggled each time the event counter is exceeded. The bit is reset to the init. value by resetting the event counter.	1.3	Bit	0 → 1: Event counter exceeded 1 → 0: Event counter exceeded again	0	-

Table 10.44: Input data for module 74 Input/output status and control

Input data length

2 bytes

Output data

Output data	Description	Addr.	Data type	Value range	Init value	Unit
Switching output 1	Sets the state of switching output 1.	0.0	Bit	0: Switching output 0 1: Switching output 1	0	-
Switching output 2	Sets the state of switching output 2.	0.1	Bit	0: Switching output 0 1: Switching output 1	0	-
Reset Event Counter Switching output 1	Sets the event counter of the activation function [AF] for switching output 1 back to zero.	0.4	Bit	0 -> 1: Perform reset 1 -> 0: No function	0	-
Reset Event Counter Switching output 2	Sets the event counter of the activation function [AF] for switching output 2 back to zero.	0.5	Bit	0 -> 1: Perform reset 1 -> 0: No function	0	-
	Reserved	1	Byte			

Table 10.45: Output data for module 74 Input/output status and control

Output data length

2 bytes

10.14 Data output

10.14.1 Module 80 – Sorting

PROFINET-IO module identifier

Module-ID 1080

Submodule-ID 1

Description

Module to support the sorting of the output data.

Parameter

Parameter	Description	Addr.	Data type	Value range	Default	Unit
Sort criterion 1	Specifies the criterion according to which sorting takes place.	0.0 ... 0.6	BitArea	0: No sorting 1: Sorting according to scan number 2: Sorting according to position in the scanning beam 3: Sorting according to the oscillating mirror position 4: Sorting according to the decoding quality 5: Sorting according to the bar code length 6: Sorting according to the code type number 7: Sorting according to the decoding direction 8: Sorting according to the bar code content 9: Sorting according to time 10: Sorting according to scanning duration 11: Sorting according to the code list (in which the enabled bar codes are listed) 12: Sorting according to the identifier list	0	-
Sort direction 1	Specifies the sorting direction.	0.7	Bit	0: In ascending order 1: In descending order	0	-
Sort criterion 2	Specifies the criterion according to which sorting takes place.	1.0 ... 1.6	BitArea	See sorting criterion 1	0	-
Sort direction 2	Specifies the sorting direction.	1.7	Bit	See sorting direction 1	0	-
Sort criterion 3	Specifies the criterion according to which sorting takes place.	2.0 ... 2.6	BitArea	See sorting criterion 1	0	-
Sort direction 3	Specifies the sorting direction.	2.7	Bit	See sorting direction 1	0	-

Table 10.46: Parameters for module 80

Parameter length

3 byte

Input data

None

Output data

None

10.15 Reference code comparison

The following modules can be used to support reference code comparison.

The reference code function compares the currently decoded read results with one or more stored comparison patterns. The function is split into two comparison units which can be configured independently of each other.

10.15.1 Module 81 – Reference code comparator 1

PROFINET-IO module identifier

Module-ID 1081

Submodule-ID 1

Description

The module defines the mode of operation of reference code comparator 1.

Parameter

Parameter	Description	Addr.	Data type	Value range	Default	Unit
Output function after reference bar code comparison	This parameter specifies the associated output linkage after a reference bar code comparison.	0	UNSIGNED8	0: No function 1: Comparison function 1 2: Comparison function 2 3: Comparison function 1 and 2 4: Comparison function 1 OR 2	1	-
Linking logic for reference code output signal	This parameter specifies the linking logic for the reference code output signal.	1	UNSIGNED8	0: Length and type and ASCII 1: Length and (type or ASCII) 2: (Length or type) and ASCII 3: Length or type or ASCII	0	-
Output for reference code comparison	This parameter specifies whether a bar code length comparison should be carried out.	2	UNSIGNED8	0: Length ignored 1: Comparison o.k. if length not identical 2: Comparison o.k. if length identical.	2	-
Bar code type comparison	This parameter specifies whether a bar code type comparison should be carried out.	3	UNSIGNED8	0: Type ignored 1: Comparison o.k. if types not identical 2: Comparison o.k. if types identical.	2	-
Reference code ASCII comparison	This parameter specifies how the ASCII comparison should be carried out.	4	UNSIGNED8	0: No comparison 1: Bar code not identical to RC 2: Bar code identical to RC 3: Bar code greater than RC 4: Bar code greater than or equal to RC 5: Bar code less than RC 6: Bar code less than or equal to RC 7: RC1 less than or equal to bar code less than or equal to RC2 8: Bar code less than RC1 or bar code greater than RC2	2	-

Table 10.47: Parameters for module 81 – Reference code comparison

Parameter	Description	Addr.	Data type	Value range	Default	Unit
Reference code comparison mode	This parameter determines how and which reference bar codes (RC) are to be used for the bar code comparison.	5	UNSIGNED8	0: Only the first RC is used for the comparison. 1: Only the second RC is used for the comparison. 2: RC 1 and 2 are used for the comparison. Both conditions for RC 1 and 2 must be satisfied for a positive comparison. 3: RC 1 and 2 are used for the comparison. One of the two conditions for reference bar codes 1 and 2 must be satisfied.	0	-
Bar code comparison mode	This parameter specifies which decoded bar codes are to be used for the reference bar code comparison.	6	UNSIGNED8	0: Only the first bar code is used for the comparison. 1: Only the second bar code is used for the comparison. 2: All bar codes are used for the comparison. All comparisons must be successful. 3: All bar codes are used for the comparison. One comparison must be successful.	3	-
Reference code completeness comparison	If this parameter is set, the basic condition for a positive reference code comparison is that all mandatory bar codes that are to be read within a reading gate were actually read. If this condition is not satisfied, no positive reference code comparison is achieved.	7.0	Bit	0: Completeness comparison switched off. 1: Completeness comparison switched on.	0	-

Table 10.47: Parameters for module 81 – Reference code comparison

Parameter length

8 byte

Input data

None

Output data

None

10.15.2 Module 82 – Reference code comparator 2

PROFINET-IO module identifier

Module-ID 1082

Submodule-ID 1

Description

The module defines the mode of operation of reference code comparator 2.

Parameter

Parameter	Description	Addr.	Data type	Value range	Default	Unit
Output function after reference bar code comparison	This parameter specifies the associated output linkage after a reference bar code comparison.	0	UNSIGNED8	0: No function 1: Comparison function 1 2: Comparison function 2 3: Comparison function 1 and 2 4: Comparison function 1 OR 2	1	-
Linking logic for reference code output signal	This parameter specifies the linking logic for the reference code output signal.	1	UNSIGNED8	0: Length and type and ASCII 1: Length and (type or ASCII) 2: (Length or type) and ASCII 3: Length or type or ASCII	0	-
Output for reference code comparison	This parameter specifies whether a bar code length comparison should be carried out.	2	UNSIGNED8	0: Length ignored 1: Comparison o.k. if length not identical 2: Comparison o.k. if length identical.	2	-
Bar code type comparison	This parameter specifies whether a bar code type comparison should be carried out.	3	UNSIGNED8	0: Type ignored 1: Comparison o.k. if types not identical 2: Comparison o.k. if types identical.	2	-
Reference code ASCII comparison	This parameter specifies how the ASCII comparison should be carried out.	4	UNSIGNED8	0: No comparison 1: Bar code not identical to RC 2: Bar code identical to RC 3: Bar code greater than RC 4: Bar code greater than or equal to RC 5: Bar code less than RC 6: Bar code less than or equal to RC 7: RC1 less than or equal to bar code less than or equal to RC2 8: Bar code less than RC1 or bar code greater than RC2	2	-

Table 10.48: Parameters for module 82 – Reference code comparison

Parameter	Description	Addr.	Data type	Value range	Default	Unit
Reference code comparison mode	This parameter determines how and which reference bar codes (RC) are to be used for the bar code comparison.	5	UNSIGNED8	0: Only the first RC is used for the comparison. 1: Only the second RC is used for the comparison. 2: RC 1 and 2 are used for the comparison. Both conditions for RC 1 and 2 must be satisfied for a positive comparison. 3: RC 1 and 2 are used for the comparison. One of the two conditions for reference bar codes 1 and 2 must be satisfied.	0	-
Bar code comparison mode	This parameter specifies which decoded bar codes are to be used for the reference bar code comparison.	6	UNSIGNED8	0: Only the first bar code is used for the comparison. 1: Only the second bar code is used for the comparison. 2: All bar codes are used for the comparison. All comparisons must be successful. 3: All bar codes are used for the comparison. One comparison must be successful.	3	-
Reference code completeness comparison	If this parameter is set, the basic condition for a positive reference code comparison is that all mandatory bar codes that are to be read within a reading gate were actually read. If this condition is not satisfied, no positive reference code comparison is achieved.	7.0	Bit	0: Completeness comparison switched off. 1: Completeness comparison switched on.	0	-

Table 10.48: Parameters for module 82 – Reference code comparison

Parameter length

8 byte

Input data

None

Output data

None

10.15.3 Module 83 – Reference code comparison pattern 1

PROFINET-IO module identifier

Module-ID 1083

Submodule-ID 1

Description

This module can be used to define the 1st comparison pattern

Parameter

Parameter	Description	Addr.	Data type	Value range	Default	Unit
Code type comparison pattern 1	Specifies the type of the reference bar code.	0	UNSIGNED8	0: No code 1: 2/5 Interleaved 2: Code39 3: Code32 6: UPC, UPCE 7: EAN8, EAN13 8: Code128 10: EAN Addendum 11: Codabar 12: Code93 13: GS1 DataBar Omnidirectional 14: GS1 DataBar Limited 15: GS1 DataBar Omnidirectional Expanded	0	-
Comparison pattern 1	Parameter string describing the content of the reference bar code. Note: You can also use the two placeholder characters that are stored in the "Wildcard character" and "Don't care character" parameters. If the string is empty, no comparison takes place. If the most recently stored character is the wildcard character, the comparison is only carried out up to the character before this wildcard character. In this way it is possible to switch off a comparison according to bar code length.	1	STRING 30 characters null terminated	1 ... 30 bytes of ASCII characters	\00	-

Table 10.49: Parameter module 83 – Reference code comparison pattern

Parameter length

31 byte

Input data

None

Output data

None



Notice!

The defined comparison pattern affects both reference code comparators (Module 81 – Reference code comparator 1 and Module 82 – Reference code comparator 2).

ASCII characters that cannot be displayed (<0x20h) must not be used in the comparison pattern.

10.15.4 Module 84 – Reference code comparison pattern 2

PROFINET-IO module identifier

Module-ID 1084
 Submodule-ID 1

Description

This module can be used to define the 2nd comparison pattern

Parameter

Parameter	Description	Addr.	Data type	Value range	Default	Unit
Code type comparison pattern 2	Specifies the type of the reference bar code.	0	UNSIGNED8	0: No code 1: 2/5 Interleaved 2: Code39 3: Code32 6: UPC, UPCE 7: EAN8, EAN13 8: Code128 10: EAN Addendum 11: Codabar 12: Code93 13: GS1 DataBar Omnidirectional 14: GS1 DataBar Limited 15: GS1 DataBar Expanded	0	-
Comparison pattern 2	Parameter string describing the content of the reference bar code. Note: You can also use the two placeholder characters that are stored in the "Wildcard character" and "Don't care character" parameters. If the string is empty, no comparison takes place. If the most recently stored character is the wildcard character, the comparison is only carried out up to the character before this wildcard character. In this way it is possible to switch off a comparison according to bar code length.	1	STRING 30 characters null terminated	1 ... 30 bytes of ASCII characters	\00	-

Table 10.50: Parameter module 84 – Reference code comparison pattern

Parameter length

31 byte

Input data

None

Output data

None



Notice!

The defined comparison pattern affects both reference code comparators (Module 81 – Reference code comparator 1 and Module 82 – Reference code comparator 2). ASCII characters that cannot be displayed (<0x20h) must not be used in the comparison pattern.

10.16 Special Functions

10.16.1 Module 90 – Status and control

PROFINET-IO module identifier

Module-ID 1090

Submodule-ID 1

This module supplies various BCL 348*i* status information to the PROFINET-IO master. Various functions of the BCL 348*i* can be controlled via the master's output data.

Parameter

None

Input data

Input data	Description	Addr.	Data type	Value range	Init value	Unit
Reserved	Free	0.0	Bit		0	-
AutoRefl state	Signal state of the AutoRefl module	0.1	Bit	0: Reflector is recognised 1: Reflector is hidden	1	-
Auto Control result	Indicates whether the result of the AutoControl function was a good or bad reading.	0.2	Bit	0: Quality good 1: Quality bad	0	-
Reserved	Free	0.3	Bit		0	-
RefCode comparison state 1	The signal indicates whether the decoded bar code corresponds to the reference code with regard to the comparison criteria as defined in the comparison function 1. If it matches, the value 1 is output.	0.4 ... 0.5	Bit	0: Not equal 1: Equal 2: Unknown	2	-
RefCode comparison state 2	The signal indicates whether the decoded bar code corresponds to the reference code with regard to the comparison criteria as defined in the comparison function 2. If it matches, the value 1 is output.	0.6 ... 0.7	Bit	0: Not equal 1: Equal 2: Unknown	2	-

Table 10.51: Input data for module 90 – Status and control

Input data length

1 byte

Output data

None

10.16.2 Module 91 – AutoReflAct (automatic reflector activation)

PROFINET-IO module identifier

Module-ID 1091
 Submodule-ID 1

Description

The module defines the mode of operation of the laser scanner for controlling the reading gate.

The AutoReflAct function uses the scanning beam to simulate a photoelectric sensor and thus permits an activation without additional sensory mechanism. This is achieved by directing the scanner with reduced scanning beam towards a reflector mounted behind the conveyor path. As long as the scanner is targeted at the reflector, the reading gate remains closed. If, however, the reflector is blocked by an object such as a container with a bar code label, the scanner activates the read procedure, and the label on the container is read. When the path from the scanner to the reflector has cleared, the read procedure has completed and the scanning beam is reduced and again directed onto the reflector. The reading gate is closed.

Parameter

Parameter	Description	Addr.	Data type	Value range	Default	Unit
Mode	This parameter activates the function of the laser scanner. If "Autom. reading gate control" is set as the parameter value, the BCL activates the reading gate automatically if the reflector is obscured.	0	UNSIGNED8	0: Normal AutoreflAct switched off. 1: Auto AutoreflAct activated. Autom. reading gate control. 2: Manual AutoreflAct activated. No reading gate control, signalling only.	0	-
Debouncing	The parameter defines the debounce time in scans for the reflector detection. With a motor speed of 1000, 1 scan corresponds to a debounce time of 1ms.	1	UNSIGNED8	1 ... 16	5	-

Table 10.52: Parameters for module 91 – AutoreflAct

Parameter length

2 bytes

Input data

None

Output data

None

10.16.3 Module 92 – AutoControl

PROFINET-IO module identifier

Module-ID 1092

Submodule-ID 1

Description

The module defines the mode of operation of the function AutoControl. The function monitors the quality of the decoded bar codes and compares these with a limit value. If the limit is reached, a status is set.

Parameter

Parameter	Description	Addr.	Data type	Value range	Default	Unit
AutoControl enable	This parameter can be used to activate or deactivate the AutoControl function.	0	UNSIGNED8	0: deactivated 1: activated	0	-
Limit for reading quality	The parameter defines a threshold for the reading quality.	1	UNSIGNED8	0 ... 100	50	%
Sensitivity	With this parameter the sensitivity towards changes in the reading ability can be specified. The higher the value, the less influence a change of reading ability has.	2	UNSIGNED8	0 ... 255	0	-

Table 10.53: Parameters for module 92 – AutoControl

Parameter length

3 byte

Input data

Input data	Description	Addr.	Data type	Value range	Init value	Unit
Scan quality	Represents the current average value of the scan quality (at the time of the last reading gate).	0	UNSIGNED8	0 ... 100	0	-

Table 10.54: Input data for module 92 – AutoControl

Input data length

1 byte

Output data

None

Notice:

By means of the AutoControl function, it is possible to detect bar codes of decreasing quality and thus take appropriate measures before the label is no longer legible. With activated AutoControl function, note that the "Processing end at end of label" parameter in the CRT module should be set to allow for a better assessment of the bar code quality (see also "Module 7 – Code fragment technology" on page 119).

10.17 Example configuration: Indirect activation via the PLC

10.17.1 Task

- Reading of a 10-digit code in 2/5 Interleaved format
- Indirect activation of the BCL 348*i* via the PLC

Code sample

Code 2/5 Interleaved 10 digits with check digit

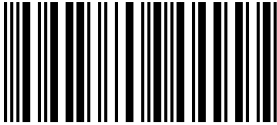

2234234459

10.17.2 Procedure

Hardware, connections

The following connections must have been established:

- Voltage supply (PWR)
- PROFINET-IO (HOST/BUS) In

Required modules

Include the following modules in your project:

- Module 1010 – Activations
- Module 1023 – Decoding result 12 bytes

Parameter settings

No parameters need to be set separately. The standard parameter set provides all required functions.

Flow diagrams

Successful reading:

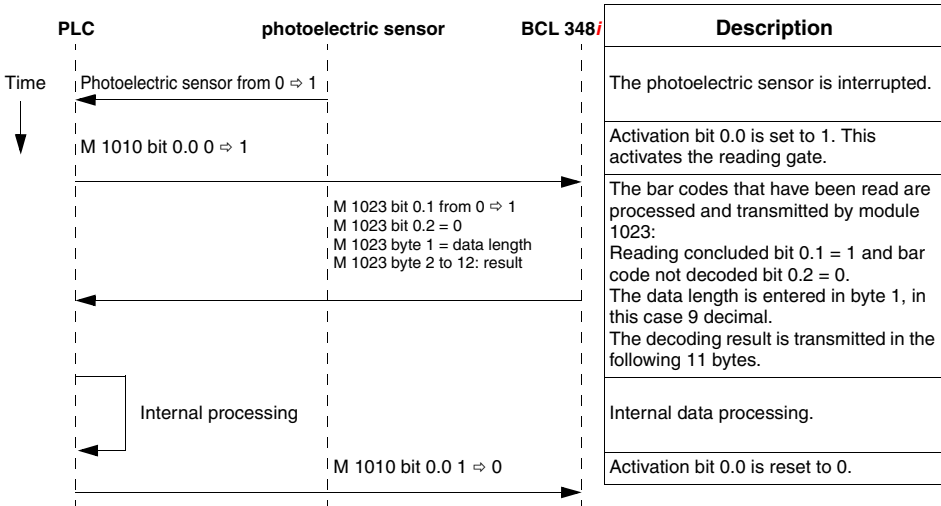

Unsuccessful reading:

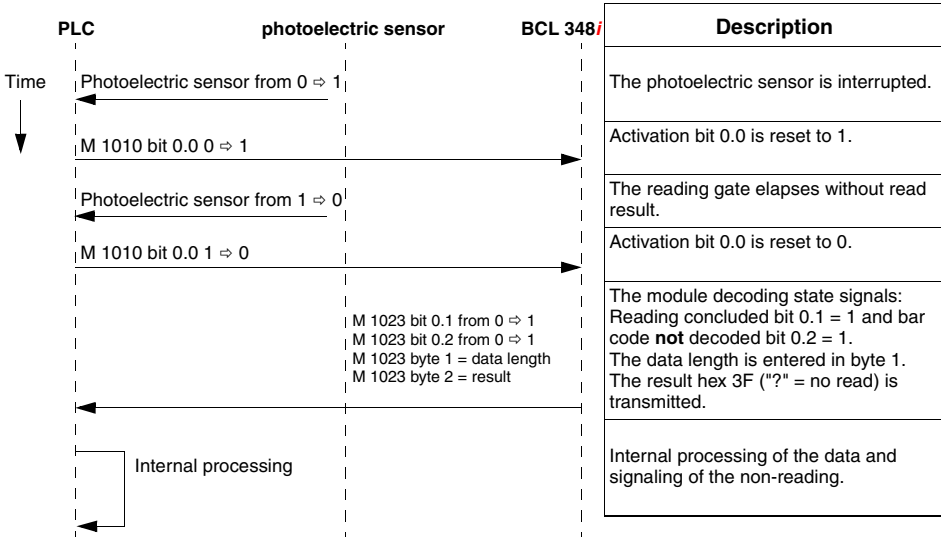

10.18 Sample configuration: Direct activation via the switching input

10.18.1 Task

- Reading of a 12-digit bar code in 2/5 Interleaved format
- Direct activation of the BCL 348*i* via a photoelectric sensor

Code sample

Code 2/5 Interleaved 12 digits with check digit

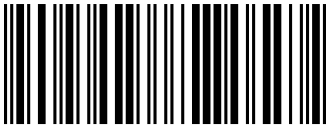

561234765436

10.18.2 Procedure

Hardware, connections

The following connections must have been established:

- Voltage supply (PWR)
- PROFINET-IO (HOST/BUS) In
- Photoelectric sensor at SWIO1

Required modules

Include the following modules in your project:

- Module 1023 – Decoding result 12 bytes

Parameter settings of the "device parameters"

Byte	Description	Init value	Change value to:
1	Code type 1	0	01: 2/5 Interleaved
4	Digits 3	0	12

Table 10.55: Device parameters for example configuration 2

Flow diagrams

Successful reading:

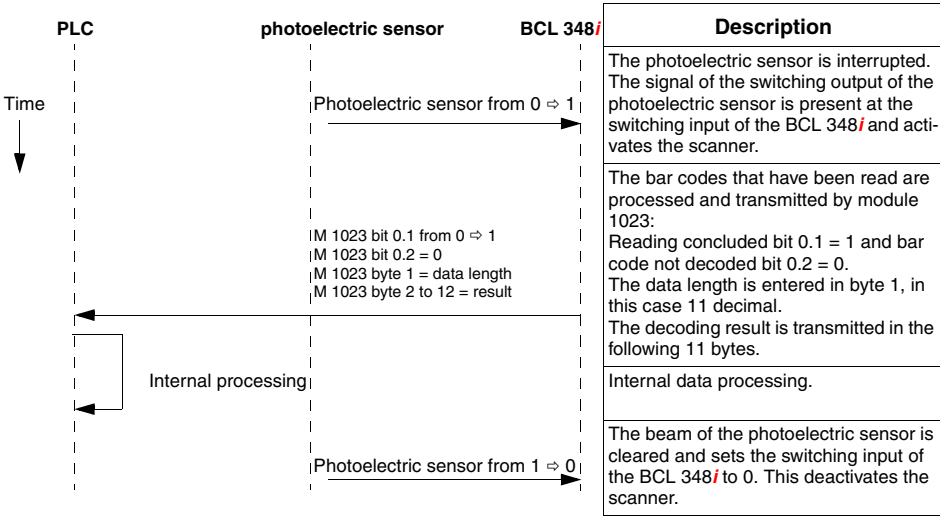

Unsuccessful reading:

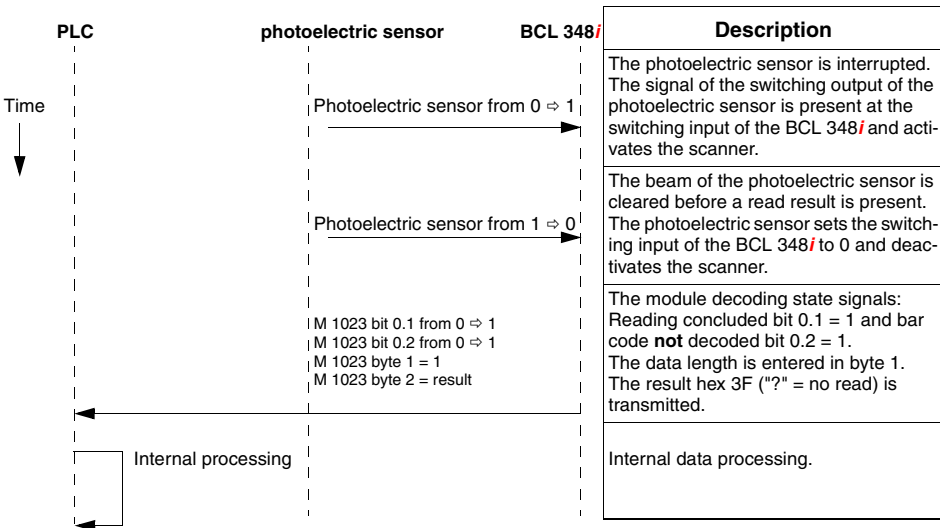

10.19 Sample configuration: Indirect activation via the switching input

10.19.1 Task

- Reading of a 10-digit bar code only in 2/5 Interleaved format
- Indirect activation of the BCL 348*i* via PLC and photoelectric sensor
- Setting and transmission of a check digit
- Information regarding "Number of scans with information" is needed in the PLC
- Data transmission after the end of the reading gate

Code sample

Code 2/5 Interleaved 10 digits with check digit

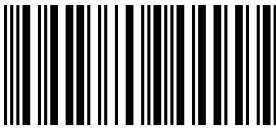

2234234459

10.19.2 Procedure

Hardware, connections

The following connections must have been established:

- Voltage supply (PWR)
- PROFIBUS In
- PROFIBUS termination
- Photoelectric sensor to SW IN

Required modules

Include the following modules in your project:

- Module 10 – Activations
- Modules 21-27 – Decoding result
- Module 36 – Scans with information
- Modules 1-4 – Code table extensions 1 to 4, activate check digit calculation and output
- Module 70/71 – activate switching input
- Module 11 – Reading gate control

Parameter settings

Byte	Description	Init value	Change value to:
5	[T2] Code type	Code 39	0 (no code)
9	[T3] Code type	EAN8, EAN13	0 (no code)
13	[T4] Code type	Code 128	0 (no code)

Table 10.56: Device parameters for example configuration 3

Module	Byte	Description	Init value	Change value to:
Module 11	2	Reading gate end mode	1 (dependent on decoding)	0 (independent)
Module 1-4	2	Check digit monitoring 2/5 Interleaved	0 (no check)	1 (check)
Module 1-4	4	Check digit transmission 2/5 Interleaved	0 (no output)	1 (output)
Module 70/71	10	Function	1 (reading gate activation)	0 (no function)

Table 10.57: Module parameters for example configuration 3

Flow diagrams

Successful reading/unsuccessful reading:

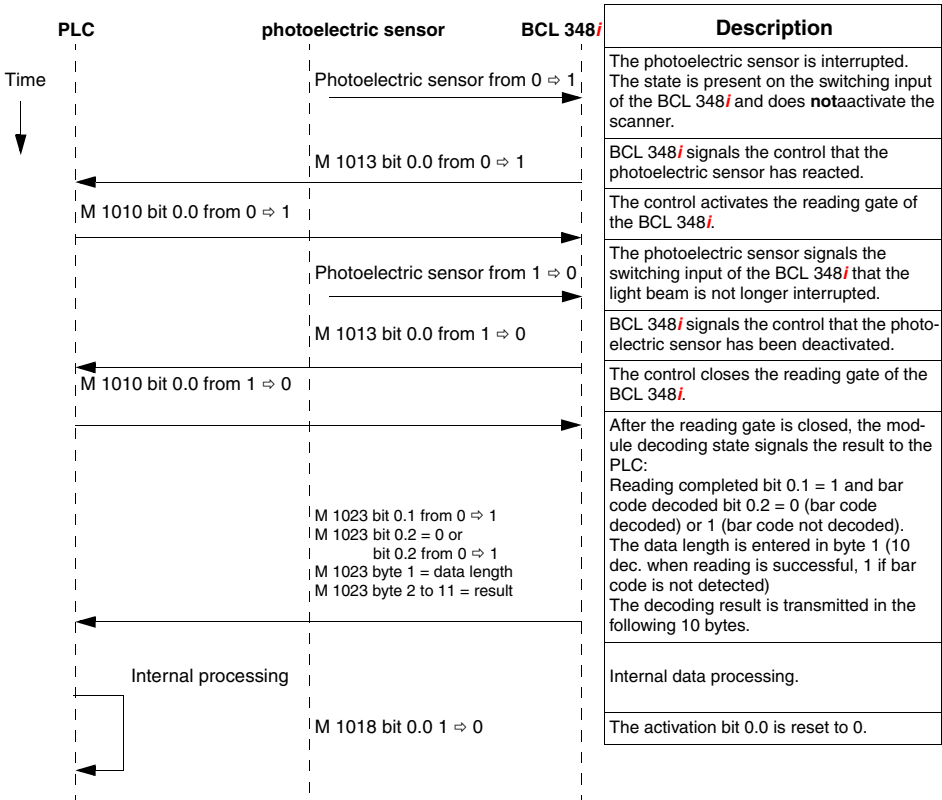

11 Online commands

11.1 Overview of commands and parameters

Online commands can be used to send commands directly to the device for control and configuration.

For this purpose, the BCL 348*i* must be connected to a host- or service computer via the interface. The commands described can be sent either via the host or the service interface.

Online commands

With the commands, you can:

- control/decode.
- read/write/copy parameters.
- carry out an automatic configuration.
- teach-in/set reference codes.
- call up error messages.
- call up statistical device information.
- carry out a software reset in order to reinitialize the device.

Syntax

"Online" commands consist of one or two ASCII characters followed by command parameters.

No separation characters may be entered between the command and the command parameter(s). Both small and capitalized letters can be used.

Example:

Command '**CA**': autoConfig function

Parameter '+': Activation

Transmitted is: '**CA+**'

Notation

Commands, command parameters and returned data are enclosed between single quotation marks ' ' in the text of this manual.

Most online commands are acknowledged by the BCL 348*i* and any requested data returned. For commands that are not acknowledged, command execution can be observed or monitored directly on the device.

11.1.1 General 'online' commands

Software version number

Command	'V'
Description	Requests device version information
Parameter	no
Acknowledgment	The first line contains the device type of the BCL 348 <i>i</i> , followed by the device version number and version date. (The data which is actually displayed may vary from the values given here.)



Notice!

This command returns the major release number of the software packet. This major release number also appears on the display during start-up.

This command can be used to check whether the connected host or service computer is properly connected and configured. If you do not receive an acknowledgment, please check interface connections, protocol and service switches.

Software reset

Command	'H'
Description	Carries out a software reset. The device is restarted and reinitialized, leaving it in the same state as when the supply voltage is switched on.
Parameter	no
Acknowledgment	'S' (start signal)

Code recognition

Command	'CC'
Description	Detects an unknown bar code and outputs number of digits, code type, and code information to the interface, without storing the bar code in the parameter memory.
Parameter	no
Acknowledgment	<p>'xx yy zzzzzz'</p> <p>xx: Code type of the read code</p> <p>'01' 2/5 Interleaved</p> <p>'02' Code 39</p> <p>'03' Code 32</p> <p>'06' UPC (A, E)</p> <p>'07' EAN</p> <p>'08' Code 128, EAN 128</p> <p>'10' EAN Addendum</p> <p>'11' Codabar</p> <p>'12' Code 93</p> <p>'13' GS1 DataBar OMNIDIRECTIONAL</p> <p>'14' GS1 DataBar LIMITED</p> <p>'15' GS1 DataBar EXPANDED</p> <p>yy: Number of digits of the read code</p> <p>zzzzzz: Contents of the decoded label. A ↑ appears if the label was not correctly read.</p>

autoConfig

Command	'CA'
Description	Activates or deactivates the 'autoConfig' function. BCL 348 <i>i</i> Certain label reading parameters are programmed automatically in the setup by the labels which are read while the 'autoConfig' function is active.
Parameter	'+' Activates 'autoConfig' '/' Rejects the last code read '-' Deactivates 'autoConfig' and stores the decoded data in the current parameter set.
Acknowledgment	'CSx' x Status '0' Valid 'CA' command '1' Invalid command '2' autoConfig could not be activated '3' autoConfig could not be deactivated '4' Result could not be deleted
Description	'xx yy zzzzzz' xx No. of digits of the read code yy Code type of the read code '01' 2/5 Interleaved '02' Code 39 '03' Code 32 '06' UPC (A, E) '07' EAN '08' Code 128, EAN 128 '10' EAN Addendum '11' Codabar '12' Code 93 '13' GS1 DataBar OMNIDIRECTIONAL '14' GS1 DataBar LIMITED '15' GS1 DataBar EXPANDED zzzzz: Contents of the decoded label. A ↑ appears if the label was not correctly read.

Alignment mode

Command	'JP'
Description	<p>This command simplifies mounting and alignment of the BCL 348<i>i</i>. After activating the function with 'JP+', the BCL 348<i>i</i> continuously supplies status information to the serial interfaces. With this online command, the scanner is set to terminate the decoding after 100 successfully decoded labels and output the status information. Subsequently, the read process is reactivated automatically. In addition to the output of the status information, the laser beam is used to display the reading quality. Depending on how many read results could be extracted, the duration of the laser's "off" time increases.</p> <p>If the reading quality is high, the laser beam flashes in brief, regular intervals. The worse the decoder decodes, the longer the pauses become during which the laser is switched off. The flashing intervals become more and more irregular because the laser may, in total, be active for longer to extract more labels. The duration of the pauses has been stepped in such a way that they can be distinguished by the eye.</p>
Parameter	<p>'+' : Starts the adjustment mode. '-' : Ends the adjustment mode.</p>
Acknowledgment	<p>'yyy_zzzzzz' yyy: Reading quality in %. A high process availability is ensured at read qualities > 75%. zzzzzz: Bar code information.</p>

Manual definition of the reference code

Command	RS
Description	This command can be used to define a new reference code in the BCL 348 <i>i</i> by means of direct input via the serial interface. The data is saved in the parameter set according to your input under reference code 1 through 2 and stored in the working buffer for direct further processing.
Parameter	<p>'RSyvxxzzzzzzzz'</p> <p>y, v, x and z are placeholders (variables) for the actual input.</p> <p>y Defined reference code no.</p> <p>'1' (Code 1)</p> <p>'2' (Code 2)</p> <p>v Storage location for reference code:</p> <p>'0' RAM+EEPROM,</p> <p>'3' RAM only</p> <p>xx Defined code type (see command 'CA')</p> <p>z Defined code information (1 ... 63 characters)</p>
Acknowledgment	<p>'RSx'</p> <p>x Status</p> <p>'0' Valid 'Rx' command</p> <p>'1' Invalid command</p> <p>'2' Insufficient memory for reference code</p> <p>'3' Reference code has not been saved</p> <p>'4' Reference code invalid</p>
Example	Input = 'RS130678654331' (Code 1 (1), RAM only (3), UPC (06), code information)

Reference code teach-in

Command	'RT'
Description	This command enables a reference code to be defined quickly by reading an example label.
Parameter	<p>'RTy'</p> <p>y Function</p> <p> '1' Defines reference code 1</p> <p> '2' Defines reference code 2</p> <p> '+' Activates the definition of reference code 1 up to the value of Parameter no_of_labels</p> <p> '.' Exits the Teach-in process</p>
Acknowledgment	<p>The BCL 348<i>i</i> first responds with the command 'RS' and corresponding status (see command 'RS'). After a bar code has been read, it sends the result in the following format:</p> <p>'RCyvxxzzzzz'</p> <p>y, v, x and z are placeholders (variables) for the actual input.</p> <p>y Defined reference code no.</p> <p> '1' (Code 1)</p> <p> '2' (Code 2)</p> <p>v Memory location for reference code</p> <p> '0' RAM+EEPROM,</p> <p> '3' RAM only</p> <p>xx Defined code type (see command 'CA')</p> <p>z Defined code information (1 ... 63 characters)</p>



Notice!

With this function, only code types are recognized that are identified using the autoConfig function or which were set in the setup.

- ↳ After each reading via an 'RTy' command, explicitly switch off the function again since failure to do so will interfere with other commands as well as prevent execution of a new 'RTx' command.

Reading a reference code

Command	'RR'
Description	The command reads out the reference code defined in the BCL 348 <i>i</i> . If no parameters are specified, all defined codes are output.
Parameter	<Reference code number> '1' ... '2' value range of reference codes 1 to 2
Acknowledgment	<p>If no reference codes are defined, the BCL 348<i>i</i> responds with the 'RS' command and corresponding status (see command 'RS'). For valid codes, the output corresponds to the following format:</p> <p>RCyvxxzzzzzz</p> <p>y, v, x and z are placeholders (variables) for the actual input.</p> <p>y Defined reference code no.</p> <p>'1' (Code 1)</p> <p>'2' (Code 2)</p> <p>v Memory location for reference code</p> <p>'0' RAM+EEPROM,</p> <p>'3' RAM only</p> <p>xx Defined code type (see command 'CA')</p> <p>z Defined code information (1 ... 63 characters)</p>

11.1.2 'Online' commands for system control

Activating sensor input

Command	'+'
Description	<p>The command activates decoding. This command is used to activate the reading gate. It remains active until it is deactivated by one of the following criteria:</p> <ul style="list-style-type: none"> • Deactivation by a manual command • Deactivation by a switching input • Deactivation upon reaching the specified read quality (equal scans) • Deactivation by timeout • Deactivation upon reaching a preset number of scans without information.
Parameter	no
Acknowledgment	None

Deactivating sensor input

Command	'-'
Description	<p>The command deactivates decoding. This command can be used to deactivate the reading gate. Following deactivation, the read result is output. Because the reading gate was manually deactivated and, thus, no GoodRead criterion was met, a NoRead is output.</p>
Parameter	no
Acknowledgment	None

11.1.3 'Online' commands for configuration of switching inputs/outputs

Activate switching output

Command	'OA'
Description	The switching outputs 1 and 2 can be activated with this command. The respective port must have been configured as a switching output. The logic state is output, i.e., an inverted logic is taken into account (e.g., inverted logic and a state of High corresponds to a voltage of 0V at the switching output).
Parameter	'OA<a>' <a> Selected switching output [1, 2], unit (dimensionless)
Acknowledgment	None

Query the state of the switching outputs

Command	'OA'
Description	This command may be used to query the states of the switching inputs and outputs that are configured as a switching output and that have been set via commands. The logic state is output, i.e., an inverted logic is taken into account (e.g., inverted logic and a state of High corresponds to a voltage of 0V at the switching output).
Parameter	'OA?'
Acknowledgment	'OA S1=<a>;S2=<a>' <a> State of the switching outputs '0' Low '1' High 'I' Configuration as switching input 'P' Passive configuration

Set the state of the switching outputs

Command	'OA'
Description	This command is used to set the states of the switching inputs/outputs that are configured as a switching output. The logic state is specified, i.e., an inverted logic is taken into account (e.g., inverted logic and a state of High corresponds to a voltage of 0V at the switching output). The values of the switching inputs/outputs that are not configured as switching outputs are ignored. You may also use only a selection of the existing switching inputs/outputs as long as these are listed in ascending order.
Parameter	'OA [S1=<a>][:S2=<a>]' <a> State of the switching output '0' Low '1' High
Acknowledgment	'OA=<aa>' <aa> Status acknowledgment, unit (dimensionless) '00' ok '01' Syntax error '02' Parameter error '03' Other error

Deactivate switching output

Command	'OD'
Description	The switching outputs 1 and 2 can be deactivated with this command. The respective port must have been configured as a switching output. The logic state is output, i.e., an inverted logic is taken into account (e.g., inverted logic and a state of High corresponds to a voltage of 0V at the switching output).
Parameter	'OD<a>' <a> Selected switching output [1, 2], unit (dimensionless)
Acknowledgment	None

Query the configuration of the switching inputs/outputs

Command	'OF'
Description	This command may be used to query the configuration of the switching inputs/outputs 1 and 2.
Parameter	'OF?'
Acknowledgment	'OF S1=<a>;S2=<a>' <a> Function of the switching input/ output, unit [dimensionless] 'I' Switching input 'O' Switching output 'P' Passive

Configure the switching inputs/ outputs

Command	'OF'
Description	This command may be used to configure the function of the switching inputs/outputs 1 and 2. You may also use only a selection of the existing switching inputs/outputs as long as these are listed in ascending order.
Parameter	'OF [S1=<a>];[;S2=<a>]' <a> Function of the switching input/ output, unit [dimensionless] 'I' Switching input 'O' Switching output 'P' Passive
Acknowledgment	'OF=<bb>' <bb> Status acknowledgment '00' ok '01' Syntax error '02' Parameter error '03' Other error

11.1.4 'Online' commands for the parameter set operations

Copying parameter set

Command	'PC'
Description	This command can only be used to copy parameter sets in their entirety. This can be used to replicate the three parameter sets default , permanent and operating parameters on the basis of one another. In addition, this command can also be used to restore the factory settings.
Parameter	<p>'PC<Source type><Target type>' <Source type>Parameter data set which is to be copied, unit [dimensionless] '0' Parameter data set in permanent memory '2' Default or factory parameter set '3' Operating parameter data set in volatile memory <Target type> Parameter set to which the data is to be copied, unit [dimensionless] '0' Parameter data set in permanent memory '3' Operating parameter data set in volatile memory Permissible combinations here include: '03' Copying the data set from the permanent memory to the operating parameter data set '30' Copying the operating parameter data set to the permanent parameter set memory '20' Copying the default parameters to the permanent memory and to the main memory</p>
Acknowledgment	<p>'PS=<aa>' <aa> Status acknowledgment, unit [dimensionless] '00' Ok '01' Syntax error '02' Impermissible command length '03' Reserved '04' Reserved '05' Reserved '06' Impermissible combination, source type - target type</p>

Requesting parameter data set from BCL 348*i*

Determining parameter set difference to default parameters

Command	'PR'
Description	The parameters of the BCL 348 <i>i</i> are grouped together in a parameter set and permanently stored in memory. There is one parameter set in permanent memory and one operating parameter set in volatile memory; in addition, there is a default parameter set (factory parameter set) for initialization. This command can be used to edit the first two parameter sets (in permanent and volatile memory). A check sum can be used for reliable parameter transfer.
Parameter	<p>'PR<BCC type><PS type><Address><Data length>[<BCC>]'</p> <p><BCC type> Check-digit function during transfer, unit [dimensionless]</p> <p>'0' Not used</p> <p>'3' BCC mode 3</p> <p><PS type> Memory from which the values are to be read, unit [dimensionless]</p> <p>'0' Parameter values stored in the flash memory</p> <p>'1' Reserved</p> <p>'2' Default values</p> <p>'3' Operating values in RAM</p> <p><Address> Relative address of the data within the data set</p> <p>'aaaa' Four-digit, unit [dimensionless]</p> <p><Data length> Length of the parameter data to be transferred</p> <p>'bbbb' Four-digit, unit [length in bytes]</p> <p><BCC> Check sum calculated as specified under BCC type</p>

Command	'PR'
<p>Acknowledgment positive</p>	<p>PT<BCC type><PS type><Status><Start> <Address parameter value><Address+1 parameter value>... [:<Address><Address parameter value>][<BCC>] <BCC type> Check-digit function during transfer, unit [dimensionless] '0' Not used '3' BCC mode 3 <PS type> Memory from which the values are to be read, unit [dimensionless] '0' Parameter values stored in the flash memory '2' Default values '3' Operating values in RAM <Status> Mode of parameter processing, unit [dimensionless] '0' No further parameters '1' Additional parameters follow <Start> Relative address of the data within the data set, 'aaaa' Four-digit, unit [dimensionless] <P.value A.>Parameter value of the parameter stored at this address; the parameter set data 'bb' is converted from HEX format to a 2-byte ASCII-format for transfer. <BCC> Check sum calculated as specified under BCC type</p>
<p>Acknowledgment negative</p>	<p>'PS=<aa>' Parameter reply: <aa> Status acknowledgment, unit [dimensionless] '01' Syntax error '02' Impermissible command length '03' Impermissible value for checksum type '04' Invalid check sum received '05' Impermissible number of data requested '06' Requested data does not (any longer) fit in the transmission buffer '07' Impermissible address value '08' Read access after end of data set '09' Impermissible QPF data set type</p>

Command	'PD'
<p>Description</p>	<p>This command outputs the difference between the default parameter set and the operating parameter set or the difference between the default parameter set and the permanent parameter set.</p> <p>Comment: The reply supplied by this command can e.g. be directly used for programming a device with factory settings, whereby this device receives the same configuration as the device on which the PD-sequence was executed.</p>
<p>Parameter</p>	<p>'PD<P.set1><P.set2>' <P.set1> Parameter data set which is to be copied, unit [dimensionless] '0' Parameter data set in permanent memory '2' Default or factory parameter set <P.set2> Parameter set to which the data is to be copied, unit [dimensionless] '0' Parameter data set in permanent memory '3' Operating parameter data set in volatile memory Permissible combinations here include: '20' Output of the parameter differences between the default and the permanently saved parameter set '23' Output of the parameter differences between the default parameter set and the operating parameter set saved in volatile memory '03' Output of the parameter differences between the permanent parameter set and the operating parameter set saved in volatile memory</p>
<p>Acknowledgment positive</p>	<p>PT<BCC><PS type><Status><Adr.><P.value adr.><P.valueAdr.+1>... [;<Adr.><P.value adr.>] <BCC> '0' No check digit '3' BCC mode 3 <PS type> '0' Values stored in flash memory '3' Operating values stored in RAM <Status> '0' No further parameters '1' Additional parameters follow <Adr.> Relative address of the data within the data set 'aaaa' Four-digit, unit [dimensionless] <P.value> Parameter value of the -bb- parameter stored at this address. The parameter set data is converted from HEX format to a 2-byte-ASCII format for transfer.</p>

Command	'PD'
Acknowledgment negative	'PS=<aa>'
	<aa>
	Status acknowledgment, unit [dimensionless]
	'0'
	No difference
	'1'
Syntax error	
'2'	
Impermissible command length	
'6'	
Impermissible combination, parameter set 1 and parameter set 2	
'8'	
Invalid parameter set	

Writing parameter set

Command	'PT'
Description	<p>The parameters of the BCL 348<i>i</i> are grouped together in a parameter set and permanently stored in memory. There is one parameter set in permanent memory and one operating parameter set in volatile memory; in addition, there is a default parameter set (factory parameter set) for initialization. This command can be used to edit the first two parameter sets (in permanent and volatile memory). A check sum can be used for reliable parameter transfer.</p>
Parameter	<p>PT<BCC type><PS type><Status><Adr.><P.value adr.><P.value adr+1>...[:<Adr.><P.value adr.>][<BCC>]</p> <p><BCC type> Check-digit function during transfer, unit [dimensionless]</p> <p>'0' No check digit</p> <p>'3' BCC mode 3</p> <p><PS type> Memory from which the values are to be read, unit [dimensionless]</p> <p>'0' Parameter values stored in the flash memory</p> <p>'3' Operating values stored in RAM</p> <p><Status> Mode of parameter processing, without function here, unit [dimensionless]</p> <p>'0' No reset after parameter change, no further parameters</p> <p>'1' No reset after parameter change, additional parameters follow</p> <p>'2' With reset after parameter change, no further parameters</p> <p>'6' Set parameters to factory setting, no further parameters</p> <p>'7' Set parameters to factory settings, lock all code types; the code-type setting must follow in the command!</p> <p><Adr.> Relative address of the data within the data set, 'aaaa' Four-digit, unit [dimensionless]</p> <p><P.value> Parameter value of the -bb- parameter stored at this address. The parameter set data is converted from HEX format to a 2-byte-ASCII format for transfer.</p> <p><BCC> Check sum calculated as specified under BCC type</p>

Command	'PT'
Acknowledgment	'PS=<aa>'
	Parameter reply:
	<aa> Status acknowledgment, unit [dimensionless]
	'01' Syntax error
	'02' Impermissible command length
	'03' Impermissible value for checksum type
	'04' Invalid check sum received
	'05' Impermissible data length
	'06' Invalid data (parameter limits violated)
	'07' Invalid start address
'08' Invalid parameter set	
'09' Invalid parameter set type	

12 Diagnostics and troubleshooting

For the PROFINET-IO, there are two different options for diagnosis.

Event-related diagnostics

PROFINET-IO transmits events within an automation process as alarms that must be acknowledged by the application process.

The following events are possible:

- Process alarms: Events that originate from the process and are reported to the control.
- Diagnostic alarms: Events that indicate the malfunctioning of an IO device.
- Maintenance alarms: Transmission of information to avoid the failure of a device through preventative maintenance work.
- Manufacturer-specific diagnostics

To identify the alarms uniquely, they are always reported via a slot/subslot. The user can prioritize diagnostic and process alarms differently.

12.1 General causes of errors

Error	Possible error cause	Measures
Status LED PWR		
Off	<ul style="list-style-type: none"> • No supply voltage connected to the device • Hardware error 	<input type="checkbox"/> Check supply voltage <input type="checkbox"/> Send device to customer service
Red, flashing	<ul style="list-style-type: none"> • Warning 	<input type="checkbox"/> Query diagnostic data and carry out the resulting measures
Red, continuous light	<ul style="list-style-type: none"> • Error: no function possible 	<input type="checkbox"/> Internal device error, send in device
Orange, continuous light	<ul style="list-style-type: none"> • Device in service mode 	<input type="checkbox"/> Reset service mode with webConfig tool
Status LED BUS		
Off	<ul style="list-style-type: none"> • No supply voltage connected to the device • Device not yet recognized by the PROFINET-IO • Hardware error 	<input type="checkbox"/> Check supply voltage <input type="checkbox"/> Send device to customer service <input type="checkbox"/> Send device to customer service
Red, flashing	<ul style="list-style-type: none"> • Communication error: Parameterization or configuration failed, IO error: No data exchange 	<input type="checkbox"/> Check interface <input type="checkbox"/> Can be corrected by resetting
Red, continuous light	<ul style="list-style-type: none"> • Communication error on the PROFINET-IO: No communication to IO Controller established ("no data exchange") 	<input type="checkbox"/> Check interface <input type="checkbox"/> Check wiring <input type="checkbox"/> Cannot be corrected by resetting <input type="checkbox"/> Send device to customer service

Table 12.1: General causes of errors

12.2 Interface errors

Error	Possible error cause	Measures
No communication via USB service interface	<ul style="list-style-type: none"> • Incorrect connection cable • Connected BCL 348<i>i</i> is not detected 	<input type="checkbox"/> Check connection cable <input type="checkbox"/> Install USB driver
No communication via PROFINET-IO BUS status LED continuous red light	<ul style="list-style-type: none"> • Incorrect wiring • Different protocol settings • Protocol not released • Wrong termination • Incorrect device name set • Incorrect configuration 	<input type="checkbox"/> Check wiring <input type="checkbox"/> Check protocol settings <input type="checkbox"/> Activate TCP/ IP or UDP <input type="checkbox"/> Check termination <input type="checkbox"/> Check device name <input type="checkbox"/> Check configuration of the device in the configuration tool
Sporadic errors at the PROFINET-IO	<ul style="list-style-type: none"> • Incorrect wiring • Effects due to EMC • Overall network expansion exceeded 	<input type="checkbox"/> Check wiring <ul style="list-style-type: none"> • In particular, check wire shielding • Check the cable used <input type="checkbox"/> Check shielding (shield covering in place up to the clamping point) <input type="checkbox"/> Check grounding concept and connection to functional earth (FE) <input type="checkbox"/> Avoid EMC coupling caused by power cables laid parallel to device lines. <input type="checkbox"/> Check max. network expansion as a function of the max. cable lengths

Table 12.2: Interface error



Notice!

Please use **chapter 12 as a master copy** should servicing be required.

Cross the items in the "Measures" column which you have already examined, fill out the following address field and fax the pages together with your service contract to the fax number listed below.

Customer data (please complete)

Device type:	
Company:	
Contact partner / department:	
Phone (direct):	
Fax:	
Street / No:	
ZIP code/City:	
Country:	

Leuze Service fax number:
+49 7021 573 - 199

13 Type overview and accessories

13.1 Part number code

BCL 300i OM100D H	
Heating option	H = With heating
Display option	D = With display and two control button
Beam exit	0 Lateral
	2 Front
Optics	N High Density (near)
	M Medium Density (medium distance)
	F Low Density (remote)
	L Long Range (very large distances)
Scanning principle	S Line scanner (single line)
	R1 Line scanner (raster)
	O Oscillating-mirror scanner
Interface	<i>i</i> = Integrated fieldbus technology
	00 RS 232/RS 422 (standalone)
	01 RS 485 (multiNet Slave)
	04 PROFIBUS DP
	08 ETHERNET TCP/IP, UDP
	48 PROFINET-IO RT
	BCL Bar code reader

Table 13.1: Part number code BCL 348*i*

13.2 Type overview BCL 348*i*

PROFINET-IO participant with 2x PROFINET-IO:

Type designation	Description	Part no.
Single line scanner with frontal beam exit		
BCL 348 <i>i</i> S N 102	with N optics	50116462
BCL 348 <i>i</i> S M 102	with M optics	50116456
BCL 348 <i>i</i> S F 102	with F optics	50116444
BCL 348 <i>i</i> S L 102	with L optics	50116450
BCL 348 <i>i</i> S N 102 D	with N optics and display	50116461
BCL 348 <i>i</i> S M 102 D	with M optics and display	50116455
BCL 348 <i>i</i> S F 102 D	with F optics and display	50116443
BCL 348 <i>i</i> S L 102 D	with L optics and display	50116449
BCL 348 <i>i</i> S N 102 D H	with N optics, display and heating	50116460
BCL 348 <i>i</i> S M 102 D H	with M optics, display and heating	50116454
BCL 348 <i>i</i> S F 102 D H	with F optics, display and heating	50116442
BCL 348 <i>i</i> S L 102 D H	with L optics, display and heating	50116448
Raster scanner with frontal beam exit		
BCL 348 <i>i</i> R1 N 102	with N optics	50116438
BCL 348 <i>i</i> R1 M 102	with M optics	50116434
BCL 348 <i>i</i> R1 F 102	with F optics	50116430
BCL 348 <i>i</i> R1 N 102 D	with N optics and display	50116437
BCL 348 <i>i</i> R1 M 102 D	with M optics and display	50116433
BCL 348 <i>i</i> R1 F 102 D	with F optics and display	50116429
Single line scanner with deflection mirror		
BCL 348 <i>i</i> S N 100	with N optics	50116459
BCL 348 <i>i</i> S M 100	with M optics	50116451
BCL 348 <i>i</i> S F 100	with F optics	50116441
BCL 348 <i>i</i> S L 100	with L optics	50116447
BCL 348 <i>i</i> S N 100 D	with N optics and display	50116458
BCL 348 <i>i</i> S M 100 D	with M optics and display	50116453
BCL 348 <i>i</i> S F 100 D	with F optics and display	50116440
BCL 348 <i>i</i> S L 100 D	with L optics and display	50116446
BCL 348 <i>i</i> S N 100 D H	with N optics, display and heating	50116457
BCL 348 <i>i</i> S M 100 D H	with M optics, display and heating	50116452
BCL 348 <i>i</i> S F 100 D H	with F optics, display and heating	50116439
BCL 348 <i>i</i> S L 100 D H	with L optics, display and heating	50116445
Raster scanner with deflection mirror		
BCL 348 <i>i</i> R1 N 100	with N optics	50116436
BCL 348 <i>i</i> R1 M 100	with M optics	50116432
BCL 348 <i>i</i> R1 F 100	with F optics	50116428
BCL 348 <i>i</i> R1 N 100 D	with N optics and display	50116435
BCL 348 <i>i</i> R1 M 100 D	with M optics and display	50116431
BCL 348 <i>i</i> R1 F 100 D	with F optics and display	50116427
Oscillating mirror scanner		
BCL 348 <i>i</i> O N 100	with N optics	50116424
BCL 348 <i>i</i> O M 100	with M optics	50116421
BCL 348 <i>i</i> O F 100	with F optics	50116415
BCL 348 <i>i</i> O L 100	with L optics	50116418
BCL 348 <i>i</i> O N 100 D	with N optics and display	50116425
BCL 348 <i>i</i> O M 100 D	with M optics and display	50116422
BCL 348 <i>i</i> O F 100 D	with F optics and display	50116416
BCL 348 <i>i</i> O L 100 D	with L optics and display	50116419
BCL 348 <i>i</i> O N 100 D H	with N optics, display and heating	50116426
BCL 348 <i>i</i> O M 100 D H	with M optics, display and heating	50116423
BCL 348 <i>i</i> O F 100 D H	with F optics, display and heating	50116417
BCL 348 <i>i</i> O L 100 D H	with L optics, display and heating	50116420

13.3 Connection hood accessories

Type designation	Description	Part no.
MS 348	Hood with integrated connectors for BCL 348 <i>i</i>	50116471
MK 348	Terminal hood for BCL 348 <i>i</i>	50116467

Table 13.2: Connection hoods for the BCL 348*i*

13.4 Accessory connectors

Type designation	Description	Part no.
KD 095-5A	M12 axial socket for voltage supply, shielded	50020501
D-ET1	RJ45 connector for user-configuration	50108991
S-M12A-ET	Axial M12 connector, D-coded, for self-assembly	50106119
KDS ET M12 / RJ 45 W - 4P	Converter from M12 D-coded to RJ 45 socket	50109832

Table 13.3: Connectors for the BCL 348*i*

13.5 Accessory USB cable

Type designation	Description	Part no.
KB USBA-USBminiB	USB service cable, 2 type A and Mini-B type connectors, length 1m	50117011

Table 13.4: Service cable for the BCL 348*i*

13.6 Accessory mounting device

Type designation	Description	Part no.
BT 56	Mounting device for rod	50027375
BT 59	Mounting device for ITEM	50111224

Table 13.5: Mounting devices for the BCL 348*i*

13.7 Reflector accessories for autoRefIAct

Type designation	Description	Part no.
Reflective tape no. 4 / 100 x 100 mm	Reflective tape as reflector for autoRefIAct operation	50106119

Table 13.6: Reflector for autoRefIAct operation

13.8 Accessory ready-made cables for voltage supply

13.8.1 Contact assignment of PWR connection cable

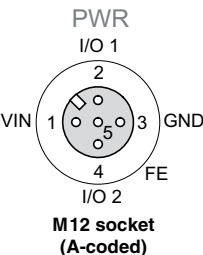
PWR connection cable (5-pin socket, A-coded, not shielded)			
	Pin	Name	Core color
	1	VIN	brown
	2	I/O 1	white
	3	GND	blue
	4	I/O 2	black
	5	FE	gray
Thread	FE	bare	



Notice!

These cables are not shielded.

13.8.2 Specifications of the cables for voltage supply

Operating temperature range	in rest state:	-30°C ... +70°C
	in motion:	5°C ... +70°C
Material	sheathing:	PVC
Bending radius		> 50mm

13.8.3 Order codes of the cables for voltage supply

Type designation	Description	Part no.
K-D M12A-5P-5m-PVC	M12 socket for PWR, axial connector, open cable end, cable length 5m, not shielded	50104557
K-D M12A-5P-10m-PVC	M12 socket for PWR, axial plug outlet, open cable end, cable length 10m, not shielded	50104559

Table 13.7: PWR cables for the BCL 348*i*

13.9 Accessory ready-made cables for bus connection

13.9.1 General information

- Cable **KB ET...** for connecting to PROFINET-IO via M12 connector
- Standard cable available in lengths from 2 ... 30m
- Special cables on request.

13.9.2 Contact assignments M12 PROFINET-IO connection cable KB ET...

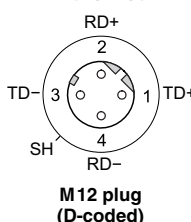
M12 PROFINET-IO connection cable (4-pin connector, D-coded, on both sides)			
 <p>Ethernet</p> <p>RD+</p> <p>2</p> <p>TD-</p> <p>3</p> <p>1</p> <p>TD+</p> <p>4</p> <p>RD-</p> <p>SH</p> <p>M12 plug (D-coded)</p>	Pin	Name	Core color
	1	TD+	yellow
	2	RD+	white
	3	TD-	orange
	4	RD-	blue
SH (thread)	FE	bare	



Core colors	
	WH
	YE
	BU
	OG
Conductor class: VDE 0295, EN 60228, IEC 60228 (Class 5)	
	Shielding contact via connector housing!

Figure 13.8: Cable configuration PROFINET-IO connection cable

13.9.3 Specifications M12 PROFINET-IO connection cable KB ET...

Operating temperature range	in rest state: -50°C ... +80°C in motion: -25°C ... +80°C in motion: -25°C ... +60°C (when used with drag chains)
Material	cable sheath: PUR (green), wire insulation: PE foam, free of halogens, silicone and PVC
Bending radius	> 65mm, suitable for drag chains
Bending cycles	> 10 ⁶ , perm. acceleration < 5 m/s ²

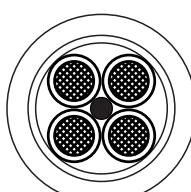
13.9.4 Order codes M12 PROFINET-IO connection cable KB ET...

Type designation	Description	Part no.
M12 plug for BUS IN, axial connector, open cable end		
KB ET - 1000 - SA	Cable length 1m	50106738
KB ET - 2000 - SA	Cable length 2m	50106739
KB ET - 5000 - SA	Cable length 5m	50106740
KB ET - 10000 - SA	Cable length 10m	50106741
KB ET - 15000 - SA	Cable length 15m	50106742
KB ET - 20000 - SA	Cable length 20m	50106743
KB ET - 25000 - SA	Cable length 25m	50106745
KB ET - 30000 - SA	Cable length 30m	50106746
M12 plug for BUS IN to RJ-45 connector		
KB ET - 1000 - SA-RJ45	Cable length 1m	50109879
KB ET - 2000 - SA-RJ45	Cable length 2m	50109880
KB ET - 5000 - SA-RJ45	Cable length 5m	50109881
KB ET - 10000 - SA-RJ45	Cable length 10m	50109882
KB ET - 15000 - SA-RJ45	Cable length 15m	50109883
KB ET - 20000 - SA-RJ45	Cable length 20m	50109884
KB ET - 25000 - SA-RJ45	Cable length 25m	50109885
KB ET - 30000 - SA-RJ45	Cable length 30m	50109886
M12 plug + M12 plug for BUS OUT to BUS IN		
KB ET - 1000 - SSA	Cable length 1m	50106898
KB ET - 2000 - SSA	Cable length 2m	50106899
KB ET - 5000 - SSA	Cable length 5m	50106900
KB ET - 10000 - SSA	Cable length 10m	50106901
KB ET - 15000 - SSA	Cable length 15m	50106902
KB ET - 20000 - SSA	Cable length 20m	50106903
KB ET - 25000 - SSA	Cable length 25m	50106904
KB ET - 30000 - SSA	Cable length 30m	50106905

Table 13.9: Bus connection cable for the BCL 348*i*

14 Maintenance

14.1 General maintenance information

Usually, the bar code reader BCL 348*i* does not require any maintenance by the operator.

Cleaning

Clean glass surface with a damp sponge soaked in commercial cleaning detergent. Then rub it with a soft, clean, dry cloth.



Notice!

Do not use aggressive cleaning agents such as thinner or acetone for cleaning the device. Use of improper cleaning agents can damage the housing window.

14.2 Repairs, servicing

Repairs to the device must only be carried out by the manufacturer.

 *Contact your Leuze distributor or service organization should repairs be required. The addresses can be found on the inside of the cover and on the back.*



Notice!

When sending devices to Leuze electronic for repair, please provide an accurate description of the error.

14.3 Disassembling, packing, disposing

Repacking

For later reuse, the device is to be packed so that it is protected.



Notice!

Electrical scrap is a special waste product! Observe the locally applicable regulations regarding disposal of the product.

15 Appendix

15.1 Declaration of Conformity

 the <i>sensor</i> people		
EG-KONFORMITÄTS- ERKLÄRUNG	EC DECLARATION OF CONFORMITY	DECLARATION CE DE CONFORMITE
Der Hersteller	The Manufacturer	Le constructeur
	Leuze electronic GmbH + Co. KG In der Braiko 1, PO Box 1111 73277 Owen, Germany	
erklärt, dass die nachfolgend aufgeführten Produkte den einschlägigen Anforderungen der genannten EG-Richtlinien entsprechen.	declares that the following listed products fulfil the relevant provisions of the mentioned EC Directives.	déclare que les produits identifiés suivants sont conformes aux directives CE mentionnées.
Produktbeschreibung:	Description of product:	Description de produit:
Stationärer Barcodeleser BCL 3xxl	Stationary Barcode Reader BCL 3xxl	Lecteurs Stationn. de Code à Barres BCL 3xxl
Angewandte EG-Richtlinie(n):	Applied EC Directive(s):	Directive(s) CE appliquées:
2004/108/EG 2006/95/EG	2004/108/EC 2006/95/EC	2004/108/CE 2006/95/CE
Angewandte Normen:	Applied standards:	Normes appliquées:
EN 61000-6-2: 2005 EN 60825-1: 2007		EN 61000-6-3: 2007
<div style="display: flex; justify-content: space-between; align-items: center;"> <div style="text-align: center;"> <p style="font-size: 1.2em; color: blue;">24.8.2011</p> <p>Datum / Date / Date</p> </div> <div style="text-align: center;">  <p>Dr. Harald Grubel, Geschäftsführer / Director / Directeur</p> </div> </div>		
Leuze electronic GmbH + Co. KG In der Braiko 1 D-73277 Owen Telefon +49 (0) 7021 573-0 Telefax +49 (0) 7021 573-159 info@leuze.de www.leuze.com LEO-ZQM-148-01-FO	Leuze electronic GmbH + Co. KG, Sitz: Owen, Registergericht Stuttgart, HRB 230712 Persönlich haftende Gesellschafterin Leuze electronic Geschäftsbühninge-GmbH, Sitz: Owen, Registergericht Stuttgart, HRB 230550 Geschäftsführer: Dr. Harald Grubel (Vorsitzender), Karsten Just USt-IdNr. DE 145912621 Zollnummer 2554232 Es gelten ausschließlich unsere aktuellen Verkaufs- und Lieferbedingungen Only our current Terms and Conditions of Sale and Delivery shall apply.	

Figure 15.1: Declaration of conformity BCL 348*i*

 the <i>sensor</i> people		
EG-KONFORMITÄTS- ERKLÄRUNG	EC DECLARATION OF CONFORMITY	DECLARATION CE DE CONFORMITE
Der Hersteller	The Manufacturer	Le constructeur
	Leuze electronic GmbH + Co. KG In der Braike 1, PO Box 1111 73277 Owen, Germany	
erklärt, dass die nachfolgend aufgeführten Produkte den einschlägigen Anforderungen der genannten EG-Richtlinien entsprechen.	declares that the following listed products fulfil the relevant provisions of the mentioned EC Directives.	déclare que les produits identifiés suivants sont conformes aux directives CE mentionnées.
Produktbeschreibung:	Description of product:	Description de produit:
Modulare Steckerhaube MS 3xx, Modulare Klemmhaube MK 3xx, Modulare Anschlusseinheit MA 100	Modular hood with integrated connectors MS 3xx, Modular terminal hoods MK 3xx, Modular interfacing unit MA 100	Logement modulaire de prises MS 3xx, Logement modulaire de bornes MK 3xx, Unité modulaire de branchement MA 100
Angewandte EG-Richtlinie(n):	Applied EC Directive(s):	Directive(s) CE appliquées:
2004/108/EG	2004/108/EC	2004/108/CE
Angewandte Normen:	Applied standards:	Normes appliquées:
EN 61000-6-2: 2005		EN 61000-6-4: 2007
<div style="display: flex; justify-content: space-around; align-items: center;"> <div style="text-align: center;">  Datum / Date / Date </div> <div style="text-align: center;">  Dr. Harald Gruber, Geschäftsführer / Director / Directeur </div> </div>		
Leuze electronic GmbH + Co. KG In der Braike 1 D-73277 Owen Telefon +49 (0) 7021 573-0 Telefax +49 (0) 7021 573-199 info@leuze.de www.leuze.com LEO-ZQM-148-01-FO	Leuze electronic GmbH + Co. KG, Sitz Owen, Registergericht Stuttgart, HRA 230712 Persönlich haftende Gesellschafterin Leuze electronic Geschäftsführungs-GmbH, Sitz Owen, Registergericht Stuttgart, HRB 230050 Geschäftsführer: Dr. Harald Gruber (Vorsitzender), Karsten Just USt-IdNr. DE 44312521 Zulassnummer 2554252 Es gelten ausschließlich unsere aktuellen Verkaufs- und Lieferbedingungen Only our current Terms and Conditions of Sale and Delivery shall apply	

Figure 15.2: Connection hood / connector unit declaration of conformity

15.2 ASCII character set

ASCII	Dec.	Hex.	Oct.	Designation	Meaning
NUL	0	00	0	NULL	Zero
SOH	1	01	1	START OF HEADING	Start of heading
STX	2	02	2	START OF TEXT	Start of text characters
ETX	3	03	3	END OF TEXT	Last character of text
EOT	4	04	4	END OF TRANSMISS.	End of transmission
ENQ	5	05	5	ENQUIRY	Request for data trans.
ACK	6	06	6	ACKNOWLEDGE	Positive acknowledgment
BEL	7	07	7	BELL	Bell signal
BS	8	08	10	BACKSPACE	Backspace
HT	9	09	11	HORIZ. TABULATOR	Horizontal tabulator
LF	10	0A	12	LINE FEED	Line feed
VT	11	0B	13	VERT. TABULATOR	Vertical tabulator
FF	12	0C	14	FORM FEED	Form feed
CR	13	0D	15	CARRIAGE RETURN	Carriage return
SO	14	0E	16	SHIFT OUT	Shift out
SI	15	0F	17	SHIFT IN	Shift in
DLE	16	10	20	DATA LINK ESCAPE	Data link escape
DC1	17	11	21	DEVICE CONTROL 1	Device control character 1
DC2	18	12	22	DEVICE CONTROL 2	Device control character 2
DC3	19	13	23	DEVICE CONTROL 3	Device control character 3
DC4	20	14	24	DEVICE CONTROL 4	Device control character 4
NAK	21	15	25	NEG. ACKNOWLEDGE	Negative acknowledge
SYN	22	16	26	SYNCHRONOUS IDLE	Synchronization
ETB	23	17	27	EOF TRANSM. BLOCK	End of data transmission block
CAN	24	18	30	CANCEL	Invalid
EM	25	19	31	END OF MEDIUM	End of medium
SUB	26	1A	32	SUBSTITUTE	Substitution
ESC	27	1B	33	ESCAPE	Escape
FS	28	1C	34	FILE SEPARATOR	File separator
GS	29	1D	35	GROUP SEPARATOR	Group separator
RS	30	1E	36	RECORD SEPARATOR	Record separator
US	31	1F	37	UNIT SEPARATOR	Unit separator
SP	32	20	40	SPACE	Space
!	33	21	41	EXCLAMATION POINT	Exclamation point

ASCII	Dec.	Hex.	Oct.	Designation	Meaning
"	34	22	42	QUOTATION MARK	Quotation mark
#	35	23	43	NUMBER SIGN	Number sign
\$	36	24	44	DOLLAR SIGN	Dollar sign
%	37	25	45	PERCENT SIGN	Percent sign
&	38	26	46	AMPERSAND	Ampersand
'	39	27	47	APOSTROPHE	Apostrophe
(40	28	50	OPEN. PARENTHESIS	Open parenthesis
)	41	29	51	CLOS. PARENTHESIS	Closed parenthesis
*	42	2A	52	ASTERISK	Asterisk
+	43	2B	53	PLUS	Plus sign
,	44	2C	54	COMMA	Comma
-	45	2D	55	HYPHEN (MINUS)	Hyphen
.	46	2E	56	PERIOD (DECIMAL)	Period (decimal)
/	47	2F	57	SLANT	Slant
0	48	30	60	0	Number
1	49	31	61	1	Number
2	50	32	62	2	Number
3	51	33	63	3	Number
4	52	34	64	4	Number
5	53	35	65	5	Number
6	54	36	66	6	Number
7	55	37	67	7	Number
8	56	38	70	8	Number
9	57	39	71	9	Number
:	58	3A	72	COLON	Colon
;	59	3B	73	SEMICOLON	Semicolon
<	60	3C	74	LESS THAN	Less than
=	61	3D	75	EQUALS	Equals
>	62	3E	76	GREATER THAN	Greater than
?	63	3F	77	QUESTION MARK	Question mark
@	64	40	100	COMMERCIAL AT	Commercial AT
A	65	41	101	A	Capital letter
B	66	42	102	B	Capital letter
C	67	43	103	C	Capital letter
D	68	44	104	D	Capital letter

ASCII	Dec.	Hex.	Oct.	Designation	Meaning
E	69	45	105	E	Capital letter
F	70	46	106	F	Capital letter
G	71	47	107	G	Capital letter
H	72	48	110	H	Capital letter
I	73	49	111	I	Capital letter
J	74	4A	112	J	Capital letter
K	75	4B	113	K	Capital letter
L	76	4C	114	L	Capital letter
M	77	4D	115	M	Capital letter
N	78	4E	116	N	Capital letter
O	79	4F	117	O	Capital letter
P	80	50	120	P	Capital letter
Q	81	51	121	Q	Capital letter
R	82	52	122	R	Capital letter
S	83	53	123	S	Capital letter
T	84	54	124	T	Capital letter
U	85	55	125	U	Capital letter
V	86	56	126	V	Capital letter
W	87	57	127	W	Capital letter
X	88	58	130	X	Capital letter
Y	89	59	131	Y	Capital letter
Z	90	5A	132	Z	Capital letter
[91	5B	133	OPENING BRACKET	Opening bracket
\	92	5C	134	REVERSE SLANT	Reverse slant
]	93	5D	135	CLOSING BRACKET	Closing bracket
^	94	5E	136	CIRCUMFLEX	Circumflex
_	95	5F	137	UNDERSCORE	Underscore
`	96	60	140	GRAVE ACCENT	Grave accent
a	97	61	141	a	Lower case letter
b	98	62	142	b	Lower case letter
c	99	63	143	c	Lower case letter
d	100	64	144	d	Lower case letter
e	101	65	145	e	Lower case letter
f	102	66	146	f	Lower case letter
g	103	67	147	g	Lower case letter

ASCII	Dec.	Hex.	Oct.	Designation	Meaning
h	104	68	150	h	Lower case letter
i	105	69	151	i	Lower case letter
j	106	6A	152	j	Lower case letter
k	107	6B	153	k	Lower case letter
l	108	6C	154	l	Lower case letter
m	109	6D	155	m	Lower case letter
n	110	6E	156	n	Lower case letter
o	111	6F	157	o	Lower case letter
p	112	70	160	p	Lower case letter
q	113	71	161	q	Lower case letter
r	114	72	162	r	Lower case letter
s	115	73	163	s	Lower case letter
t	116	74	164	t	Lower case letter
u	117	75	165	u	Lower case letter
v	118	76	166	v	Lower case letter
w	119	77	167	w	Lower case letter
x	120	78	170	x	Lower case letter
y	121	79	171	y	Lower case letter
z	122	7A	172	z	Lower case letter
{	123	7B	173	OPENING BRACE	Opening brace
	124	7C	174	VERTICAL LINE	Vertical line
}	125	7D	175	CLOSING BRACE	Closing brace
~	126	7E	176	TILDE	Tilde
DEL	127	7F	177	DELETE (RUBOUT)	Delete

15.3 Bar code samples

15.3.1 Module 0.3

Code type 01: Interleaved 2 of 5

Modul 0,3



1122334455

Code type 02: Code 39

Modul 0,3



135AC

Code type 11: Codabar

Modul 0,3

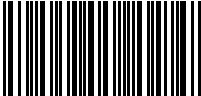

A121314A

Code 128

Modul 0,3



abcde

Code type 08: EAN 128

Modul 0,3



leuze

Code type 06: UPC-A

SC 2

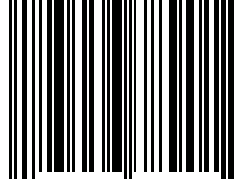

1 23456 78901 2

Code type 07: EAN 8

SC 3

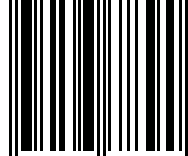

3456 7890

Code type 10: EAN 13 Add-on

SC 0

S



1 122334 455666 77889

Code type 13: GS1 DataBar OMNIDIRECTIONAL



(01) 0 0000123 45678 4

Figure 15.3: Bar code sample labels (module 0.3)

15.3.2 Module 0.5

Code type 01: Interleaved 2 of 5

Modul 0,5



Code type 02: Code 39

Modul 0,5



Code type 11: Codabar

Modul 0,5



Code 128

Modul 0,5



Code type 08: EAN 128

Modul 0,5



Code type 06: UPC-A

SC 4



Code type 07: EAN 8

SC 6



Code type 10: EAN 13 Add-on

SC 2



Figure 15.4: Bar code sample labels (module 0.5)